

**A FIELD BOOK  
GREAT MOUNTAIN FOREST**

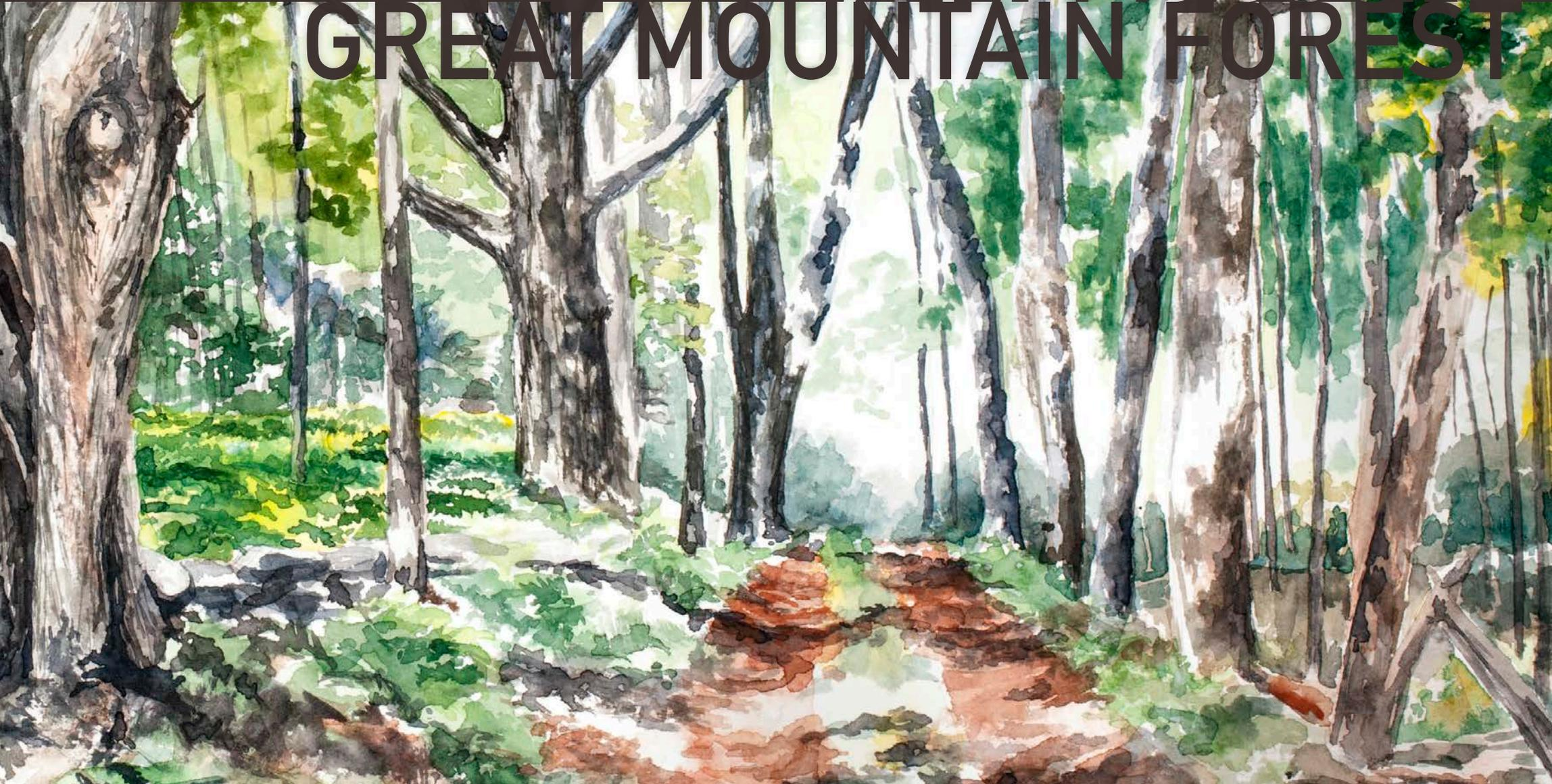



**A FIELD BOOK**  
**GREAT MOUNTAIN FOREST**

MICHAEL GAIGE | YONATAN GLOGOWER

Text by Michael Gaige and Yonatan Glogower

Photographs by Michael Gaige, Yonatan Glogower, and GMF

Watercolors and Design by Autumn Von Plinsky

Copyright © Yale Global Institute of Sustainable Forestry, 2016

All Rights Reserved

# TABLE OF CONTENTS

FOREWORD I.....	i	Eastern White Pine ( <i>Pinus strobus</i> ).....	44
FOREWORD II.....	iii	Maples ( <i>Acer</i> spp.).....	47
INTRODUCTION .....	1	American Beech ( <i>Fagus grandifolia</i> ).....	48
GEOLOGIC UNDERPINNINGS .....	5	Hickories ( <i>Carya</i> spp.) .....	49
DEVELOPMENT OF THE EASTERN DECIDUOUS FOREST ...	11	Hay-Scented Fern ( <i>Dennstaedtia punctilobula</i> ) .....	50
HUMAN HISTORY .....	19	Eastern Newt ( <i>Notophthalmus viridescens</i> ) .....	50
Connecticut's Native Peoples .....	19	Moose ( <i>Alces alces</i> ).....	51
The Settlement of Litchfield County.....	23	White-tailed Deer ( <i>Odocoileus virginianus</i> ).....	52
History of Great Mountain Forest .....	27	Black Bear ( <i>Ursus americanus</i> ) .....	53
SPECIES OF INTEREST .....	37	American Beaver ( <i>Castor canadensis</i> ) .....	53
Eastern Hemlock ( <i>Tsuga canadensis</i> ).....	37	Wild Turkey ( <i>Meleagris gallopavo</i> ) .....	55
American Chestnut ( <i>Castanea dentata</i> ) .....	39	FIELD MARKS.....	57
Mountain Laurel ( <i>Kalmia latifolia</i> ).....	40	Coppiced Trees .....	57
Red Spruce ( <i>Picea rubens</i> ).....	41	Legacy Tree .....	57
Japanese Barberry ( <i>Berberis thunbergii</i> ) .....	41	Old Trees .....	58
Oaks ( <i>Quercus</i> spp.) .....	42	Old Field White Pine.....	59
		Plantations .....	60
		Girdled Pine.....	61
		Early Successional Stands.....	61
		Stone Walls.....	61
		Cellar Holes .....	62
		Clearance Cairns .....	62
		Charcoal Hearths.....	63

Collier Fireplaces.....	63	Oak Woodlands.....	107	NRCS Bird Habitat Cut .....	179
Barbed-wire Fences .....	64	Mixed Appalachian Forest.....	110	New England Cottontail Rabbit Habitat.....	181
Smooth Ground .....	64	Tobey Bog .....	114	<b>RESEARCH SITES.....</b>	<b>183</b>
Rocky Ground .....	64	Beaver Ponds .....	120	Moose Exclosures.....	184
Bedrock .....	64	<b>LAND USE HISTORY .....</b>	<b>124</b>	Forest Succession Dynamics Study .....	186
Canada May-Flower.....	65	Charcoal Hearths.....	125	American Chestnut Plantation .....	189
Japanese Barberry .....	65	S. Dean Homestead (Meekertown).....	129	Genetics Studies at the Yale Pine and Fir Plantations	
Apple Trees.....	66	Southwest Stone Walls .....	131	(Francois Mergen).....	192
<b>SITES OF INTEREST .....</b>	<b>67</b>	Norfolk Downs Golf Course.....	134	Pitch Pine Plantation Study.....	194
<b>GEOLOGIC AND GEOMORPHIC SITES .....</b>	<b>67</b>	Mansfield Site.....	136	Carbon Flux Tower.....	197
Bedrock .....	68	Dorman Farm.....	138	<b>RESEARCH BIBLIOGRAPHY .....</b>	<b>202</b>
Glacial Lake Norfolk .....	69	Pioneer Cabin on Number 4 Trail .....	146	<b>COMPLETE SPECIES LIST .....</b>	<b>208</b>
Slide Areas on Brown Brook.....	73	Brown Brook Sawmill.....	148	<b>ACKNOWLEDGMENTS.....</b>	<b>221</b>
Talus and Glacial Lake Hollenback.....	74	Dean Farm at the Jean Trail.....	150		
Roche Moutonnée.....	76	<b>FOREST MANAGEMENT .....</b>	<b>154</b>		
Natural Lakes.....	78	Plantations .....	157		
Iron Trail and Stoneman Summit.....	80	High Pocket Timber Harvest .....	161		
Bishop's Cave .....	83	Sky Line Drive Timber Harvest .....	163		
<b>UNIQUE NATURAL COMMUNITIES .....</b>	<b>89</b>	Wapato Lookout Timber Harvest.....	165		
Rich Talus Slope .....	90	Red Pine Salvage Operations.....	167		
Red Spruce Swamp .....	95	Lowland White Pine Thinning .....	169		
Old Growth.....	98	Witch Hazel Harvest.....	172		
Balds and Rocky Outcrops.....	102	Maple Syrup Production.....	174		







# FOREWORD I

PROFESSOR SIR PETER CRANE

Generations of students from all over the world have had their formative introduction to the Yale School of Forestry and Environmental Studies, and in many cases their first encounter with the landscape of North America, through the time they have spent at Great Mountain Forest. Invariably, that experience, in the company of remarkable peers in a unique place, has made a deep impression. Very often it has changed lives: and it has come to be pivotal in helping create the special community that is “F&ES”- our School. None of this would have been possible without the foresight of the Walcott and Childs families, more than a century ago, to acquire a large tract of seemingly unpromising land, and then to engage actively in its management. Great Mountain Forest is testament to the value of enlightened and purposeful multigenerational stewardship working with the inherent resilience and beauty of nature.

The Yale School of Forestry and Environmental Studies is just one of the many beneficiaries of the vision that Great Mountain Forest represents. This book illuminates the full riches of this unique palimpsest with empathy for all its treasures. And it encourages us to look carefully and deeply to understand how this landscape has been produced by contingent and complicated processes operating at multiple geographic and temporal scales. This book places Great Mountain Forest in context: as part of the ever changing green mantle of northwestern Connecticut formed by climatic succession over millennia on an ancient landscape that has been influenced pervasively by people. Geology, geomorphology, ecology, land use history and forest management are all integrated to bring to the surface how much there is to see, once our eyes have been opened. There is much to be learnt from Great Mountain Forest, not just about the particularities

of a spectacular tract of Eastern Deciduous Forest, but about the general principles of how landscapes are born and the forces by which they are created.

This project was seeded by Dan Jones—a distinguished graduate and longtime friend of the School of Forestry and Environmental Studies. He had already pioneered the “special places” approach at Yale Myers Forest, and then applied it more extensively in his remarkable project at The Parklands of Floyds Fork. During a visit there in 2014 I had the opportunity to understand how that approach could transform the pedagogical value of Great Mountain Forest and to realize immediately that Michael Gaige was the right person to take on this task. We are truly fortunate that Michael agreed, and his unique talents are visible on every page of this landmark work. I also must thank Yoni Glogower for committing himself so wholeheartedly as Michael’s apprentice in this project, and also Mary Tyrrell and Hans Carlson for being the primary Yale and Great Mountain Forest contacts for the Gaige-Glogower team. Without the help of Mary and Hans, as well as the assistance and support of many others, this project would never have seen the light of day.

For me, in my last few months at Yale F&ES, this project has special personal resonance. Great Mountain Forest is one of the most beautiful places in Connecticut I have encountered. But almost half a century later, this project completes one arc of my own career by connecting the future of field experiences at F&ES to my early introduction to fieldwork in the UK. Well before college, I was fortunate to learn about the “Making of the English Landscape” not just from W. G. Hoskins classic book, but by walking the muddy fields and village lanes of Northamptonshire in the company of John Steane, a thoughtful and inspirational observer. I hope that the resources so carefully and brilliantly documented in this book are just as effective in opening the minds of future generations of faculty and students to the extraordinary resource that Great Mountain Forest represents.

Finally, I want to place on record the great indebtedness and sincere thanks of all of us at the Yale School of Forestry and Environmental Studies for the kindness and generosity of the Childs family over multiple generations. We have all been the beneficiaries of their continuing vision, as well as their welcoming and inquisitive spirit.

— Professor Sir Peter Crane FRS  
Carl W. Knobloch Jr., Dean  
School of Forestry and Environmental Studies



## FOREWORD II

GREAT MOUNTAIN FOREST: LANDSCAPE AND LEGACY

HANS M. CARLSON PhD

Great Mountain Forest is 6300 acres of working conservation land, established more than a century ago in the hills of northwest Connecticut, and now protected under a Forest Legacy easement. It is a unique place, and this book is an in-depth examination of the forest's ecology and the land-use history that shaped that ecology. The book's focus is the call and response between humans and the natural world, and though specifically about GMF, it offers interpretive lenses which will be useful in many places. As you learn to read the forested landscape here, I encourage you to think beyond the boundaries of this one property, for this book's lessons are broader than any one tract of forest in southern New England. I also encourage you to think outside the ecology and land use as you look at GMF, for while the forest is a compelling set of ecological communities, Great Mountain is equally compelling as a set of ideas. The two are intimately linked in fact.

In 2003, the Childs family, who then owned GMF, sold the development rights on the forest and put ownership under a nonprofit foundation (NGO) which now carries on its management. These changes were new ideas in

the history of this place, and there is an interplay of ecology and human thinking here worthy of your consideration, for both the easement and the symbiotic relationship between forest and nonprofit continue to shape the land. So, while this book is focused on the physical forest, and one of its central themes is that the history of human work has shaped natural communities, I also want to highlight the important legacy of human ideas here. At Great Mountain Forest, things like values, policies, and institutions have always defined the physical place, and this too is broader than our one piece of forestland in northwest Connecticut.

Human thinking has shaped this forest since the end of the last ice age, in fact, and ties GMF to a wider history. Before the early eighteenth century, Native people used and stewarded this forest, and archeologists are still piecing together the full ecological effect of pre-contact Native land use in places like GMF. We know they altered forests with fire, as well as by selecting for desired trees and plants; Native peoples also changed the forest with agriculture and hunting. And since we know that humans never do anything without conceptualizing

their actions, we know too that there was a whole intellectual context which underpinned Native use here. The Eeyou people with whom I work in northern Quebec often call the boreal forest “their garden,” and this metaphoric understanding of Native land use and stewardship applies historically to the forests of New England. There are only a few sites on GMF that can be definitively identified as Native, but their land use and thinking helped create the original conditions found all across the northeast. Their presence should still be felt in looking at this forest.

Connecticut colonials claimed sovereignty over this region from first settlement of coastal areas, though Euro-American occupation began here only in the early 1700s. In Connecticut’s northwest corner, as everywhere during the period, this was largely agricultural settlement, focused on clearing the best land first. Colonials built farmsteads, and put land into crops or grazing for sheep and cattle. Higher terrain, including most of GMF, was not particularly good for agriculture, but those who farmed here often ran sawmills or made charcoal for the local iron industry as ways of compensating. Charcoal was a local variant on clearing and settlement, and the centrality of agriculture was overshadowed by ironmaking in the early industrial revolution. Much of what became GMF was owned directly by iron manufacturers, and these parcels particularly were cut over four or five times in the nineteenth century. The result was a largely deforested landscape, swaths of it burned over and ecologically impoverished by overuse.

Much of this Euro-American use is still visible on the ground and this book will help you see that our forest is the result of all this work. Remnant cellar holes and overgrown farms left ecological changes in their wake. Meekertown, in the southern part of GMF, though fully reforested now, is the site of milldams, a cemetery, and the glacial erratic boulder known as Townhouse Rock, where resident colliers held community gatherings. There are also hundreds of colliers’ hearths around the forest, where Meekertown residents smoldered logs into charcoal. GMF and surrounding lands are scattered with these leveled areas where altered soil chemistry continues to shape ecology. All that human action represents the first dramatic post-settlement change to GMF’s ecology, and a walk through Great Mountain Forest, then, is very much a walk through culture and time, as well as through ecology. This will be made clear by what follows in this book.

Here, however, it is worth noting again the power of human thinking, for all of this settlement activity, and the altered ecology, was

an outgrowth of the ways people thought about the land as well as their actions. The English who settled this region divided land into private plots as quickly as they could, reshaping Native tenure. Private property carried with it the full weight of centuries of thinking about the rights and responsibility of ownership. True ownership meant “improvement,” by which settlers meant farming and building, and this in turn was driven by understandings of what it meant to be “civilized” and Christian. In the industrial period, work was carried out in the name of industrial progress and national manifest destiny, and these two ideas were particularly powerful narrative forces in the dramatic nineteenth century reshaping of this land. Settlers and industrialists used these concepts and values to alter the forest, just as they used axes, saws, and colliers’ fire.

With the waning of the iron industry, and the abandonment of many upland farms, two wealthy New York businessmen, Starling W. Childs and Frederic C. Walcott, began buying land in Norfolk. Here they established a game preserve, eventually calling it Great Mountain Forest, and applying principles of conservation in order to regrow game populations. This began the second great transformation of this landscape, for this is when the forest returned. I’ve said that the nonprofit conservation organization is new to GMF, but the legacy of conservation thinking which is its mandate, began with Walcott and Childs. This was built upon by Childs’ son Edward C., better known as “Ted,” who took over for his father after he graduated from the Yale Forest School, in 1932.

Ted Childs, in 1952, bought out the Walcott interest and with forest manager Darrell Russ, refocused efforts on working forestry, research, and land conservation. This more-holistic approach continues to define our working relationship with the land at GMF, and the forest you experience has been shaped by a century of this kind of stewardship thinking. Conservation is thus part of the historicized landscape and, like reading the history of cellar holes and colliers’ hearths, this book will help you identify and understand forest cuts, plantations, and research sites. It will help you put them into relation with the farming and charcoaling that preceded them, for these activities form a continuum of human activity.

That said, conservationism represents an attempt to rethink land use, and this was a break with the past. Forests regrew in many places across the northeast when farms were abandoned and the iron and timber industries moved west, but only a few places became the focus of active forest management and conservation planning. During the period in which GMF was established, forest conservation was happening largely on western

federal land, rather than private land. New England, though it was one of the birthplaces of American conservation thinking, was late to implement large conservation efforts. So while many wealthy individuals like Childs and Walcott bought properties away from eastern cities, most were managed as country estates, not as forests or game reserves. In this regard, GMF is special, because while the two men bought land as a place to hunt, Great Mountain Forest was also established as a laboratory for conservation thinking.

As you walk through Great Mountain Forest, then, keep in mind that you are traversing a landscape of Walcott<sup>1</sup> and Childs' conservationism, which was begun "to see what [might be] adapted to Connecticut waste woodlands."<sup>2</sup> Or, as Walcott described it to a friend:

Tobey Pond looks like a lake in a Zoological Park. We have from two to five hundred ducks there all the time now; they have stopped over on their way South, attracted by our own ducks, numbering now more than two hundred and representing fourteen different varieties. The deer from fall feeding have become quite tame and from three to five are in sight from the house every day. We saw one swimming across Tobey Pond yesterday afternoon. The pheasants are flourishing and we have quite a large number of them now – breeding stock for next spring.<sup>3</sup>

Forest management here is a continuation of that effort, and while methods have evolved greatly, Walcott and Childs' idea that land could be conserved and still offer public value is still a large part of our philosophy.

Theirs was a private endeavor, but it was carried out with public benefit in mind. As Walcott wrote to William T. Hornaday, then at the New York Zoological Society, in 1912, "there are about 150,000 acres, roughly speaking, of land that should be taken up by the State for the benefit of the public. They should be stocked with birds and deer, and intelligent forestry carried on throughout these tracts."<sup>4</sup> Connecticut lagged in this kind of

conservation thinking, but the two men worked to shape public policy. Again, in Walcott's own words:

The entire State of Connecticut is gradually waking up to the importance of conserving its forests and wildlife and rehabilitating its wild land, as a result of a campaign of education that Star and I have been carrying on for nearly a year, and the culmination of this campaign came this last week-end when the new Forest, Fish & Game Commission - consisting of eight men recently appointed by the Governor in place of the old Commission (all the direct result of our persistent efforts to clean things up) – spent the whole weekend with us. The new Commissioners are so enthusiastic over what can be accomplished, as shown by our place, that they have determined to set aside a large area of State land for a game refuge.<sup>5</sup>

Walcott became a public champion of both public and private game preserves, giving lectures and publishing on the subject. "I am going to show them what we have been doing in reclaiming land and preserving game"<sup>6</sup> at GMF, he wrote, and all of this led one local official to note Great Mountain Forest's "considerable importance to students of natural history."<sup>7</sup>

Walcott became Connecticut's U.S. Senator in 1929, serving until 1935. He was a Republican and did not win re-election during the New Deal, but during his term he worked on a progressive wildlife agenda as a member of the Agriculture Committee. He won approval for a subcommittee on Wildlife Resources Conservation and was made its chair, serving in this capacity until 1935. He supported the creation of the Civilian Conservation Corp in 1933, largely because FDR promised that CCC projects would include recovery of wetlands for migratory waterfowl. Walcott was central in creating the Duck Stamp program – a way of funding habitat preservation and restoration that continues to this day.

Out of Congress, Walcott remained active in conservation organizations and was recognized as one of the movement's founders. Importantly in the history of GMF, he also began to think beyond the

---

1 I am indebted to Mark Jones, retired Connecticut State Archivist, for sharing the source material related to Frederic Walcott which I have used here. Mark is researching a biography of Walcott, which will be out in the near future.

2 Frederic Collin Walcott Collection #529 at the Manuscripts and Archives department at the Sterling Memorial Library, Yale University. 4 September 1912, FCW to William T. Hornaday, New York Zoological Society, FCW Coll. #529, Box 2, Folder 10.

3 9 December 1912, FCW to Dr. William H. Welch, FCW Coll. #529, Box 2, Folder 11.

4 Frederic Collin Walcott Collection #529 at the Manuscripts and Archives department at the Sterling

---

Memorial Library, Yale University. 4 September 1912, FCW to William T. Hornaday, New York Zoological Society, FCW Coll. #529, Box 2, Folder 10.

5 15 September 1913, FCW to Mrs. F[rederick] S. Kellogg [sister], New York Mills, New York, FCW Coll. #529, Box 2, Folder 15.

6 23 September 1915, FCW to Mrs. F. S. Kellogg [sister], New York Mills, N. Y., FCW Coll. #529, Box 3, Folder 23.

7 23 June 1913, G. C. Warner to Hon Donald T. Warner, Salisbury, Conn., FCW #529, Box 2, Folder 13.

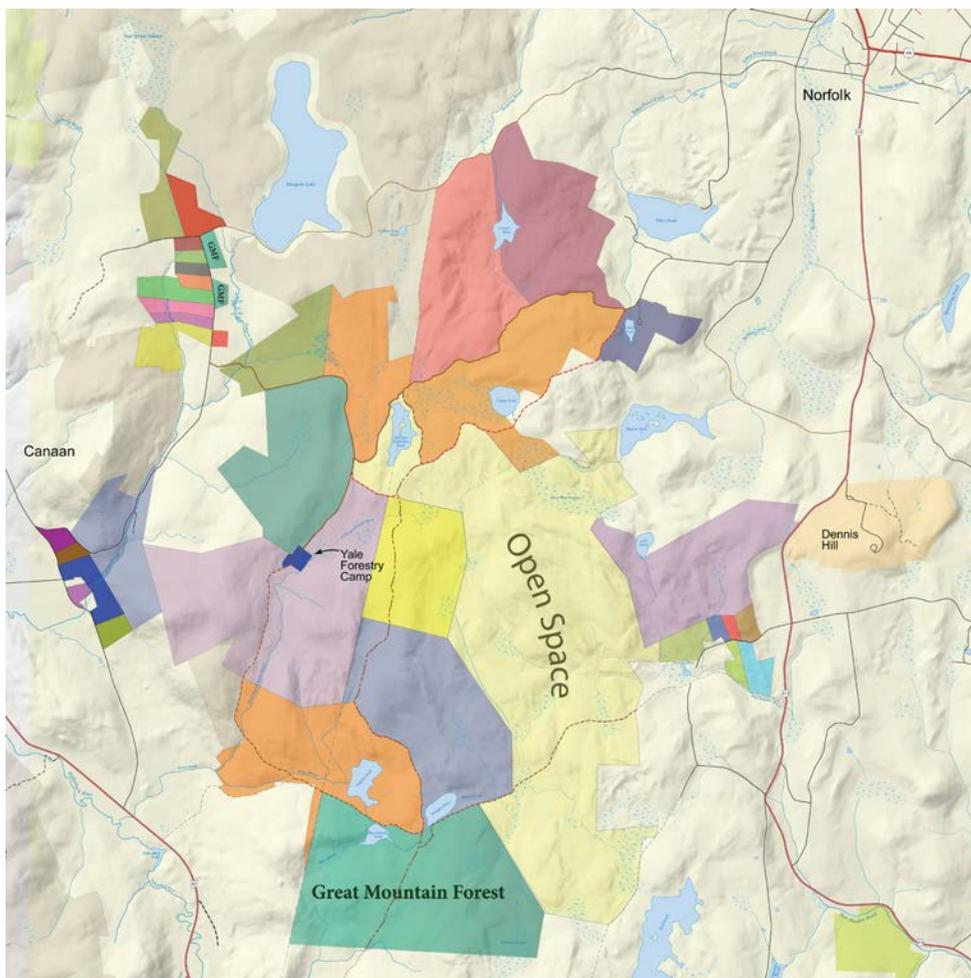

From the development appraisal, 2001 (LandVest project #3198), produced for Elisabeth Childs, as part of the easement negotiations. The colored areas are the “kingdom lots” and smaller building lots which represented highest market value of the forest. The appraisal was meant to put a value on the development rights.

conservation of game species and move toward a broader understanding of natural resources, even ecosystems. By the 1940s, he was arguing that broader protection would help all specific efforts, though earlier he and Childs hired hunters to kill all “varmints” [predators like foxes] at Great Mountain Forest, in order to protect favored species. In all these ways Walcott came to see the necessary interconnections in nature, a development in thinking he shared with other conservationists like Aldo Leopold, with whom he corresponded.

Importantly, Walcott also began to believe that governments should increase the scope of conservation policy and public conservation education. Here he was prescient, for while earlier conservation was arguably driven by elites, ever-increasing public understanding has been the hallmark of the post-war period. I will say more below about Great Mountain Forest’s part in this period, but first I want to highlight the fact that policy and public support have everything to do with the current forest about which you will learn in this book. Great Mountain Forest has been, and continues to be a model for public action, but only because of decisions made outside the forest by lawmakers and bureaucrats. Here is where you want to keep values and ideas in mind again, and particularly how they have manifested themselves in policy.

As you investigate the forest, you will learn to think of GMF as a territorial whole, becoming familiar with the woods road running between the main gates, and the Chatleton Road and Number Four Trail running to the south end of the forest. Tobey Pond, in the north part of GMF, will be connected naturally in your mind with Wapato and Wampee Ponds, in the south; Meekertown will be connected with The North Forty, though they are miles apart. You will learn to understand the various places highlighted in the write-ups and field descriptions, and get used to seeing the shape of GMF’s ten square miles on a map. This block of land may even begin to seem a foregone historical conclusion, but just as you will learn not to think of a coppiced oak tree in the forest as simply a natural fact – seeing it instead as a clear sign of human activity – neither should you think of GMF as simply “natural.” Things like easements and nonprofit institutions are also landmarks that locate you culturally and historically in the landscape, and these are the culmination of a century of conservation thinking.

Take the map on the left as an example, because here is another kind of “natural” outcome of human thinking, and one that is more in line with common use than are easements and nonprofits. When the Childs family sold the development rights to the forest, in 2003, the land’s potential had to be established, and the map shows its highest market value. The plan called for the majority of the land to be split into “kingdom lots,” and some of the peripheral land broken into smaller building lots. None of those features, with which you will become familiar as you read this book, would have been connected by ownership or management practice anymore, only by the history of what had once been Great Mountain Forest. Only the southern portion, already held by Ted Child’s private foundation, set up to support research, would have remained, and GMF would have been six hundred acres, not six thousand.

The fact that there was never any intention to proceed with this development plan takes nothing away from the importance of this picture or the ideas it represents. It highlights that the forest which seems like a natural fact is

very much not the “natural” outcome of the way our society generally thinks about real estate. Remember, the map illustrates our collective ideas of highest and best use – the dominant set of ideas used to manage most land in this country. Remember too that it was within the system of private ownership that Childs and Walcott bought land and established their private preserve. They urged the state to put certain lands into public ownership and management, and they modeled a different kind of land use, but GMF remained subject to all the forces working on all private property.

In this context, the map of private development represents the latest variation of our society’s conceptualization of that system, and Great Mountain Forest might have been simply an interlude between nineteenth century industrial/agricultural use and twenty first century exurban subdivision. This has been the pattern in most of central and southern New England since the end of World War II: large parcels of land – mostly former farms – subdivided for residential and vacation homes, or commercial use. This subdivision has been the driving force behind forest fragmentation and the decline of habitats and ecosystems across the region. The family sold the development rights and changed the forest’s legal status to avoid this fate, and a different set of ideas now applies to GMF. This was thanks to land-use and tax policy structures which allowed the sale of rights to the U.S. Forest Service and the State of Connecticut, and also allowed the expansion of the nonprofit to its current form.

The history of both easements and nonprofits is important here, since both are departures from standard thinking in ownership and management. Starting in the late 1880s, early easements were used to protect the Boston parkways designed by Frederick Law Olmstead. The National Park Service used easements to protect some of its own parkways in the 1930s too. Similarly, Wisconsin used easements to protect riversides and parkways in the 1950s, but up to that point these were the only easements in the country used for conservation efforts. This was because even Massachusetts and Wisconsin had no specific statutory authorization for their use. Without legislation giving easements specific legal status, they were of dubious legitimacy, for they hinder development, and this is still disfavored in common law. It goes against that historical understanding of highest and best uses of private property.<sup>8</sup>

Easements need special authorization to hold up in court, and starting in 1954, Massachusetts passed legislation specifically giving them

legal status for government use. In 1969 the state gave that same legal right to private owners, and by 1984, twenty-nine states had written similar land protection into their laws. Meanwhile, changes in the federal tax code made it more and more desirable for landowners to sell development rights to offset the rising tax burden that came along with owning large pieces of land. With government and foundation money available to purchase easements, this kind of conservation has grown exponentially. According to the National Conservation Easement Database, there are now more than 114,000 easements nationally, covering 23 million acres. The legal and financial benefits given for protection, thus, have dramatically changed land use in some places, and represent a major shift in thinking about the land.<sup>9</sup>

Great Mountain Forest gained its easement in 2003 under the Forest Legacy program during this surge in easement use. The program was a feature of the omnibus 1990 Farm Bill, and aimed specifically at protecting working forestland from conversion to non-forest uses. This was the same year GMF became a private operating foundation. The growth of nonprofits follows a similar historical trajectory to easements, with numbers and popularity increasing with the same changes in tax policy. Nonprofits became an even more important feature of the American landscape with the conservative move away from government, beginning in 1980 and continuing to the present. Whether it’s local land trusts or The Nature Conservancy, nonprofit status allows engagement with conservation efforts while easing personal or corporate tax burdens, and today, more than 36,000 easements are held by NGOs like GMF.

While Great Mountain Forest is still private property, the use of these two legal structures means that ownership here is not the typical fee simple control common to most U.S. private property. This represents a rethinking of land in the name of conservation, and means that Great Mountain Forest did not form a bridge between the nineteenth century ownership of iron-makers and twenty first century development. Instead, the conservationism planted here in 1909 by Childs and Walcott, found its way forward in history, and back onto the land in this forest. These changes tied the forest and nonprofit into the relationship they now share, and linked the early conservation movement with the development of Great Mountain Forest as an institution. They also tie earlier conservation together with the working forestry and management practiced at GMF, and this is the final aspect of human thinking that should inform your

---

8 Zachary Bray, “Reconciling Development and Natural Beauty: The Promise and Dilemma of Conservation Easements,” *Harvard Environmental Law Review*, Volume 34, 2010: 124-131.

---

9 <http://conservationeasement.us/>

investigation of the ecology and land-use history of GMF.

At the beginning I said that this was a working conservation forest, and the Forest Legacy program was designed specifically to protect both what we do on this land, and how we conceptualize it. Landscape restoration was the initial motivation behind conservation here, but Ted Childs and Walcott in turn shifted the management focus at GMF, away from game management and toward management of the whole forest. When Ted Childs took full control of the forest, and hired Darrell Russ to manage it, forestry, research, and education also became part of the GMF program. Here the growth of professional forestry, embodied in Child's and Russ's graduate educations, built on the growth of Walcott's conservationism and his belief in public education in conservation.

We are now decades into this development of land-use thinking. While the central idea continues to be that human activity can conserve and improve, specific human actions have to be done within a holistic understanding of the forest, guided by scientific research and an aesthetic sense of the forest. And here is where the story of Great Mountain Forest is something special in the latter half of the twentieth century, and where we should pick up the historical thread that we left with Walcott.

Until 1940, work at GMF was part of the mainstream of conservation thinking and action in the United States. This was a national movement, and members of both parties worked to create policies implemented by government agencies and private citizens alike to protect and manage public and private lands. Beginning with WWII, however, the booming economy pushed into the country's resource base, particularly in the west, which had been the focus of conservation efforts in the decades before the war. The U.S. Forest Service, created by Theodore Roosevelt and Gifford Pinchot for the purpose of stewarding the nation's forests, became increasingly focused on maximizing use. The same was true of water and mineral resources in the west, which were developed at an increasing rate. With the memory of the Depression and the war close at hand, the nation largely forgot the lessons learned a generation earlier and focused instead on economic expansion and increased prosperity.

The eventual reaction against this wave of resource extraction was the modern environmental movement, born out of fights to protect western wilderness areas, like the Grand Canyon, as well as against the suburbanization of the American hinterland, and the increasing pollution that came with industrialization. These spawned David Brower's Sierra Club campaigns, Rachel Carson's *Silent Spring*, and Gaylord Nelson's

Earth Day. This also drove the passage of clean air and clean water laws in the 1960s and 1970s, and was the beginning of the global vision of the environment that we take for granted today. Since the birth of modern environmentalism, people have become focused on ozone depletion, the devastation of Amazon forests, and protecting the Arctic National Wildlife Refuge, but this has also affected their relationship to more local places like GMF.

In one respect modern environmentalism was an heir to earlier conservation, but there was also a difference between the two movements' understandings of that call and response between land and people. In reacting to massive, modern damage, environmentalists often argued that caring for the land meant leaving it alone. They took their inspiration from wilderness prophets, like Thoreau and Muir, not from conservationists like Pinchot and Walcott, and often painted all modern human action as inherently destructive. There continues to be a great deal of evidence to back this perspective. But there is also an inherent irony, in that many people who consider environmental issues important do not have any working understanding of the land, or our continued need for resources.

In the half century since the movement started, Americans have increasingly lived apart from anything other than a recreational relationship with the outdoors, even as they have become invested in global efforts to save "the environment." In many respects Walcott's worries about future conservation have been fulfilled, in that few people have any education in working with nature. Aldo Leopold once wrote that there were "two spiritual dangers in not owning a farm. One is the danger of supposing that breakfast comes from the grocery, and the other that heat comes from the furnace." Arguably the same danger arises in thinking that wood comes from the lumberyard.

While Americans have learned much about the environment as a whole, and we have done some to preserve it, we have forgotten that careful and caring use of the land is necessary. The only other option is to push our use over the horizon where lack of public oversight leads to a great deal of global environmental damage. We have forgotten that there was a time when we had to get our timber from places like GMF, and that the mistake was not in using the land, but in overusing it.

Protected by Ted Childs' financial ability to carry on private conservation, and situated in a region protected from both industrialization and suburban sprawl, largely by the money created by the booming economy, GMF stood apart from a good deal of this history. It's not that

GMF was isolated from environmental issues or policy: Childs served as Forest and Parks Commissioner for twenty four years, for example, and he and Darrell Russ instituted the Tree Farm Program in Connecticut. Childs gave Yale University its forestry camp at GMF, underwrote his own intern program, and funded dozens of research projects, all as a way of engaging with education and environmental issues. In all these ways GMF was important in civic and political activity. But here in the forest ideas about working forest conservation that most of the country left behind with WWII were carried forward. These ideas continue to underpin the belief that people can engage with the land, and if they do it with intelligence and caring, then they can make something for themselves and make the land better too.

We will continue to work with the land here with internal conservation ends in mind, and this will continue to affect the nature of the forest – the stands of trees that we harvest, the ones we leave, the sap we collect from the sugarbush, the habitats we manage. I would also like to believe that Great Mountain Forest, and the way we manage it, will continue to contribute to conservation beyond our boundaries. I hope this especially now, when the global environmental perspective is shifting, to remind us that we all live in one another's backyards. Thinking about and working this forest is the educational as well as the conservation legacy which we carry forward. It is a legacy that I hope you will come to value as you investigate this forest, its ecology, and its history.

Enjoy your time in the woods.

— HANS M. CARLSON PhD  
Great Mountain Forest Director  
October, 2015





## INTRODUCTION

Brushing through thick mountain laurel and coppiced oaks in Great Mountain Forest, it is hard, at times, to remember you're in Connecticut. The forest is dense. And when you're on foot, it's vast. From atop Blackberry Hill, you see no houses, nor malls, nor roads. Lower down you frequently pass the stony anachronistic remains of a past culture, really no different than passing an overgrown Mayan temple.

Great Mountain Forest offers the world a host of services and opportunities. It offers a place for moose to mix, oddly, with tulip poplar trees. It offers a southern extent for boreal black spruce bogs in New England. It offers some of the finest vestigial old growth hemlock stands in the northeast. Great Mountain Forest's landscape unfolds like a storybook of American history. And for the past century or so, as a result of that history, it has provided the world a success story of conservation, a protected area reserve for biodiversity, and a small but important carbon sink in an age of rapid carbon release.

It also offers a textbook in forest ecology and forest management. It showcases the complexity that results from natural ecosystems at the intersection of cultural landscapes and the intentions people have imposed on millions of years of evolution and adaptation in North America's temperate deciduous forest. Getting on the ground and reading the landscape at Great Mountain Forest means keeping one eye on Earth's natural history – its deep time history, fundamentals of biology, and principles of ecology – and the other eye on the ways humans have made habitat for themselves among this complexity.

This field resource book is intended to enable the reader to approach this vast forest with some direction on what is out there, where

to go, and to provide details on what it is they are observing. The goal is to open the great textbook that is GMF to Yale FES students and faculty who may find the expanse of the place intimidating, or overwhelming, as a launching point for study. It is our hope that the project will be mutually beneficial for Great Mountain Forest staff and their programming and management.

This project has its roots in a similar project by Daniel H. Jones (Yale FES, MF, 2006) titled *The Quiet Heart of the Quiet Corner: A Guide to the Natural History of the Yale Myers Forest, Tolland and Windham Counties, Connecticut*. In that project, Jones took a slice of Yale Myers Forest centered on the Blue Trail and introduced readers to the process of reading the landscape by, perhaps most importantly, bringing them to the places on the ground that tell the stories of the Yale Myers forest. As the great Japanese poet Matsuo Bashō (1644-1694) said, “If you want to learn about the pine, go to the pine.”

Jones and co-author of this book (MHG) later carried out a similar but much larger special places project in the rich deciduous forests and abandoned farmlands around Floyds Fork of the Salt River in Louisville, Kentucky – Jones’ hometown. There, Jones’ organization, 21st Century Parks Inc., had been acquiring properties to build a systemic new addition to Louisville’s celebrated Olmsted park system. Called The Parklands of Floyds Fork, that land today is nearly 4000 acres of interconnected, permanently protected parkland open to the public with hiking, biking, and paddling trails, and quiet patches of forest and meadows. The special places approach fed directly into the planning and design elements of The Parklands and set a foundation for educational programs. Today, when interpretive staff in The Parklands of Floyds Fork lead a group to a successional stand of eastern red cedar, or a hiker walks a trail and enters a forest of rich spring ephemerals, passes a 400-year old chinkapin oak, or a stone wall, they experience the intentionality behind the special places idea and its roots in Yale Meyers and FES.

The process used to uncover the sites is referred to as “reading the landscape.” As Jones (2007) notes in *The Quiet Heart of the Quiet Corner*, “Reading a landscape requires knowledge of both the vocabulary and the grammar of a place. The vocabulary includes things such as the names of plants and animals, rock formations and soils types. The grammar consists of the major processes that shape a landscape such as geologic events that have influenced its topography and soil formation, its natural and human disturbance history, and the interrelationships between the different life

forms and the surrounding environment.” It is this reading the landscape process that is at the heart of this GMF field resource guide.

This guide is designed to make exploration and learning at GMF easily approachable. We tried to focus much of the content around areas easily accessible from Yale Camp, however, some excellent features are distant from there. The first three sections describe the background story. The Geological Underpinnings describes how the bedrock, topography, and glacial geology happened and how those aspects played a role in the contemporary forest. The History of the Eastern Forest, describes with some detail the deep time origins of the eastern forest, the most diverse temperate deciduous forest on Earth. And the Human History describes the way people have inhabited Northwest Connecticut and Great Mountain Forest in particular since the end of the last glacial period to the present.

The second section outlines some of the significant species found at GMF and specific information on their presence here. The history and presence of moose, for example, or eastern hemlock, is described with regard to this particular landscape.

A section on Landscape Field Marks follows. Designed to be a stand-alone document, this section shows, through photographs with brief narrations, many of the common features found at GMF that, when observed and interpreted, reveal something deeper about the processes taking place. Just as we use field marks of a bird (e.g. wing bars, bill shape) to aid in identifying the species of bird, we can use landscape field marks to aid in identifying pattern and process of a site’s history and ecology.

The next sections detail the special places where one can observe, learn, and research some of these themes. The Geological Places, for example, describes locations to observe GMF’s glacial lakes, various substrate types and more. The Natural Communities section describes 8 exemplary community types found within GMF’s matrix forest (also described). These span from lowland spruce bogs, old growth forests, and dry rocky outcrop communities. The Cultural Landscape details 10 sites of previous land use. Old farms, sawmills, and miles of stone walls are described with detailed maps, GPS coordinates, and more. Forest Management, done with intention since the days of Ted Childs, is given its own section where we described several of GMF’s harvest areas and plantations with detailed harvest dates, species, regeneration, and more.

A final section lists all the known environmental research that has been done at Great Mountain Forest. This substantial list amounts to over 100 published studies. GMF has always promoted a variety of research

projects on its land, and this section seeks to illustrate that dimension of their outreach efforts. GMF has worked with and allowed not only Yale FES projects, but also researchers from many academic institutions and non-governmental organizations. The intention behind all of these sections is to document and share the best places on the ground to observe, learn and study GMF ecology and history and the intersection of the two.

As substantial as this project turned out to be, we believe we have only scratched the surface, literally and figuratively. Each site or species or field mark could be described in much greater detail. The trove of historical information could be explored more thoroughly. The landscape could be scoured with a finer lens, looking for both the subtle and at times dramatic ways these ecosystems function, and the ways humans have added to the complexity of Great Mountain Forest's landscape. By viewing this landscape through a lens to observe natural processes (species interactions, evolution, plate tectonics) and a lens to view human driven processes (forest cutting, settlement, land protection), we find at Great Mountain Forest the two lenses inseparable.





# GEOLOGIC UNDERPINNINGS

## THE PHYSICAL LANDSCAPE OF GREAT MOUNTAIN FOREST

Understanding a place, from its specific vegetation and fauna, to the various ways people have approached and shaped the land, necessitates beginning with geology. At GMF (as elsewhere) its nature and the history trace back to its geologic foundation. The cold summers (“Connecticut’s Icebox”) are driven by geology. The acidic, poor agricultural soil is driven by geology. The dominance of oak, northern hardwoods, and hemlock, is driven by geology. The rich talus wildflower community owes its existence to geology. The Forest’s charcoaling history happened because of geology. And, the fact that a 6000-acre block of protected forestland exists in northwest Connecticut is, in fact, driven by geology. This brief introduction to the geologic story of Great Mountain Forest, and by extension Northwest Connecticut and New England in general, is intended to provide the reader enough geological background so they can more fully appreciate the complexity in the sites characterized in this document.

There are two critical background topics to review before any understanding of geology can take place. First, are the basic rock types. Geologists describe three basic rock types: igneous, sedimentary, and metamorphic. Igneous rocks began as molten lava beneath the surface of the earth. Igneous rocks may cool above the surface as a volcano (extrusive igneous rocks), or they may cool and harden deep below the surface (intrusive igneous rocks). Granite is an intrusive igneous rock. Sedimentary rocks are composed of eroded material, deposited and later coalesced into rock. Sandstone (derived from deposited sand) and limestone (from deposited marine shells) are sedimentary rocks. Metamorphic rocks may have begun as Igneous or sedimentary rocks, but then deep below the surface the forces of heat and pressure alter the rock enough

that it recrystallizes. Metamorphic rocks may be “cooked” or squished multiple times and/or to varying degrees. Great Mountain Forest contains metamorphic rocks derived originally from sedimentary and igneous rocks. Northwest Connecticut contains all three types of rocks.

The second background process needed to understand geology is plate tectonics. The theory posits that the Earth’s surface is broken up into a system of plates and these shallow lithic rafts float on a molten mantle. Slowly, through convection processes, the plates move around, coalescing, subducting, scraping, and bumping into one another. This process gives rise to volcanoes, mountains, earthquakes, and even the continents and oceans themselves. Plate tectonics is the driver that creates and erodes rocks and thus forms sedimentary, igneous, and metamorphic rocks.

## GEOLOGIC EVENTS

Geology is a vast topic and a proper understanding involves more depth and breadth than is provided here. Nonetheless, with important elements of geological background behind us we can outline the story of GMF’s foundation.

Earth is 4.6 billion years old. For this description, however, we will fast-forward through the poorly understood first 3.5 billion years and begin with Connecticut’s oldest rocks. The table on page 3 outlines the last billion years of geologic processes in Connecticut.

The hard, old gneiss, mainly metamorphosed granite, appear as purple and lavender areas of the map. These are the overthrust blocks heaved up during the Taconic Orogeny. The map shows the Housatonic Massif in the west and the Berkshire Massif in the east as mainly purple/lavender areas.

The marbles of the Stockbridge Formation (blue colored on map) occur largely in the valleys of Canaan, Salisbury, the Hollenbeck River, and Norfolk. Marble is softer and thus more prone to erosion. The Norfolk marble area, referred to as the Norfolk Window, is a peculiar one. The overlying Canaan Mountain Schist (overthrust) was folded in such a way as to erode, exposing a window into the younger marble below. As metamorphosed limestone, made largely of calcium carbonate marine creatures and sediments, marbles create rich soils for forests and agriculture. GMF contains two areas with marble: around Toby Pond, where it doesn’t expose, and the Chestnut Orchard and the Rich Talus Slope in the west. Those sites are described in this book.

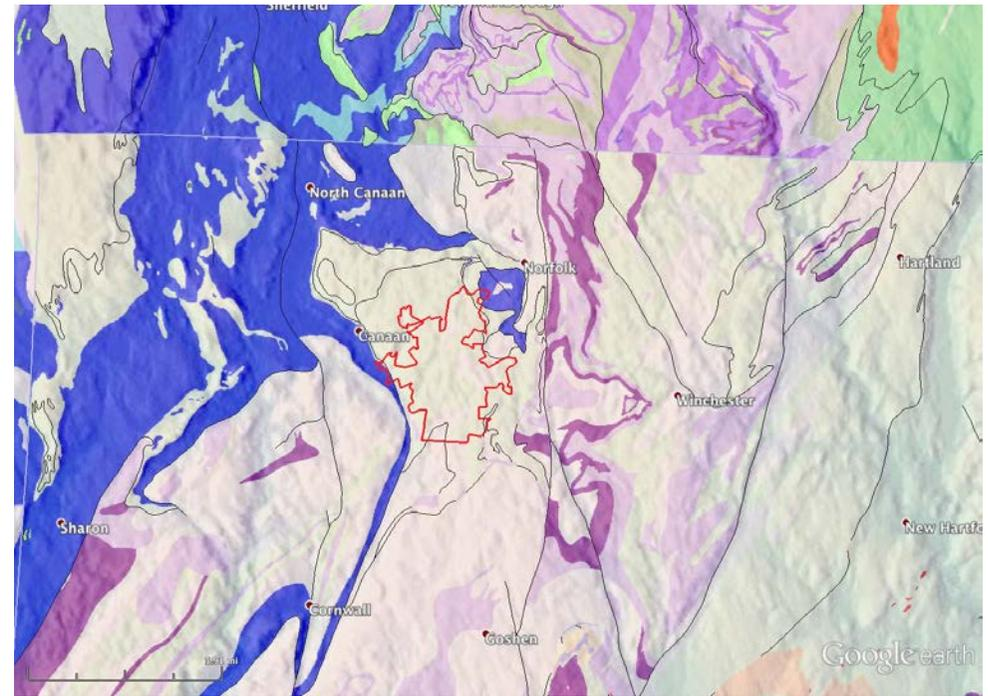

General geologic map of Great Mountain Forest (red boundary) and surrounding areas of Northwest Conn. (Geologic layers from USGS)

- Stockbridge Marble, Cambrian age: Forms small areas of GMF at low elevations near Toby Pond and the Talus Slope (Natural Communities) and Chestnut Orchard (Forest Management).
- Gneiss of Proterozoic age: oldest rocks in Conn. Forms a small portion of southern GMF.
- Canaan Mountain Schist of Cambrian age: Forms the majority of GMF rock and is exposed on rock outcrops of the Matterhorn, Stoneman, Collier’s Cliff, and Blackberry Hill (see Bedrock Sites).
- Dalton Formation quartzite of Cambrian age. This is believed to be the nearest site for pure quartzite (metamorphosed sandstone) and may be the source of the stones at the Dean Farm (see Land Use History Dean Farm).

The non-descript beige areas, which form the majority of GMF, are Canaan Mountain Schist. The rock began as sediments along the continental margin, probably eroding off the Grenville Mountains. The slabs were thrust westward during the Taconic Orogeny. Canaan Mountain Schist is much more resistant to erosion than marble and therefore forms the highlands whereas marbles form the valleys.

Several of the geological events noted in the geologic timeline do not play out directly in Northwest Connecticut rocks and landforms.

## CONNECTICUT'S OLDEST ROCKS

YEARS BP	AGE	EVENTS SHAPING GREAT MOUNTAIN FOREST / NORTHWEST CONNECTICUT
1 Billion +	<b>Middle-Proterozoic</b>	Grenville orogeny mountains rise from the formation of the supercontinent Rodinia. Metamorphosed gneiss from this event forms the bedrock of the Housatonic, Berkshire, and Hudson Massifs in western Connecticut. These are the oldest rocks in the state.
750 million	<b>Late Proterozoic</b>	Rodinia rifts apart forming the continents Laurentia and Gondwana. The gneiss, now western Conn., formed the east coast of Laurentia at the time.
500 million	<b>Cambrian</b>	Marine sediments, in an environment similar to today's Bahamas, settle in the sea east of Laurentia. These limestones will later metamorphose into Stockbridge Marble (metamorphosed limestone). Eroded sediments settle on the continental slope that will later metamorphose into Canaan Mt. Schist (the dominant rock of GMF). Schist is a meta-sedimentary rock.
450 million	<b>Ordovician</b>	Taconic Mountain orogeny ensues as an island arc similar to present day Japan, collides with Laurentia. In the process marine rocks are scraped up and thrust overtop existing continental rock layers, placing older layers atop younger layers. This includes thrusting Canaan Mt. Schist, the dominant GMF rock. The heat and pressure created by the collision metamorphosed and folded the sedimentary rocks. Thus today we find folded marbles, quartzite, schist and other metamorphic rocks from the collision. The original island volcanoes occur today as a line of meta-igneous domes in west-central Connecticut.
400 million	<b>Devonian</b>	Avalonia microcontinent collides with Laurentia causing increases in pressure on the abovementioned rocks and sediments furthering metamorphism of the rocks.
275 million	<b>Permian</b>	Additional landmasses coalesce and form supercontinent Pangaea.
200 million	<b>Jurassic</b>	Pangaea rifts apart and opens the Atlantic Ocean. The Hartford basin of the Connecticut River valley forms as a failed rift valley where Pangaea split. Basalt ridges found from New Haven to central Mass. in the Conn. River valley form as a result of crustal thinning volcanism in the rift valley.
2.5 million	<b>Pleistocene</b>	Begins Pleistocene Ice Age of repeated glacial and interglacial periods.
21,000	<b>Late-Pleistocene</b>	Most recent glacial maximum; Laurentide Ice Sheet reaches its southern-most extent. Connecticut is covered by ice. Long Island NY forms as a terminal moraine deposit from eroded Connecticut sediments. Contemporary topography of GMF is shaped.
16,000	<b>Late-Pleistocene</b>	Ice melts south to north and GMF landscape is revealed. Large glacial lakes occur in Long Island Sound, Connecticut River Valley, and NW Conn. Glacial Lake Norfolk and Glacial Lake Hollenbeck, to the northeast and southwest of GMF respectively, occurred as ice-dammed glacial lakes. Glacial Lake Great Falls occurs as sediment-dammed lake.
10,000-present	<b>Holocene</b>	Present interglacial period. Vegetation spreads from south stabilizing glacial sediments and building soil. With warming and cooling climate, GMF sees tundra, spruce forest, and deciduous forest. Humans enter and hunt megafauna-mammals to extinction. They shape the landscape to their ecology. Europeans enter and additional extinctions occur, native culture is largely eliminated, and land largely deforested. Later forest returns. Substantial amounts of carbon are added to atmosphere from deforestation and burning ancient plant matter. Humans dominate most aspects of land cover, hydrology, and many wildlife populations.

Therefore we gloss over 300 million years of time because no features from that period occur in Northwest Connecticut. From here, then, we move on to the effect of Pleistocene glaciations, especially the recent Wisconsin glacial period.

The Laurentide Ice Sheet had its origins in what is today northeast Canada. A cooling Earth allowed snow to accumulate faster than it melted. Like metamorphic rocks, when snow is put under pressure the crystals change to form glacial ice. The ice is plastic, meaning it bends and flows under its own weight and the forces of gravity. The ice, therefore, oozed down from Canada shaping the landscape as it went.

The flowing glacier carried rocks, gravel and other material to create a sandpaper-like mechanism on the landscape. Mountains were smoothed over, valleys deepened, and material moved. The original

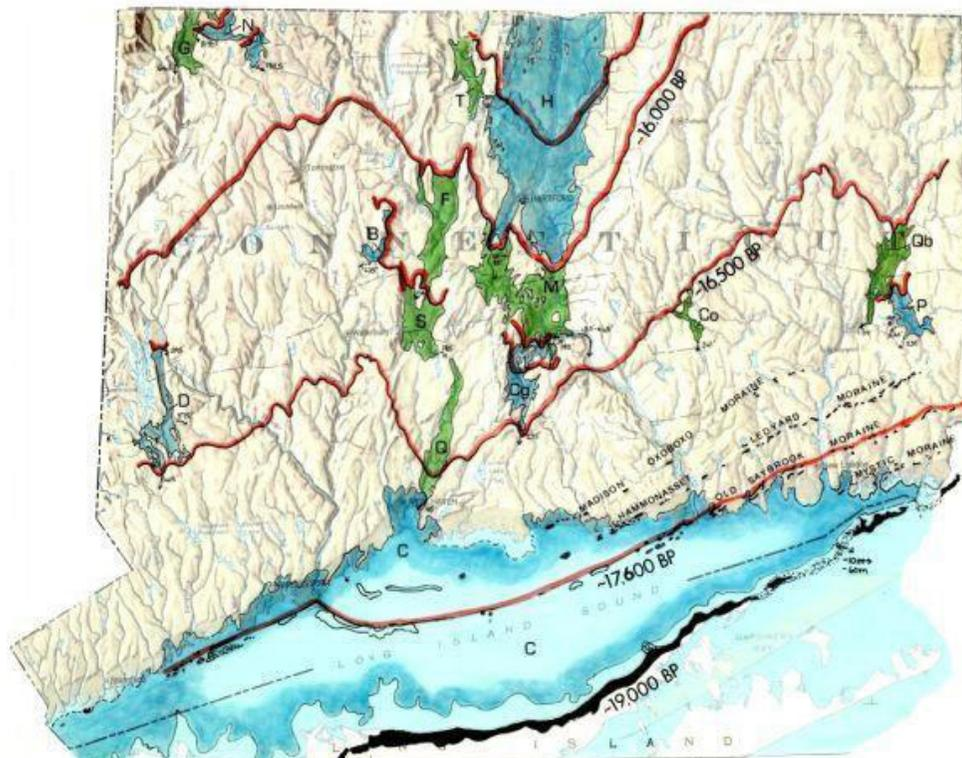

Map of glacial retreat in Connecticut. Red east-west contours show dates of glacial melting. Green and blue show post-glacial lakes. Note Glacial Lake Norfolk on the northwest corner. The lakes are identifiable today from lacustrine (lake bed) sediments. Map source: Long Island Sound Resource Center, University of Connecticut, after Stone et al., 2005.

topography guided the ice's direction, and the specific bedrock types were altered according to their properties for resisting erosion. Soft rocks rapidly eroded, while hard rocks resisted erosion.

With larger-scale planetary processes driving small changes to climate, the great ice sheet reached its peak at 21,000 years, and melted back from south to north thereafter. The map at left shows how that process occurred on Connecticut's landscape. By about 16,000 years ago, the area of GMF was deglaciated, with melting, glacial lakes formed as a result of sediment dams and ice-dams. The map left shows the glacial lakes of Connecticut. Glacial Lake Norfolk was an ice-dammed lake formed at about 15,500 years ago and a later lake formed just to the north. Today Tobey Pond remains in the bounds of Glacial Lake Norfolk.

The uncovering of the landscape from tens of thousands of years of glacial cover, revealed one full of erosional and depositional geomorphic features. Erosional features include contemporary lakes, valleys, and smoothed-over mountains. A particular erosional feature, called a roche moutonnée is named for the wigs worn by French elites in the 1700s. The landform has a long gentle approach on upstream side created by the ice smoothing it (remember the sandpaper) and then a steep cliff on the downstream side created by ice plucking bedrock as it rode over. Since ice moved north to south in New England, we find many south-facing steep slopes and cliffs in Connecticut and Great Mountain Forest. The steep slopes above Wampee Pond, Wapato Pond, and Crissey Pond are all such features. The depression below (the ponds or originally wetlands) were formed from the increased pressure of downward flowing ice below the steep cliff. Such a pond is called a tarn.

Depositional landforms are created when a glacier deposits material. Long Island, NY is a terminal moraine deposit from the southern extent of the Laurentide Ice Sheet. Eskers, long meandering piles of material carried as a streambed flows within a glacier are created after the ice melts away, and a snake-like relief of unconsolidated sediments remains. Eskers occur near Tobey Pond. Glacial till consists of unsorted sands, gravel and boulders left as a glacier melted. Most of GMF is covered in glacial till. It's hard not to find boulders and stones on the ground in Great Mountain Forest.

The map on page 5 (please forgive its lack of sharpness) shows the boundary of Great Mountain Forest on a USGS map of glacial geology by Stone et al. (2005). Northeast of GMF, including the area of Tobey Pond and Tobey Bog is the light blue Glacial Lake Norfolk. Within that, red dashed lines show moraines from glacial deposition. The black arrows

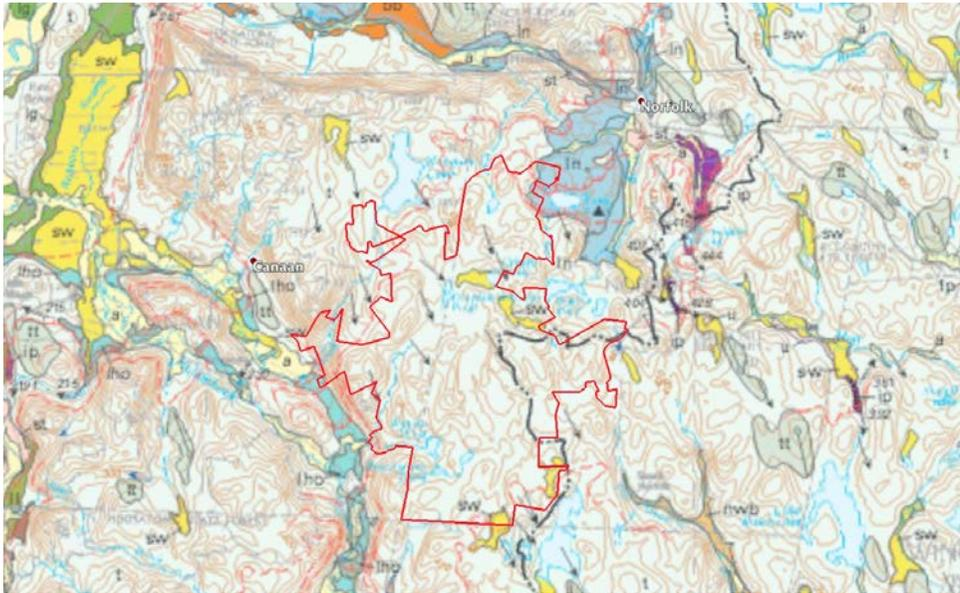

Great Mountain Forest boundary (in red) on Glacial Geology Map (Stone et. al. 2005). Villages of Norfolk and Canaan shown.

indicate the direction of travel of the ice, which at GMF was south to southeast. Yellow shows postglacial swamps we see today. Note a small piece of Glacial Lake Hollenbeck on the west edge of GMF. This, today, is the site of the Chestnut Plantation. The majority of GMF has no color on the map, which indicates glacial till, the random unsorted deposit of sand, silt, gravel, and boulders. A walk in GMF reveals this. It's typical of rocky uplands in postglacial environments. The more interesting depositional features (lakebeds, moraines, etc.,) tend to occur in valleys.

### GMF IN CONTEXT

Finally, the contemporary landscape is revealed showing Great Mountain Forest's topographic position. The specific topography - the uplands, valleys, and rivers, is driven by the geologic story discussed above, and the final shaping by repeated glaciations. The biologic landscape – the flora and fauna – responds to this. For example, rattlesnakes find habitat on the steep south-facing, warm rocky slopes of a roche moutenee. And red spruce trees inhabit the low, cool, moist bottomlands. In time, culture followed these cues with settlement occurring primarily in the rich marble valley soils of the Stockbridge formation and later, and only temporarily, in

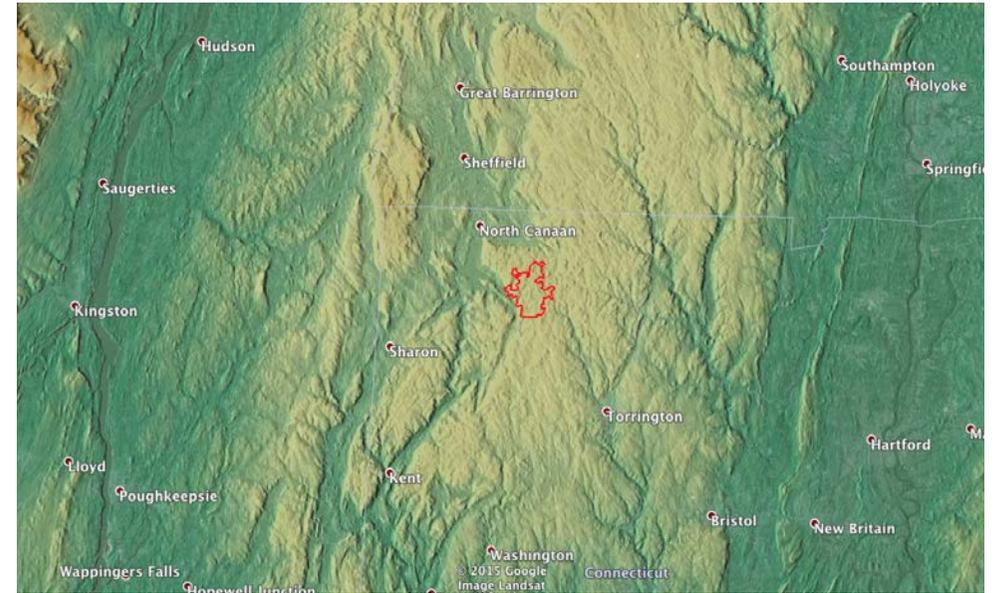

Topographic relief and position of Great Mountain Forest (red outline) in the tri-state area between the Hudson and Connecticut Rivers. Terms described in the text.

the cool, acidic, poor upland regions of GMF and elsewhere.

A few additional aspects of the physical landscape worth mentioning specifically:

### Geographic Terminology

The shaded relief map provides labels of the upland areas of inland southern New England. The Taconic Mountains occur mainly along the borders of New York and Vermont, Massachusetts and Connecticut. As noted previously, though the Canaan Mountain Schist of GMF was an overthrust of the Taconic Orogeny, it is not considered a part of those mountains. The Housatonic Valley defines the Taconic's eastern edge. (Recall valleys erode easier and they show a weakness where different physical provinces meet.) The Berkshires include the mountains and hills of western Massachusetts, east of the Taconic Mountains. They are geologically a part of the Green Mountains of Vermont; the Berkshires is a cultural term for the same physical feature. Similarly, the Litchfield Hills is a cultural name for the same geologic feature occurring in northwest Connecticut.

## Elevation

Great Mountain Forest averages approximately 1500 feet (450 meters) in elevation. The highest ridges reach over 1750 feet (530 meters), while the lowest point occurs at 730 feet (220 meters) in the Hollenbeck Valley at the American chestnut plantation.

## Hydrologic setting

Great Mountain Forest sits in a high upland of the Housatonic River watershed. It sits on a watershed divide: the north section drains northeast into Spaulding Brook, which feeds the Blackberry River, and on to the Housatonic; the western extent drains into Wagnum Brook, through GMF, down to the Hollenbeck River Valley, joining the Housatonic River near Robbins Swamp; areas in the southwest of GMF drain through small tributaries to the Hollenbeck River; and areas in the southeast drain through small streams and reservoirs and eventually into the Naugatuck River. The Naugatuck joins the Housatonic almost 50 miles from GMF, just 10 miles from Long Island Sound.

## Soils

The study of soil is perhaps the least appreciated component of ecosystem science. Soil is formed by the interactions of five components: parent material; climate; organisms; topography; and time. The soils of New England are largely driven by glacial activity. Most of GMF contains glacial till. A few areas contain swamp soils or lacustrine glacial lakebed sediments. In terms of plant productivity, generally, deeper, mesic, nutrient rich soils are best, for both forests and human uses. GMF does not contain many of these soils, and for that reason agriculture was short-lived, and today forest dominates.

## Places to observe geologic features in Great Mountain Forest

Geology can be observed anywhere in Great Mountain Forest. Listed in the Geologic Special Places are sites to find specific bedrock types, glacial features, and locations where the physical landscape (geologic and geomorphic) meets the cultural one.

## RESOURCES

*Skehan, James. 2008. Roadside Geology of Connecticut and Rhode Island.*

*Mountain Press Publishing. Long Island Sound Resources Center. 2011. The Grain of the Land. Retrieved from: <http://www.lisrc.uconn.edu/lisrc/geology.asp?p2=History&p3=glhct>*

*Stone, Janet, et al. 2005. Quaternary geologic map of Connecticut and Long Island Sound basin. United States Geological Survey and Connecticut Department of Environmental Protection, Geological and Natural History Survey. <http://pubs.usgs.gov/sim/2005/2784/>*



The eastern deciduous forest of North America describes a complex of forest types that covers the eastern third of the United States, southeastern Canada, and northeastern Mexico. It stretches north to south along the Atlantic coast from Maine to Florida, and extends in the west all the way from Minnesota down to central Texas. Ample precipitation throughout this region, combined with high variability in topography, soil type, and climate, make it one of the most diverse assemblages of temperate forests found anywhere in the world. Classifying distinct forest types within this region is difficult, as the ranges of individual species often overlap and grade into one another, and communities can exist in patchy formations according to landscape level shifts in slope, aspect, and microclimate. In general, moving northward along the Atlantic coast, forest assemblages shift from the fire-prone pine forests of the southeast up into oak-pine and oak-hickory communities. From there the forest changes to the northern hardwood communities which encompass most of New England, and finally the boreal coniferous forest which covers the bulk of Canada.

Great Mountain Forest sits at the nexus of several of these forest communities. Many areas are dominated by species of oak and hickory, particularly at high elevations and on dry, southern-facing aspects. The bulk of the forest, however, is composed primarily of eastern hemlock (*Tsuga canadensis*), American beech (*Fagus grandifolia*), sugar maple (*Acer saccharum*), and birches (*Betula* spp.), which are the typical species of the northern hardwood forest that extends from Massachusetts up through southern Quebec. There are also a few notable species outliers. In the area of the Forest with the lowest elevation—a small pocket in the southeast corner

## DEVELOPMENT OF THE EASTERN DECIDUOUS FOREST

A BRIEF HISTORY



**View over the GMF canopy. Since it sits at the nexus of several distinct forest types, GMF is host to a wide diversity of plant species.**

along Under Mountain road—there are tulip trees (*Liriodendron tulipifera*) and sassafras (*Sassafras albidum*), species common in the mixed mesophytic (moist) Central Appalachia and southern hardwood forests, but which are rare as far north as Litchfield county. Similarly, but oppositely, certain bogs and swamps in the Forest contain healthy communities of black and red spruce (*Picea mariana*, *Picea rubens*), which are closely associated with boreal habitats, and are certainly towards the southernmost extent of their range here in Connecticut. The convergence and intermixing of these forest types across one intact land unit makes Great Mountain Forest a fascinating place to study plant community dynamics.

The current character of the eastern forests has been shaped by a number of powerful forces across different timescales. The activity of plate tectonics and dramatic fluctuations in climate across millions of years brought about the shape of the North American continent, and strongly influenced the evolutionary lineage that produced the tree species it contains. The freeze-thaw cycles of our current ice age have jumbled and mixed these species around the landscape for over two million years, appropriating them to their modern day ranges and combinations. The forests our generation knows are further fashioned by thousands of years of

human management, which continues to transform the landscape in radical ways. To understand the context of this relationship between people and the forest, it is first necessary to outline the major geologic and evolutionary events which have molded our shared existence.

## **GEOLOGIC TIMESCALE (350-2.4 MYA)**

In a sense, the origin of the eastern deciduous forest can be traced to the humble beginnings of the first forests of the world, which arose during the late Devonian around 350 million years ago (mya). These ancient woodlands looked very different from those we see today, composed mostly of giant lycopsids (clubmosses) and tree ferns that were well adapted to the increasingly hot and humid climate of the late Paleozoic. These plant groups would continue to dominate for several hundred million years until the rise of coniferous trees (gymnosperms) during the Triassic period. The woodland ferns, horsetails, and clubmosses that creep along the understory of modern temperate forests are miniature memories of their tree sized ancestors. Fossilized trunks of *Stigmaria* and *Lepidodendron*, (ancient clubmoss species) have been found that average 7 to 10 feet in diameter—far wider than any tree growing in eastern North America today.

By the beginning of the Permian period, all the major landmasses of the planet were fast converging towards one another. The Alleghenian orogeny was completed around 280 mya, when the ancient supercontinents Gondwana and Laurussia fused together to form the bulk of Pangea (literally, “all land” in ancient Greek). Pangea was so massive that the moist winds from the ocean could not reach its center. Heat given off from the interior helped raise global temperatures, melting glaciers around the South Pole. Forests, along with most land dwelling life forms in general, were confined to the relatively hospitable coastal regions. Conifers had been around since the late carboniferous (300 mya), but gained prominence in this harsher environment, possibly owing in part to their greater ability to cope with droughty conditions. By the first part of the Jurassic, some 190 mya, the forests of the world were dominated by ginkgos, giant cycads, and ancient needle leaved trees, radiating all along the coastal plains of the unified continent.

Flowering plants (angiosperms) first appeared around 125 mya, during the beginning of the Cretaceous. By this point, Pangea had broken into smaller continents again. Laurasia separated from Gondwanaland, and itself split into more or less familiar forms of the northernmost

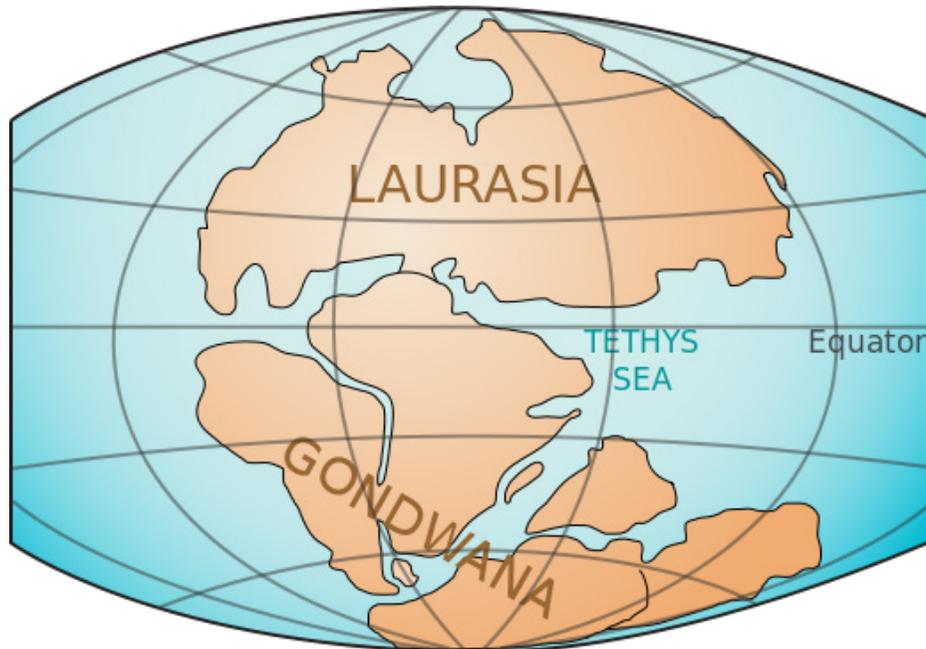

Map showing the relative positions of Laurasia and Gondwana during the breakup of Pangea, around 200 mya. Source: User:LennyWikidata [CC BY 3.0 (<http://creativecommons.org/licenses/by/3.0/>)], via Wikimedia Commons

continents: North America, Europe, and Central Asia. Together these regions constitute the Holarctic (or Boreal) floristic kingdom, which is further broken into the Palearctic (Old World) and the Nearctic (New World). Because they were united for a longer period before drifting apart and had episodic instances of contact thereafter, the forest flora of these regions are markedly similar. Whether in New England, Central Europe, or the plains of China, today's northern latitude temperate forests all contain related species of trees, shrubs, and herbs from the same families, such as the birches (*Betulaceae*), oaks, beeches, and chestnuts (*Fagaceae*), cherries and roses (*Rosaceae*), buttercups (*Ranunculaceae*), mustards (*Brassicaceae*), saxifrages (*Saxifragaceae*), and pines, firs, spruces, and larches (*Pinaceae*) extending into the circumboreal regions farther north.

Throughout most of the Cretaceous until about 75 mya, eastern North America was an island, still separated from the modern day Pacific coast region by the broad and shallow Bearpaw sea. An evergreen tropical forest of early flowering trees, including the magnolias, had gained prominence, growing larger and moving northward to form mixtures with early progenitors of ancient coniferous species such as the monkey puzzle

tree (*Araucaria araucana*) and the dawn redwood (*Metasequoia glyptostroboides*) that were then dominant canopy trees. Early relatives of the pines (*Pinus* spp.) were present at this time, but existed mostly as small understory shrubs. The tropical climate of this period persisted well into the Paleogene, when a major cooling trend began around 33 mya. The forests shifted to a more temperate type, dominated by groups of deciduous broadleaved tree species that would look fairly similar to what we have today, with tulip-trees (*Liriodendron tulipifera*), various legume (*Fabaceae*) species, and oaks (*Quercus* spp.) becoming prominent in forest assemblages.

### ENTERING AN ICE AGE (2.4 MYA - PRESENT)

Around 2.4 mya, the world entered a new ice age: an ongoing series of freeze-thaw cycles with corresponding periods of glaciation and interglaciation. As the Earth orbits the sun, slight shifts in the eccentricity, angle of tilt, and axis of rotation—known as Milankovitch Cycles—set long alternating phases of global heating and cooling into motion. Available geologic evidence collected from deep ocean sediments suggests that Earth has gone through at least 17 of these cooling/heating cycles (so far). In the eastern United States and Canada, tree species respond to these climatic fluctuations by shifting their range north or south in step with the movement of glaciers extending from the far north.

The last such cooling event began 35,000 years ago, and reached its peak about 18,000 years ago. At its glacial maximum, the Laurentide ice sheet covered 13.4 million square kilometers of land, and in the eastern United States, extended far enough south to cover almost all of Connecticut (including Great Mountain Forest). Forest distributions changed accordingly. Directly to the south of the glacier was a band of tundra that stretched across Long Island (itself a terminal moraine created by the ice) westward past the Appalachians. Below that was a large swath of spruce forest (*Picea*), which mixed with a collection of cold-hardy pines in today's Georgia and the Carolinas. Virtually all the temperate hardwood species so dominant in today's eastern forest were relegated to a tiny refuge in the southern half of the Florida peninsula. It is interesting to note that the north-south orientation of the Appalachian mountain chain permits the passage of tree species to and from glacial refugia. In Europe, temperate tree species migrating south from the expanding glacier ran up against the Alps, which run east-west, and many were trapped and extirpated. For this reason, and to this day, the forests of the eastern United States have a much

### ROGERS LAKE - TREE POLLEN PERCENTAGES

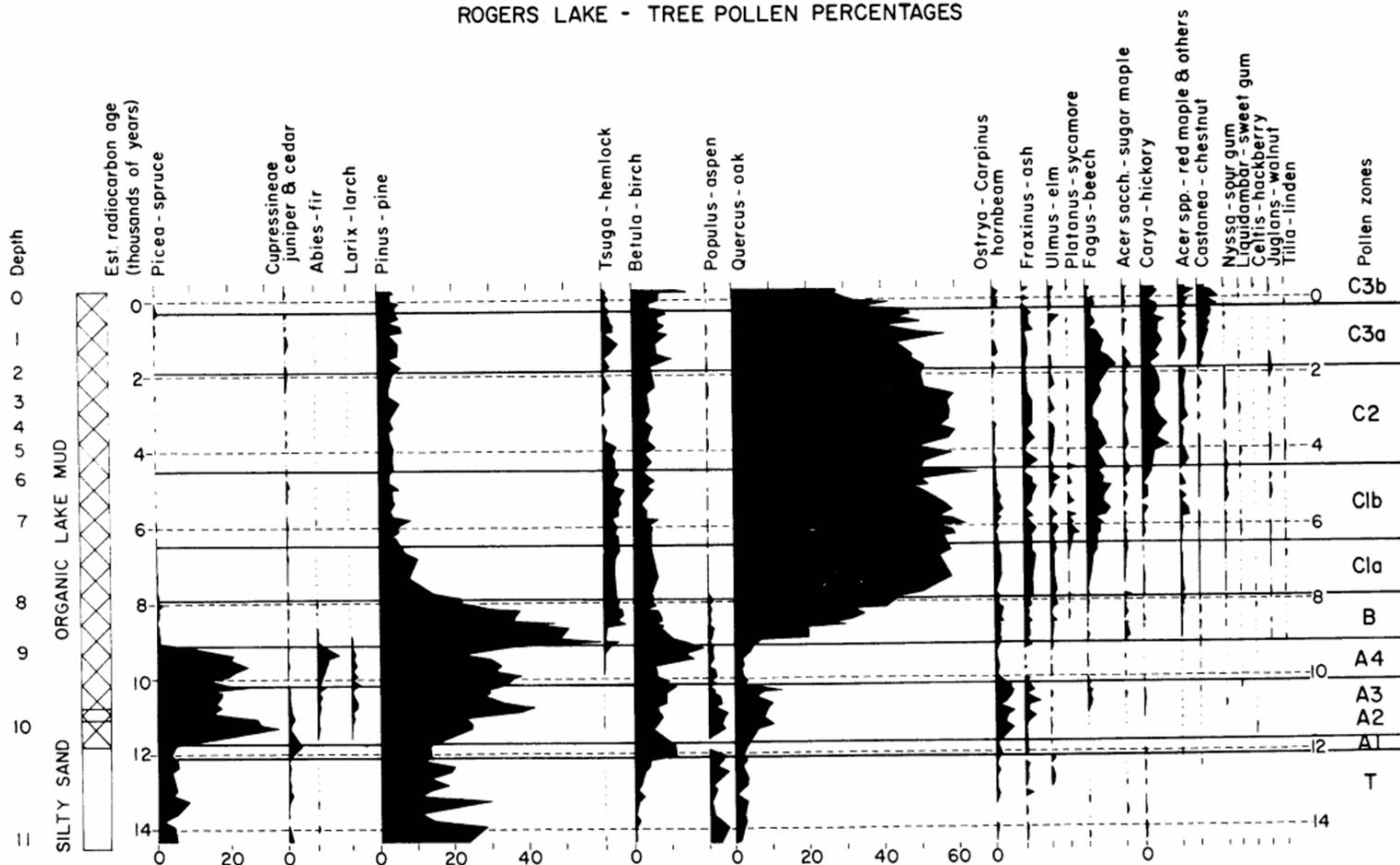

Graph showing relative abundances of tree species pollen collected from cores of increasing depth, and hence earlier deposition. Taken together, the data demonstrate a transition from spruce to oak forest over the past 12,000 years (from Davis 1969).

higher diversity of tree species than the forests of Western Europe.

By about 15,000 years ago, the climate warmed again, and the Laurentide ice sheet melted northwards. In its wake the glacier created “kettlepot” lakes—areas where meltwater accumulated in depressions formed by buried ice melting under sediment. By extracting sediment cores from the bottoms of these lakes and aging them using radiocarbon dating methods, paleoecologists can identify the species of pollen that accumulated from ancient trees. This information is used to reconstruct the historic forest compositions through time since the retreat of the glacier.

In a study from southern Connecticut, Davis (1969) analyzed pollen

deposition in lake sediments, spanning a 14,000-year period up to the present day. The fossilized grains tell the story of tree species migration northward over time as the climate warmed and stabilized. From 14,000 to 12,000 years ago, Connecticut and much of southern New England was a tundra landscape. The pollen grains from this period are mostly herbaceous species that we currently associate with an Arctic flora. By 10,000 years ago, spruce and fir had moved in to become the prominent vegetation assemblage, with small populations of oak, white pine, hornbeam, alder, and ash. The less cold-hardy white pine was the dominant species by around 8,000 years ago, accounting for 50% of the total pollen

accumulation. The boreal spruce, fir, and larch species decreased rapidly during this period, being outcompeted by the more temperate adapted tree species. They continued migrating north, closer to their modern day distribution. Following a heating and drying trend that lasted until about 6,000 years ago, oak species moved in to become more dominant across much of the Connecticut canopy, which is still the case today.

Forests and glaciers have been dancing north and south across the whole of eastern North America in this fashion for millennia. Tree species respond individualistically to shifts in climate as opposed to rigidly defined obligate communities, each according to its own growth rate, seed dispersal mechanism, and amplitude for tolerating ecological stressors. Each cooling and thawing sequence results in novel forest assemblages for which there are no equivalent modern counterparts—a phenomenon known as the “no-analog problem” (Brubaker 1988). For example, although the immediate post-glacial environment of Connecticut did resemble today’s arctic tundra with its herbaceous plant distribution, pollen studies show evidence of some scattered oak individuals, which are unknown in today’s arctic communities. Oaks as a general group took much longer to move northward because of their seed dispersal strategy. As a masting species, oaks drop large quantities of nutrient-rich nuts to satiate their dispersal agents (mostly squirrels, today) and have enough left over to germinate. The wind dispersed pines, however, are able to send their seeds much greater distances and in higher quantities to colonize newly habitable landscapes, which helps explain their dominance in the region several thousand years before oaks. In short, though paleobotanical data can provide useful insight when trying to determine how forest species and communities will respond to future shifts in climate, ultimately the novel conditions and non-predictable responses of species to changes in temperature and precipitation make it impossible to determine for certain.

## HUMAN RELATIONSHIPS (13,500 YA - PRESENT & FUTURE)

In addition to shifts in forest composition caused by geologic, evolutionary, and climatic agents, further changes wrought by anthropogenic means have interacted with these forces to shape the eastern deciduous forest as it exists today. For as long as the most recent glaciation has receded, there have been people here, manipulating the environment. American Indians have for thousands of years set fires in the forests, primarily in floodplain areas or along streams where conditions

were most suitable for habitation. In some cases, entire tracts of the forest would be burned away completely, to create open grounds for agriculture or new settlements. When they moved on from these areas to find new sites, forests returned to the abandoned land, creating a patchwork of stand compositions and age classes. More often however, people would set lower intensity ground fires, which consumed all ground level fuel and vegetation but left the canopy trees mostly intact. This created more open, park-like forests, and promoted the growth of medicinal herbs and fire resistant, nut producing trees. It also created better habitat for wildlife, and made hunting these animals easier. It is thought that entire unique ecosystems, such as the grassy oak savannahs of the Midwest, were completely engineered and maintained by Native American fire usage.

The arrival of Europeans brought another dramatic restructuring of forests. The original colonies were founded, in part, to satisfy England’s demand for high quality timber, particularly large old growth eastern white pine (*Pinus strobus*) that could be fashioned into ship masts for use in its long-running naval wars. Forests were decimated in a more or less systematic fashion heading westward, to feed the hungry needs of the new nation. Logging accelerated in pace over time to keep up with new demands for construction timber, and fuel for forges and early wood-powered trains. Within a few hundred years, virtually all the old growth trees in the east had been felled. Besides being much younger and denser, the regenerating forests tended to have vastly different species compositions, favoring early pioneer species like birches and pin cherries over shade tolerant, later successional species like sugar maple, American beech, and hemlock.

European settlers also existed under a land tenure system that promoted permanent clearing and “development” of private and publically owned property. Forested land became more and more fragmented as agriculture and new settlements proliferated across the landscape. Remaining forest stands had smaller cores and a greater proportion of edge habitat, which again promoted different guilds of plant and animal species. In New England, large portions of the landscape have filled back in with forest as agriculture moved westward and fields were systematically abandoned. These have been chipped away at since the 1970s with the sprawl of suburbia and other development projects. History seems to repeat itself, yet it seems unlikely that these high value properties with extensive rolling lawns will ever be abandoned the same way that the poor quality farmland was.

Under an increasingly globalized economy where goods are

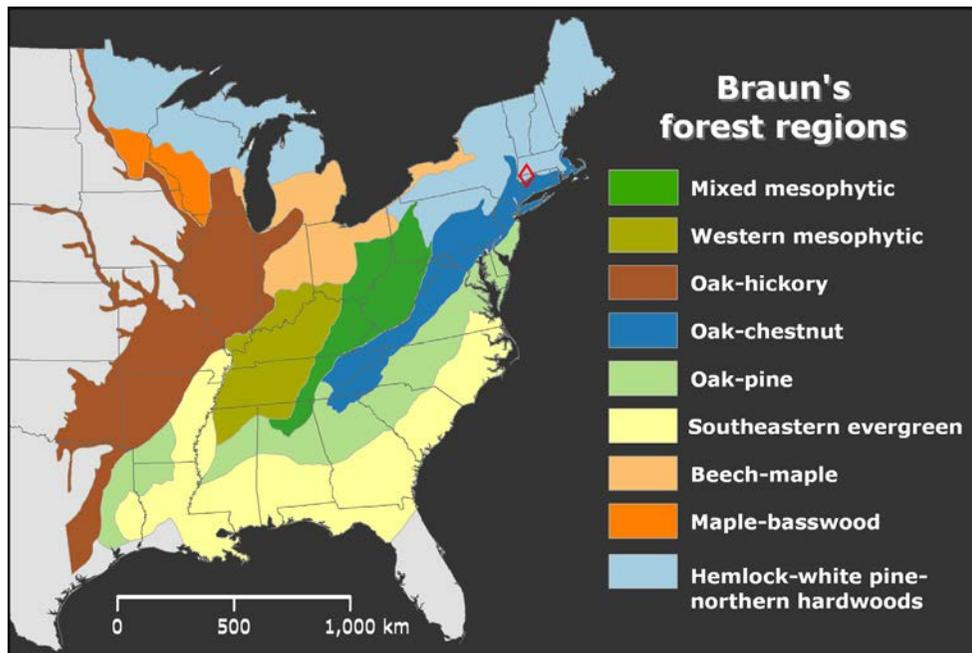

Maps of eastern US forest regions, by Lucy Braun in 1950 (top) and 2006 revision by James Dyer (bottom). The absence of American chestnut as a dominant community type has largely taken over by oaks and hickories. Great Mountain Forest (red diamond) sits at a critical transition zone between the Appalachian forest and northern hardwoods. Hardwoods (indicated by the red stars).

being shipped around the country in greater quantities and faster speeds than the world has ever seen, a whole suite of invasive plant and animal species have been introduced to the North American continent, sometimes with important consequences for the structure and health of eastern forests. Some of these are airborne fungal pathogens or insects that have the capacity to parasitize and make entire tree species functionally extinct. When the chestnut blight (*Cryphonectria parasitica*) was accidentally introduced to New York in 1904, it quickly spread throughout Appalachia and within decades exterminated virtually all American chestnut (*Castanea dentata*) within its natural range, destroying an estimated 4 billion trees. This in turn led to a restructuring of forest communities where the species was prevalent, as species with similar ecologies, such as the oaks and hickories, moved in to fill the void that the dead trees had left behind. In other instances, the invasive species are plants themselves that compete vigorously for growing space with the native vegetation. Species such as Japanese barberry (*Berberis thunbergii*), Tartarican honeysuckle (*Lonicera tartarica*), and Asiatic bittersweet (*Symphoricarpos orbiculatus*) can quickly cover large swaths of land, inhibiting the natural regeneration of native tree seedlings. These species are of special concern to foresters who rely on natural seed sources to regenerate forestland following a harvest.

In addition to the preceding categories of anthropogenic landscape transformation, the future of the eastern deciduous forest is further complicated by the acceleration of human induced climate change. The rapid rise in temperature is expected to result in a dramatic shift in species composition and distribution as trees respond to new, possibly novel, site conditions. Knowing exactly what will happen is impossible, given the no-analog problem of forest assemblages through time, but it is possible to make predictions based on the observed physiological characteristics of individual species. Pioneering research at GMF led by Charles Canham and Stephen Pacala (Pacala et al. 1993, Pacala et al. 1996) led to the creation of a model to explain the process of forest growth. They collected the necessary data by performing rigorous measurements of all aspects of tree growth, down to minute details such as light dependent mortality and seed dispersal distances. Their SORTIE model is now the standard used around the world to predict shifts in the progression of forest development.

A 2003 report by the Pew Center on Global Climate Change (now Center for Climate and Energy Solutions) compiles the available information on the response of forests to climate change, based on different models of tree species migration patterns and atmospheric increase of

## CURRENT-PROJECTED FOREST TYPES

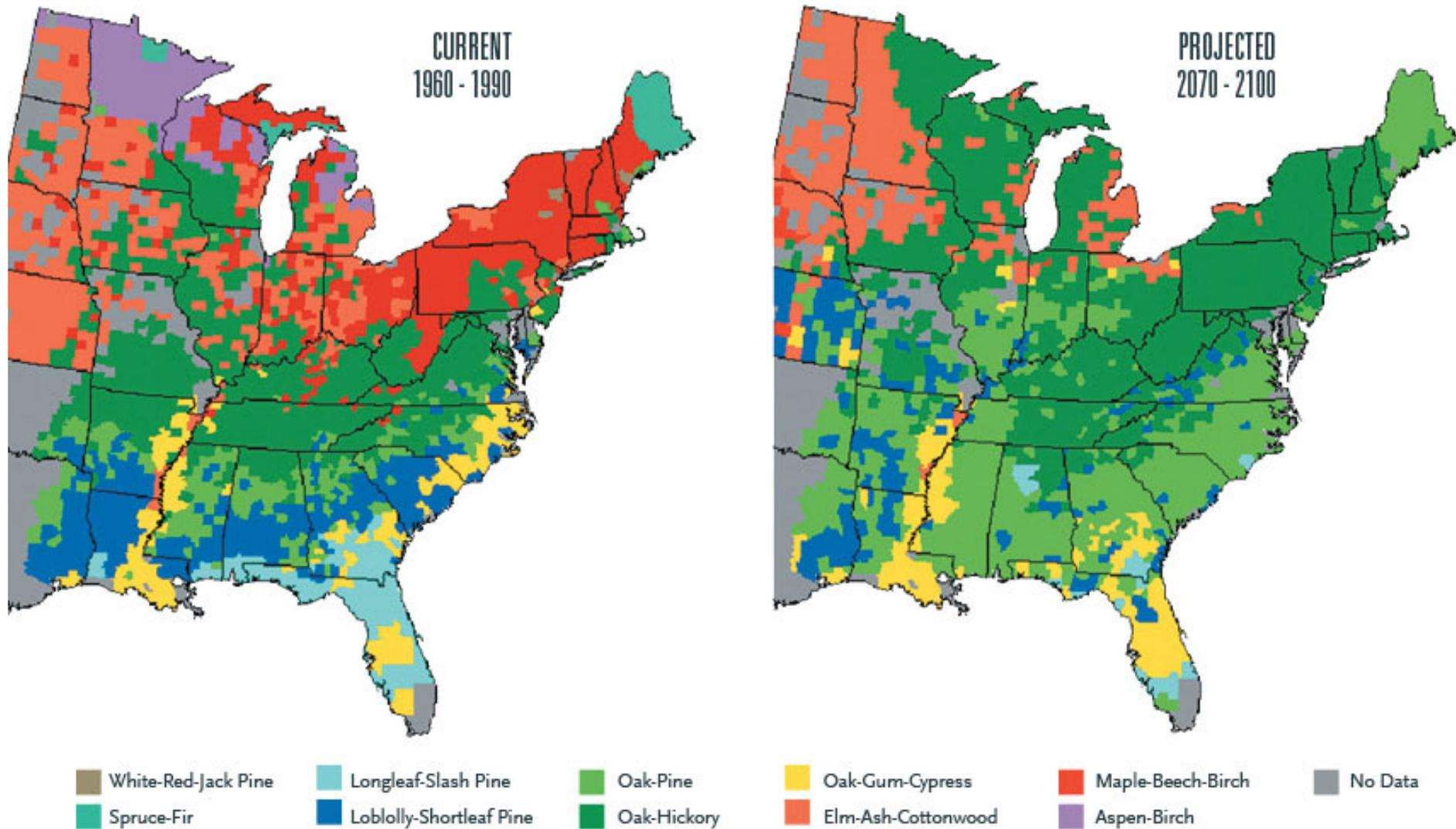

Maps showing projected future shifts in the range and distribution of different forest types in the eastern United States, based on climate change predictions and the known ecological amplitudes of tree species (Iverson et al. 1999). Note the predicted north-westerly migration of loblolly-shortleaf pine communities, and the near complete extirpation of northern hardwoods from New England and the Midwest (Shugert et al. 2003).

CO<sub>2</sub>. All, like the previous map based on the work of Iverson et al. (1999), suggest a general northward migration of forest communities. Most striking are the projected shift of southern loblolly/shortleaf pine ecosystems into the Central region, and the near complete replacement of Northern hardwoods by oak dominated systems in New England and the Midwest. In a sense, this community transition is a natural step in the ongoing freeze-thaw cycles of the current ice age. However, the heretofore unprecedented rapid pace of climate change wrought by human industrial practice may overwhelm certain tree species. Potentially vulnerable forest types, such as aging northern hardwoods and high elevation spruce-fir, may not be able to migrate quickly enough to respond to shifts in climate zones. The indefinite response of forests to climate change, compounded with the direct and indirect effects of other human enterprises, make the future character of the eastern deciduous forest hard to predict.

## RESOURCES

- Brubaker, Linda B. (1988) Vegetation History and Anticipating Future Vegetation Change. Pages 41-61 in J.K. Agee and D.R. Johnson, ed. Ecosystem Management for Parks and Wilderness. University of Washington Press, Seattle.*
- Davis, Margaret B. (1969) Climatic changes in southern Connecticut recorded by pollen deposition at Rogers Lake. Ecology 50: 409-422*
- Dixson, D., I. Jenkins, R. T. J. Moody, and A. Y. Zhuravlev. (2001) Atlas of Life on Earth. Barnes and Noble Books, New York.*
- Dyer, J.M. (2006) Revisiting the deciduous forests of eastern North America. Bioscience 56: 341-352*
- Iverson, Louis R., Anantha M. Prasad, Betsy J. Hale, and Elaine Kennedy Sutherland (1999) Atlas of Current and Future Distribution of Common Trees of the Eastern United States. United States Forest Service Northeastern Research Station, General Technical Report NE-265*
- Flannery, Tim (2001) The Eternal Frontier: An Ecological History of North America and its Peoples. Grove Press, New York.*
- Pacala, S.W., C.D. Canham, and J.A. Silander, Jr. (1993) Forest models defined by field measurements: I. The design of a northeastern forest simulator. Canadian Journal of Forest Research 23: 1980-1988*
- Pacala, S.W., C.D. Canham, J.A. Silander, Jr., and R.K. Kobe. (1996) Forest models defined by field measurements: II. Estimation, error, analysis, and dynamics. Ecological Monographs 66: 1-43.*
- Shugart, Herman, Roger Sedjo, and Brent Sohngen (2003) Forests & Global Climate Change: Potential Impacts on U.S. Forest Resources. Prepared for the Pew Center on Global Climate Change.*



# HUMAN HISTORY

OF THE GREAT MOUNTAIN FOREST REGION

## **CONNECTICUT'S NATIVE PEOPLES: 13,500 YEARS BEFORE THE PRESENT (YBP) - PRESENT**

Connecticut's human history began after the northward retreat of the Laurentian ice sheet.<sup>1</sup> By 13,500 ybp the southern extent of the glacier had moved completely into northern New England, leaving all of Connecticut an ice-free tundra. The low-growing vegetation in this environment supported a wide variety of mega-fauna, such as the American mastodon, giant ground sloth, and caribou, which sustained early native groups. People moved into southern New England from New York, either from the west, northwards from Long Island, or up from the mid-Atlantic region. The sheer amount of water taken up in the mass of the glaciers caused worldwide ocean levels to lower, so that Long Island Sound did not exist. There was contiguous land connecting Long Island with the southern Connecticut coast, which permitted easy access into the newly de-glaciated landscape (south of present day Long Island, the Connecticut coast extended an additional 60+ miles onto the Atlantic shelf). The Sound filled in later when ice sheet melting accelerated, but it is likely that archaeological evidence of habitation from the migration northwards into New England exists beneath the water there, awaiting discovery.

The earliest evidence of human habitation in the state is the Templeton site in Washington, Connecticut, about 30 miles south of Great Mountain Forest. The site is a temporary encampment that has been radiocarbon dated to around 10,200 ybp, and contains an assortment of

---

<sup>1</sup> Habitation likely began much earlier south of the mainland on the Atlantic shelf. Sacred origin stories of the Narragansett tribe tell that they were always here in southern New England, living south of the glacier.

chert, quartz and quartzite stone tools. They are suggestive of a society which relied on both hunting and the preparation of plant material for sustenance, and already possessed the ability to process wood to create a variety of useful implements.

From an ecological context, it is interesting to note the habitat types these early groups preferred. Unlike later Indian communities whose subsistence cycles generally located them along coastal lowland waterways and floodplains, evidence from all of the Paleo-Indian archaeological sites in Connecticut suggests that people from this time period lived in inland regions, and often at higher elevations. Acceleration of glacier melt caused water levels in river valleys to rise so rapidly that they didn't accumulate the sediments required for marsh formation or healthy streamside vegetation. This turbulent environment could not support the populations of many of the plant and animal species that were traditionally thought to be a key source of sustenance during this time period, and were likely avoided by early peoples for this reason. Over the succeeding millennia as the climate stabilized and ice melt slowed, population centers shifted towards coastal regions and large river valleys where the formation of salt marshes and rich riparian zones afforded new abundances of plant and animal life.

The climate warmed dramatically during the early Archaic Period from about 10,000-8900 ybp. Evidence from fossilized pollen cores suggests that a forest of white pine with oak and birch predominated over the spruce, larch, and fir, which could support more species of wildlife. The development of new technologies throughout the Archaic Period allowed greater utilization of newly available natural resources. Visitors to Great Mountain Forest today can visit the nearby Robbins Swamp, a glacial lake basin that was a major center of settlement during this period. The mosaic of forests and wetlands in this area along the Blackberry River would have been an ideal dwelling place—supporting important game animals such as moose, deer, black bears, and beavers, as well as important food plants such as cattails, Indian cucumber root, and bulrushes. One archaeological excavation within the swamp revealed the remains of an old workshop, where jasper for tool implements was extracted from quartzite rocks through a complex process of intense heating and hammering. There have been no artifacts discovered in Great Mountain Forest itself other than several scattered spear and arrow points and a marble stone that may have served as source material for tools (see Land Use 7: Dean Farm), but it is likely that people living in the Robbins Swamp area roamed there regularly as territory for hunting and plant foraging. As struggling European farmers



**Quartzite arrowhead found at Great Mountain Forest.**

would discover thousands of years later, the wavy topography and thin, rocky soils of the Forest region make it a very difficult place to make a living. However, a detailed archaeological study of Great Mountain Forest has yet to be conducted, which could well reveal evidence of more permanent settlements.

The trend of heating and drying continued into the middle Archaic Period between 8,000-6000 ybp, which increased the relative density of oak species in forest canopies. By 4,000 ybp, the climate had reached more or less current conditions, and promoted the northward migration and growth of new food plant species. Human populations began to migrate from dry uplands to river valleys, where they developed new Neville points, axes, and gouging tools to make dugout canoes. These were usually made by carving out trunks of rot resistant chestnut trees, as opposed to the lighter birch bark canoes of northern New England Indian groups. Broader fishing capabilities and an increasingly favorable climate that promoted new food plant species—particularly with the development of salt marshes in New England, some 2500 ybp—led to the refined development of annual subsistence rounds. These were regular cycles of

food resource gathering activities that followed their availability across seasons and landscapes. Each spring there are new abundances of edible leafy plants to gather, such as wild leeks, thistles, violets, and watercress. During the summer new plants become available, as well as tubers and wild fruit. By fall, various seeds, nuts, and acorns have developed, which could be stored for use during the coming winter. Some resources, such as fresh and saltwater fish, could be gathered during all three of these seasons, while other animals, such as deer and hibernating bear, could be hunted all year round. Communities would move fluidly into larger and smaller groups across the landscape as resources shifted in availability. In this way, important kinship connections were maintained and strengthened within the larger units of tribes and confederacies.

Maize cultivation, believed to have originated some 9,000 years ago in the Tehuacan Valley, Mexico, was adopted only recently in the Connecticut region—some 950 ybp during the late Woodland Period. The non-agricultural tribes of northern Maine continued to depend heavily on hunting to get them through the cold parts of the year. However, in the south, the ability to grow food that could be stored through the winter months made people less reliant on other forms of sustenance during times of scarcity. This allowed for much greater population densities in the Connecticut region, as suggested by the abundance of archaeological sites located along the Atlantic coastline and the Connecticut River.

Communities living during the Woodland Period also utilized fire regularly as a means of creating more favorable landscapes for subsistence activities. When it was time to clear new fields for agriculture, women piled fuel at the bases of all the live trees in an area and set them alight. The small fires were hot enough to burn through the bark and kill standing canopy trees, even very large ones. These would fall over in successive years, where they could be reduced to cinders by repeated burnings. In this way, large areas could be opened up for spring planting, in nutrient heavy soil enriched by the ashes of the incinerated forest. Such fields could be farmed intensively for 8-10 years while sustaining good yields, with prolonged fertility provided by the nutrient fixing bean crops that were planted among the squash and corn. After that point, the community would move and continue the land use sequence elsewhere, leaving the abandoned field to return slowly to forest. Through patterns of mobility with periods of intensive land use, the ecological integrity of the overall landscape was sustained in a patchwork of different successional stages.

Lower intensity brush fires were also used on a yearly or bi-yearly

basis to clear out the shrub layer while leaving the tree canopy intact. This created open, park-like forests, and promoted the growth of a rich herbaceous layer. Among these were many plants useful to people as sources of food and medicine, but they also served as important forage for grazing mammals such as deer, which themselves were easier to hunt in the open environment. Besides altering the forest structure, this burning activity also altered the composition of the canopy in areas where it was practiced regularly, promoting species more tolerant to fire. These tended to be thick barked hardwoods that are better insulated against high temperatures, such as oaks, hickories and chestnuts. These are all mast species that produce high quantities of protein and lipid-rich nuts, and selecting for them meant greater abundances of this important food resource.

When European travelers first explored the New England region, they thus found a landscape that was not pristine but in fact already deeply modified by people in a number of sophisticated ways. Explorers like Giovanni de Verrazano—whose 1524 journey from the New York harbor along the southern Long Island shoreline into Narragansett Bay is the first documented European voyage in the Long Island Sound region—wrote of expansive, open forests and broad areas of sparse vegetation all along the coastline. The first permanent settlement in the region was established by Henry Hudson in 1609, which was followed several years later by the opening of a trading post for the Dutch East India Trading Company along the Hudson River. Subsequent Dutch settlement on Manhattan Island and Long Island opened the Connecticut river-ways to trading with local Indian communities.

All the tribes from the Connecticut region belong to the broader Algonquian language group, whose territory extended from the Powhatan on the Chesapeake, to the Innus in Quebec and Labrador, and the Anishenabe around the Great Lakes. In Connecticut, these lands were arranged into various distinct tribal territories, which all shared general language and lifestyle practices, but differed regionally with regard to spoken dialect and political structure. Litchfield County, where Great Mountain Forest is located, comprised some or all of the tribal homelands of the Mahicans, Tunxis, Weantinock, and Pootatuck peoples. Adjacent Paugussett homelands extended to present Waterbury, in New Haven County.

Initially, relations between Connecticut Indians and early European traders were largely positive. Brisk trade networks developed between these two groups, the Indians providing various animal furs in exchange for iron

tools and bolts of cloth. For a brief time, indigenous societies adapted to incorporate new elements bartered in trade to enhance their traditional lifestyles and cycles of subsistence.

Before long, however, Indians throughout New England were overwhelmed by the combined effects of land encroachment, resource depletion, disease introduction, and forcible expulsion by the European-Americans. Pressure from over-hunting and the fur trade caused the extirpation of many important animals from southern New England by the beginning of the 18th century, including the beaver, turkey, white tailed deer, elk, black bear, and lynx. Europeans in Connecticut spread westward quickly following the establishment of the first formal settlement in the state at Windsor in 1633, which forced Indian communities to reconfigure into denser village structures. These were by new necessity increasingly sedentary, as opposed to the fluid, mobile societies of previous generations. The tribes of New England were further devastated by the introduction of infectious diseases, which were unknown in the region beforehand. It is thought that the initial migration into North America across the Bering Land Bridge, where people lived in frigid temperatures and widely dispersed communities, acted to functionally sterilize many human transmitted pathogens over the course of successive generations, with the result that they did not spread into the continent. Additionally, most infectious disease is created through a relationship with domesticated animals, and the Native peoples of this region crossed into North America before pastoral practices were established elsewhere in the world. As a consequence, the Indian populations of New England possessed no genetic immunity to many of the diseases brought in by the Europeans, which soon decimated Indian communities across the landscape. An epidemic that started in Massachusetts in 1616 (likely hepatitis, spread by French fishermen), soon spread westward across indigenous trade networks into the Connecticut region, decimating native populations. In 1634, a smallpox epidemic erupted in the Connecticut Valley and radiated in all directions, killing 90% of the Indians living near the new Windsor settlement alone. Small pox also spread throughout the Hudson Valley region in Mahican territory, and eastward into Great Mountain Forest region.

Indian communities were thus already in disarray when settlement in the Connecticut colony increased dramatically during the second half of the 17th century. Many Puritan pioneers regarded the epidemics as an act of providence; God was sweeping away the indigenous population to favor the enterprises of the chosen Christian people. In a number of

cases, their new settlements were founded directly upon Indian villages whose inhabitants had all died from disease. Larger swaths of entire tribal territories were obtained by technical trade agreements, using various means of trickery, lies, and threats to force the increasingly desperate Indian communities to sell their ancestral homelands. In 1640, the entire territory of the Tunxis, a large constituency in northern Connecticut just east of Great Mountain Forest region, was sold to English colonists by the sachem of a neighboring tribe. The legality of this act was contested by the Tunxis into the second half of the eighteenth century, but to no avail. By that time, the Mahicans to the west were contesting outright illegal settlement in the town of Sharon, located in Litchfield County, south of Great Mountain Forest. In spite of an aggressive petition filed by the Sharon Mahicans in 1742, they, like the Tunxis, were forced to abandon their lands and move westward.

Two large scale armed Anglo-Indian conflicts resulted in the further dispossession of Connecticut Indians' tribal homelands. The Pequot War was waged by the English in 1637, who accused the Pequots of harboring the murderer of the trader John Oldham, found dead the year before. The colonists were aided in their attacks by several native tribes, including the Narragansetts, Niantics, and Mohegans. After a year of armed skirmishes, the English and their allies attacked Mystic, the main village of the Pequots. They there killed hundreds of people and razed all standing buildings. The fleeing survivors were pursued westward, many later killed or enslaved, with a few who escaped to safety in the then sparsely settled northern reaches of the state. The Pequots who remained were finally granted a reservation in 1651, but their lands would be subsequently relocated and severely reduced over the next two hundred years.

King Philip's War, (1675-1676) was waged by the Wampanoag Indians and their allies against the colonists in Plymouth, after two men from the tribe were unjustly executed. Exasperated with colonial demands for allegiance and the continual encroachment on native lands, the Wampanoags under the leadership of Metacomet (Philip), joined by the Podunks, Nashaways, and later the Narragansetts, went to war on settlements in southeastern New England. The bloody and destructive conflict that followed over the course of a year highlights the often confusing and divergent relationships between native tribes and their varying responses to the ascension of colonial power. Some groups, notably the Mohawks of eastern New York, joined the colonialists in attacking Philip and the Wampanoags, possibly under the will and influence of then

governor Edmond Andros. The Mohegans of southern Connecticut also assisted in defeating Philip's rebellion. The Pequots, still severely reduced from their own war with the English fifty years earlier, attempted to remain neutral, hoping to be left in peace. Other neutral tribes, like the Nipmucks, were nonetheless threatened and attacked on multiple occasions by the English as a part of their backlash against the rebelling tribes of the region. The war ended in August of 1676 with the death of Philip, and a severe reduction of the organized tribal lands of the Wampanoag, Narragansett, Nipmuck, and Podunks. Many Indians captured during the conflict from these and other groups were consigned into slavery, either domestically or sold to plantations in Barbados. King Philip's war would be the last major Indian uprising in New England, ushering in a new era of accelerated land loss and de-legitimization of Indian sovereignty as the English colonists continued to multiply across the countryside.

After King Philip's War the history of Native people in New England is one of surface accommodation and adaptation, and determined maintenance of cultural beliefs and practices. This quiet resistance lasted through the eighteenth, nineteenth, and most of the twentieth centuries, as Native people held on to what land they could, until legal decisions in the 1980s gave tribes new recognition and control of land. The American Indian population in Connecticut today is around 11,000. Most of them belong to one of the five remaining, state recognized tribes: the Schaghticoke, Paucatuck Eastern Pequot, Mashantucket Pequot, Mohegan, and Golden Hill Paugussett, each with its own sovereign governing structure. These distinct cultures endured centuries of dislocation, discrimination, and brutal living conditions on marginal reservation lands. Native people in Connecticut continue to endure, as many challenges continue to this day.

During those centuries following King Philip's War, the character of the landscape was completely transformed from a functioning ecological system into a patchwork of European-American agriculture, settlement, and industry. From the middle 17th century onwards, the repeated exploitation and collapse of natural resources from colonial enterprise would be the primary narrative governing the ecosystems of Connecticut, the greater New England region, and beyond.

## THE SETTLEMENT OF LITCHFIELD COUNTY, CONNECTICUT (1719 - 1909)

Litchfield County was relatively late to be settled by Europeans, when compared with New Haven to the south and Windsor to the east, both of which had dense populations by the middle of the seventeenth century. For many years, it was known to early colonists only as part of the "Western Lands", which so far as they knew contained only scattered, undocumented settlements until the official founding of Litchfield in 1719. Early European colonists in the region found Mahican communities near the new settlements of Sharon, Kent, Salisbury, and Canaan. Many of these were refugees from other regions who had been forced from their original homelands. They would be similarly dispossessed of their homes in Litchfield County once settlement in the region accelerated. An increased demand for timber, which was growing scarce in southern Connecticut, fueled the initial upsurge of settlement in the Western Lands starting in the 1720s.

The Connecticut General Assembly approved and laid out the boundaries for the towns of Norfolk, Canaan, Goshen, Cornwall, and Kent in 1732. Proprietary shares in each of these were scheduled for sale by way of public auctions in 1737-1738. Canaan and Norfolk, the two towns that contain between them the entirety of the current expanse of Great Mountain Forest, were first settled in this way. Throughout the 1740s, initial populations in Canaan were concentrated in fertile areas to the north by the Blackberry River, as well as current day Falls Village, with little to no initial activity in Great Mountain Forest itself. In Norfolk, it took until 1754 to sell all the rights to property shares of the town, and even then only after multiple failed auctions and the reduction of the minimum bid to \$20 per unit. The only ("legal") inhabitant in Norfolk until that point was a man named Cornelius Brown, who later built the first sawmill in the village. Once the rights of each town were bought, the proprietors proceeded to collectively divide the land into lots of between 50 and 210 acres for settlement, depending on the relative quality of each holding. In Norfolk, an additional 98 acres containing high value white pine were split among each of the proprietors, in addition to their existing holdings.

It is important to note the scale of the human timeframe in this section. Virtually all the intensive Euro-American land use history that occurred in Great Mountain Forest—from initial settlement to the acquisition of the first GMF properties by Starling W. Childs and Frederick Walcott in 1909—took place in the span of about 150 years. During that

brief window of time, dramatic changes to the landscape were wrought, following patterns of resource use and abandonment similar to prior regions of settlement, but at a far more rapid pace.

The first order of business for owners of these new land holdings was to clear large patches of existing forest, primarily to open land for pasture or agriculture. Evidence from early written accounts of the region, proprietor surveys, and existing biological legacies suggest that the forest of that time was fairly continuous, covering most of the landscape in a patchwork of climax and mid-successional elements. Clearing land holdings to create shelter and acreage for subsistence farming was an arduous task. It required the girdling of standing trees and repeated burnings to eliminate the stumps and standing snags, similar to the agricultural practices of the American Indians. Some of the timber would be used for local use, but demand during the earliest period of settlement was so low that in general, burning was the preferred practice.

Though the original arrangement of land holdings was designed with agriculture in mind, it quickly became apparent that the landscape was generally ill-suited for growing crops, with the exception of certain fertile patches in Canaan and Salisbury. By late in the eighteenth century, many farms were converting some or all of their land to raising sheep, or cows for dairying operations. These markets were profitable ventures in their day; populations swelled in urban areas along the Eastern Seaboard as society grew more industrialized, creating demand for specialty products that did not exist during earlier waves of New England settlement. This shift would of course come with special consequences for the surrounding forest environment. In some cases, the animals were pastured on former agricultural fields, while in others, animals were set loose in previously unused woodlots where they slowly opened up the canopy by eating and trampling the regenerating trees, and girdling or uprooting pole sized ones. In this way, large tracts of hitherto undisturbed forests would be functionally eliminated by the dawn of the 1800s.

As the towns and farms of Litchfield County grew more industrialized, timber usage gradually transitioned from subsistence purposes to various domestic and export markets. The number of sawmills in the region grew in number as populations swelled throughout Litchfield county. Between 1756 and 1830, the population of Canaan more than doubled from 1,100 to 2,301. The increase during this period was even more striking in Norfolk—from only 84 to 1,485. Sawmill production became more profitable as demand went up for domestic timber to build

new houses. Later, more specialized markets developed to create cheese boxes for expanding dairy enterprises, and hemlock bark for use in tanning sheep hides. A number of the early “up and down” sawmills operated in the current day Great Mountain Forest, such as the one built by Elisha Mansfield in 1806, along Meekertown brook. Steam engine powered mills and circular saws, both of which became more common later in the nineteenth century, dramatically increased the capacity for daily lumber production, even as the number of sawmills in Canaan and Norfolk decreased starting in the 1860s.

Exhibiting behavior similar to dam building beavers (see Natural Communities 10: Beaver Ponds), settlers held to a systematic hierarchy of preferred tree species, shifting harvest priorities only once the more favored species was exhausted. Old growth white pine was always the first to be cut for timber, particularly for use in house framing and flooring in the growing settlements. Never particularly abundant in the pre-colonial forest, timber-quality white pine was virtually eliminated from the forests of Litchfield County by the beginning of the 1800s. Clapboards made from oak species were also common lumber material, used in building construction wherever white pine did not exist. As nearby old growth forests continued to shrink in the region, colonists eventually turned to hemlock as a major source of timber, in spite of its lower quality and the tendency for older trees to contain unworkable defects.

Aside from timber, many tree species in Litchfield County were felled to create specialty products for export markets, such as sugar maples to make rifle stocks, white ash for canoe paddles, and various species for turned wooden bowls. Perhaps most importantly for the region, a booming dairy industry necessitated the mass production of boxes and circular casks for the shipment of cheese and butter products to urban markets to the south and east. This economy was strongest in Goshen, which was already producing 400,000 pounds of cheese per year by the beginning of the 19th century. Though not quite as industrious in terms of outright production, Norfolk still boasted a lively pastoral economy with over 2,000 heads of dairy cattle distributed among farmers there by the 1820s. It was common during this period for sawmills in the region to have auxiliary cheese box shops, exclusively for their manufacture. When the Erie Canal was officially opened in 1825, it allowed for easy access across the Appalachian Mountains between coastal cities and the Midwest. New England farmers were soon unable to compete with the increased settlement and production in the western lands, particularly in Wisconsin and western New York state.



Cream Hill in Cornwall CT, at the height of dairying operations. Note the landscape, almost completely denuded of tree cover.

As a result, dairy product output in Litchfield County declined steadily through the early 20th century.

Sheep raising was another pastoral activity that had a strong impact on the ecology of the region. Merino sheep, renowned for their incredibly soft wool, were introduced from Europe to New England in 1802. The so called “Merino Craze” swept the region, a boom-bust enterprise that had many farmers in Litchfield county convert all or part of their land holdings into sheep pasture. The industry expanded greatly during the years just prior to the War of 1812, when the British introduced an embargo on all wool product exports to the U.S. This had a great impact on the forests of the region, accelerating overall land clearing and the specialty harvests of hemlock trees. With the extremely high tannic acid content of their bark, hemlocks were the ideal species used to tan sheep hides for the markets to the east. During the five years following the end of the war, from 1815-1820, wool prices collapsed. Despite a slight recovery of the industry in Norfolk after this period, a final plummeting of prices in 1845 brought an end to most commercial sheep raising in the region. As with the dairy industry, increased pastoral activity to the west—following the construction of the Erie Canal—brought new competition that crushed the sheepish enterprises of farmers in New England.

With all this in mind, the most dramatic landscape transformation, by far, came from the iron industry—particularly in the land that would one day constitute Great Mountain Forest. The first iron works in the county was established in Salisbury around 1734. Its various forges and blast furnaces were unknown to the British, and so were decisive in supplying the various munitions and war machines that helped the colonists win the Revolutionary War. Owing in part to the generous quantities of raw ore that could be mined in the area, Salisbury became the most significant iron producer in the thirteen colonies in the eighteenth century.

The rich iron deposits in Salisbury follow a narrow band underground some 100 miles more or less northwards to southern Vermont. Canaan straddles this underground source, and became the primary producer of the immediate Great Mountain Forest region. Three blast furnaces were eventually built along the Blackberry River by the middle 1800s. These specialized in the production of pig iron—bars of iron refined from impure sources (the bars that spill through the feed channel look like piglets nursing on their mother, if you use your imagination), which would then be shipped to different forges and there be shaped into all manner of useful objects. The process, and hence the viability of the furnaces themselves, depended on three main ingredients: raw iron ore,



A 19th century collier's hearth in action.

slabs of limestone to act as a flux to draw out the elemental impurities, and charcoal as the fuel source that could heat these materials up to the required temperatures. Where wood to produce charcoal was growing scarce in Salisbury by the 1840s, it was still to be found in abundance in Canaan, where the region as a whole—and Great Mountain Forest in particular—was only sparsely populated, and hence still held many thousands of acres of hitherto un-harvested trees.

The two major iron manufacturers in the Canaan region bought up huge tracts of nearby forest, in anticipation of the time when demand for wood to make charcoal was at a premium. The coalition of Hunts, Lyman & Co. built the Buena Vista blast furnace in 1847, along the Hollenbeck River in Lower City, to the south of Great Mountain Forest. A few years later in 1853, the Barnum and Richardson Company purchased the Beckley furnace, northwest of the Forest on the blackberry river in Canaan. The majority of the charcoal harvested from Great Mountain Forest was used to fuel these two furnaces. Trees were clear cut in every direction, approximately two acres for every charcoal hearth pile. It is estimated that the Buena Vista furnace alone required 356,000 bushels of charcoal per year to operate, which translated to cutting between 300 and 600 acres of forest. Because young trees were preferred for charcoal production, tracts of forest were often re-cut on a rotational basis—as many as 4 times in certain areas.

The decimation of vast forest tracts was further compounded by the frequent wildfires that sprang up in association with the practice of charcoaling itself. Colliers would pile huge stacks of cut wood chunks on site and smolder them there to create the prized fuel. All too often, stray sparks would escape from these piles and ignite nearby forest—already prone to fire outbreak from the dry slash and dense thickets of young trees left from the act of clearcutting in the first place.

The iron industry reached its heyday in the 1870s in Canaan, followed by a precipitous collapse throughout the end of the century. The Bessemer process, patented in 1856, offered the first commercially viable method for producing steel from molten pig iron, using an oxidation process instead of lime to remove impurities. Its widespread adoption in succeeding decades was a major cause for the decline of the blast furnace iron industry towards the end of the 19th century. In 1903, Hunts, Lyman and Co. sold all its land holdings in Canaan to the town for taxes. Barnum and Richardson soon sold most of its charcoaling lands as well, after becoming heavily mortgaged in 1898. The Beckley furnace continued to operate with



**The still active limestone quarry in North Canaan, now operated by Conklin Limestone Co. No longer mined for furnace flux, the limestone materials are sold as landscape supplies and soil amendments.**

decreasing output until it was shut down permanently in 1919. In 1999, the furnace was restored and stabilized, and designated a Connecticut Industrial Monument. Visitors can go on a guided tour of the site, which details the rise and fall of the iron industry in Litchfield County.

The death of iron production marked the closing of a chapter in the history of Great Mountain Forest. In less than two centuries, the land went from nearly continuous mature tree cover to a broadly denuded scrubland. Pasturing on steep slopes, intensive logging, and fires ignited from charcoaling all contributed to severe soil erosion and nutrient leaching throughout much of the forest. Farm abandonment was ongoing since the 1850s, and by the end of the century, only a few active homesteads remained. Locals in in Canaan and Norfolk came to regard the cut over, burned over forest as a haunted place, and avoided traveling through it if at all possible.



Frederic C. Walcott

Starling W. Childs

## HISTORY OF GREAT MOUNTAIN FOREST (1909 - PRESENT)

### The Childs and Walcott Era: 1909-1932

The genesis of Great Mountain Forest (as we know it today) came about with the purchase of the first parcel of land by Starling W. Childs and Frederic C. Walcott in 1909. The two men were old friends, both Yale graduates and members of the Boone and Crockett Club—a hunter-conservationist organization established by Teddy Roosevelt in 1887. They were seeking land where they could establish a game preserve—primarily for hunting and recreation, but also with an eye towards the broader goal of sustaining a natural landscape for future generations to enjoy. Though their sights were initially set on property somewhere in the Adirondacks, Walcott persuaded Childs to look at land in northwest Connecticut. The early successional scrublands of pin oak and gray birch, left behind from a solid century of clear-cutting under iron industry ownership, were just what they were looking for in terms of wildlife habitat. The Barnum and Richardson Company was eager to sell off such parcels at very low prices, now that producing charcoal was no longer a profitable venture. Convinced of the landscape's potential, Childs and Walcott bought several thousand acres from them between 1909 and 1919, concentrated in western Norfolk in the area surrounding Tobey Pond.

Walcott was a businessman from New York who would go on to hold a number of political offices, which he often infused with his conservation ethics. After moving to Norfolk permanently in 1910 following his first land parcel purchase with Childs, Walcott served as president of the Connecticut Board of Fisheries and Game, chairman of the Connecticut Water Commission, and was eventually elected as a member of the U.S. Senate from 1929-1935. Conservationism was still in an early stage in those days—epitomized by figures like President Teddy Roosevelt and Gifford Pinchot (the first chief of the U.S. Forest Service in 1905), who were primarily concerned with the careful protection and management of natural spaces to promote continuous yields of game and timber. In addition to his passion for maintaining privately owned wildernesses, Walcott was an early proponent of “game in the commons”, the belief that public lands should be preserved in every locality for people to utilize as hunting grounds, and thereby serve to ensure a common, steady food source for the community. Even as he tinkered with game management on his new Norfolk property, Walcott spent much of his energy as senator, and member of various other public offices, in encouraging these socially oriented goals.

Childs' primary role in the project was as chief financier of the various land parcel purchases. He had married the daughter of Charles Albert Coffin, founder of the General Electric Company, and together with his wife they provided more than ample capital for funding the enterprise. Childs also belonged to a long lineage of Swedenborgians, a sect of Christianity whose adherents believe in the spiritual unity of God and the natural world. As a well-known example, Jonathan Chapman, later known as Johnny Appleseed, was an early missionary for the movement, and spread its teachings as he traveled and created apple plantations across the Midwest. Childs' religious upbringing may likewise have provided inspiration for his own conservation ethic, as well as his collaboration with Walcott. Something of the family tradition would continue on in his son Edward, who would in time become the primary molder of GMF as a forestry-centered organization.

The early years on the property were a whirlwind of activity. Walcott and Childs were eager to experiment, and demonstrate how a landscape could recover and provide ample animal habitat, given time and proper management. The pair hired professional gamekeepers to assist in introducing animals into the various habitats of the property. Deer and pheasants were released strategically into young forests, and various species

of waterfowl were specially imported from Canada to establish populations in Tobey Pond. One can visit the pond today and still find remnants of the original feeding pens used for the various wood ducks, pintails, redheads, pheasants, and canvas backs imported to their new home. In an effort to speed up the process of forest regeneration and provide cover for woodland creatures, Walcott and Childs also planted various shrubs and conifers throughout the grounds. One of these plantings, a Norway spruce plantation established in 1919, is still standing to this day (see Forest Management 1: Plantations).

For Walcott in particular, the goal of these efforts was not just to see what could be done on the property, but to use its success as an educational resource for communities and lawmakers at large. In correspondences from those early years, he describes the bucolic scene over at Tobey Pond. In his words, it had become something like a “zoological park” with ducks flocking from all over to mingle with the imported ones, and plentiful pheasants inhabiting the young woodlands, breeding prolifically to swell the population year by year. Excited by their progress, in 1915 Childs and Walcott invited the State Parks Commission to tour the property, as part of their effort to convince the newly formed government organization to purchase a 15,000 acre tract of land for public use. Throughout his life, Walcott continued to give lectures and write articles on the merits of game reserves, including a chapter on the topic in William H. Hornaday’s “Wildlife Conservation”—a collection of presentations by a former professor of the Yale Forest School.

### **The Ted Childs Era: 1932-1996**

Though planting and game management activity was ongoing throughout the 1920s, no new land parcels would be acquired until the following decade. By this time, S.W. Childs’ son, Edward (known as Ted), was grown to adulthood, and began to take an active role in managing the property. Ted graduated from the Yale Forest School in 1932, whereupon he took on a string of illustrious land management jobs. After getting a second master’s degree in mining and mineralogy from Columbia University in 1933, Ted worked for the Beryllium Mining Corporation, and took a six-month field operations appointment in the Mississippi Civilian Conservation Corps to oversee the creation of a battlefield national park outside of Vicksburg. Starting in 1942, Ted worked for the U.S. Army in Costa Rica, where he was charged with establishing cinchona tree

plantations, a species used at the time to produce anti-malarial medication for military activities abroad. It was only after his discharge in 1946 that he returned permanently to Norfolk. Even from a distance, however, Ted proved to be very active in the management of the property during this period. With his new background in forestry, Ted was interested in shifting the focus of property management towards fostering a holistic, productive ecosystem—a great expansion of the earlier mission which had been centered upon the stewardship of individual animal species.

Shortly after graduation, Ted took over his father’s half share in the property. Together with Walcott, the two spent the next twenty years aggressively buying up new parcels, expanding the forest, more or less, to its current expanse of approximately 6,500 acres. Many of these tracts were more cut-over iron industry lands held by Hunts, Lyman & Co. and Barnum & Richardson, though a number, including the Root, Mansfield, Dorman, and Chattleton properties, were abandoned homesteads, with different lasting human legacies and forest compositions. To oversee their varied management objectives, Ted hired a sequence of foresters, beginning with a man named Eckels in 1934. Bill Preuss, followed him the year after, and worked from 1935-1940, creating many of the ponds that exist on the property to this day, including Wapato Pond (in 1936) and Wampee Pond (in 1937). These were former wetlands, strategically dammed to create year-round bodies of water to provide new habitat for fish and waterfowl.

Aside from a one-off salvage operation of dying chestnut trees in 1918, no timber harvests or inventories were conducted on the properties until the 1940s. As providence would have it, the dawn of their forestry efforts coincided with a re-unification, of sorts, between Ted and his alma mater, the Yale School of Forestry. In 1938, a hurricane leveled the Yale-Myers Forest in eastern Connecticut, which had only just begun to be used during summers for their annual field training intensive. Forests in the northwestern corner of the state were relatively unaffected by the storm, so Ted offered to donate seven acres of his and Walcott’s land to the school so they could continue their yearly program, and even established a fund for the construction and continued maintenance of a permanent camp there<sup>2</sup>. The camp buildings were completed in 1940, and, in the summer of 1941, hosted the first cohort of Yale Forestry School students, where they learned about forest inventory, land surveying, harvesting, and conservation.

Just a few years later, in the summer of 1943, GMF conducted

---

2 The fund was dedicated in the name of Ted’s chauffeur, Joseph Taylor

their first ever timber cruise—a quick, property-wide survey to estimate standing timber volume. Art Hart, Ted’s hired forester of the time, led the assessment, and was assisted by students from the Forestry School. Alone and in pairs, the team collectively reconnoitered the entire forest, sampling tree diameter and height along randomized, pre-selected transects.<sup>3</sup>

After assembling and analyzing the collected data, Art estimated the total board feet of merchantable timber in the forest (a board foot is a unit of lumber measurement, often applied to standing trees in timber potential assessments. It is equal to the volume of a one-foot board that is one foot wide, and one inch thick). It proved to be a considerable amount,

---

<sup>3</sup> One of these transects led two of the students unexpectedly to the site of a downed army aircraft. It had crashed onto the western slope of Blackberry Hill just a month earlier, and no one knew what had happened to it until their discovery. Once informed of its whereabouts, a military crew removed the wreckage in a single day. The family of the pilot who had died in the crash erected a memorial stone on the site in his honor. Though no path leads there, the obelisk with its inscription still stands for wandering travelers to find.



Ted Childs, circa 1950s.

when one considers that most of this land was recently either aggressively logged, charcoaled, farmed, or pastured just a handful of decades earlier. It was also the beginning of a great collaboration between GMF and the Yale School of Forestry. Every summer for the next 25 years or so, students assisted with various inventory analyses and other projects as a component of their required field training.

Ted’s donation of the 7 acre Yale Camp is but one example of his generous spirit, and his desire to utilize his land as a means to reach out and collaborate with other groups. In 1946, after years of travel and working in different places, Ted moved permanently back to his family’s Coolwater Estate along the eastern edge of the forest, ushering in an era of yet heightened activity and involvement. In 1950, the year after Walcott’s death, Ted bought out the half share from his heirs to become the sole owner and proprietor of the forest. It was at this time that the property officially became known as Great Mountain Forest, so named for the large peak it contains near the southwestern boundary, along Under Mountain Road (once known to early settlers as Canaan Mountain, hence the name of the intersecting Canaan Mountain Road where the GMF administrative office currently sits). After a succession of short stunted forest managers, Ted hired George Keifer, who worked from 1947 to 1952. George’s first task was to create Tamarack Pond, around which the interpretive Tamarack Trail would eventually be constructed. From 1948 onwards, he and his subsequent forester successors would be in charge of Ted’s newly created forest internship program. Every summer, (up through the present day) several forestry students from around the country are hired to come live at GMF and work as members of the crew. Besides being a great help in accomplishing the diverse tasks of managing the forest, it offers a great opportunity for these interns to learn practical forestry skills, and fosters deeper engagement between GMF and the various communities to which it belongs.

In 1950, during the middle of George Keifer’s tenure as land manager, Ted hired a second forester, Darrell Russ, to assist with timber inventory, the establishment of red pine plantations (see Forest Management 7: Red Pine Salvage) and other duties. In a career that lasted 42 years, Darrell was the longest running employee in GMF history. Sam Hawley was hired as a forest technician shortly thereafter in 1953, and would work alongside Darrell for almost the entire extent of his tenure. Given this consistent management leadership, and the fact that Ted was by now permanently settled in Norfolk, the stage was set for the undertaking

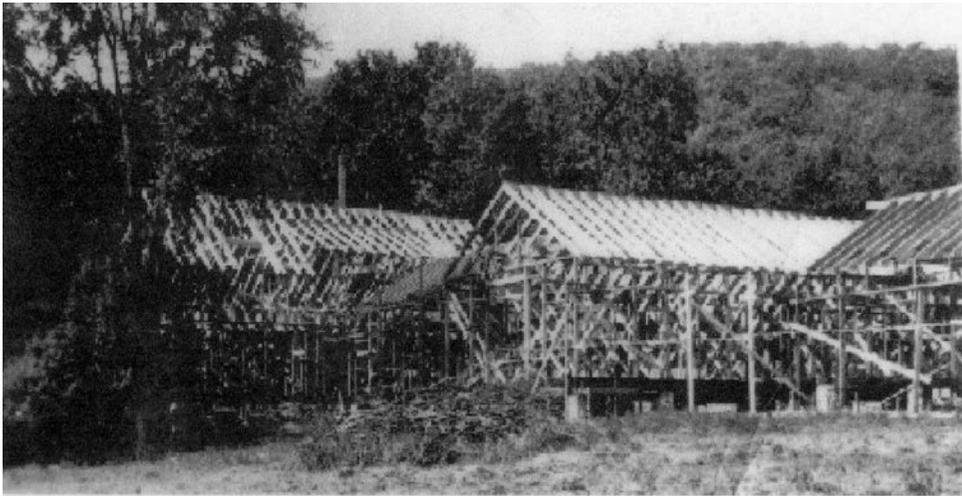

Initial Yale Camp construction, circa 1940.

of some of GMF's most ambitious, far-reaching initiatives, such as the expansion of Ted's maple syrup production operation, "Coolwater Maple Syrup" (Forest Management 8) the establishment of many unique exotic conifer plantations and Christmas tree orchards (Forest Management 1), the support of dozens of research projects in the forest (see Research Sites), and the establishment of the GMF Corp.

Outside of his life at Great Mountain Forest, Ted also set down deep roots within the greater Norfolk and Connecticut community. From 1947 to 1971, he served as Park and Forest Commissioner for the state of Connecticut, and as chairman of the Connecticut Tree Farm Committee, an organization charged with certifying privately owned lands that practice sustainable forestry methods. In an initiative closer to home, in 1956 Ted used his own money to fund the creation of the Norfolk Curling Club, which is still active, and even hosts regional championships. He and his wife Elisabeth raised four children in Norfolk: Elisabeth, Starling, Anne, and Edward Jr. Continuing a family tradition, Star, Ned, and Anne's future husband, Chip Collins, all attended the Yale School of Forestry & Environmental Studies, thereby strengthening its ties with GMF. In 1962, Ted created the Great Mountain Forest Corporation as a way to fund research and other projects in the forest. The private foundation became the technical owner of certain parts of the forest, including the weather station, Tobey Beach and the surrounding "North Forty" property, and timber sections 13 and 14 at the southernmost portion of GMF (since Ted owned the corporation, these lands still de facto belonged to him). In

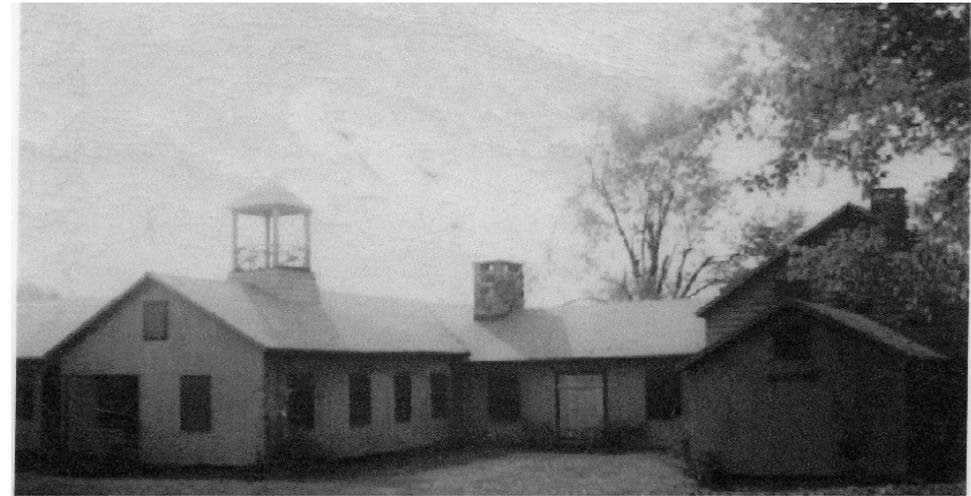

The completed camp buildings, shortly thereafter.



The Yale Camp today, following recent renovations.

creating this organization, Ted was able to fund research that occurred there without any tax consequences. The GMF Corp operated with its own governing board which met on a yearly basis, consisting of Ted, his son Star, and former Yale School of Forestry dean Francois Mergen, a plant geneticist who oversaw several plantation experiments in Great Mountain Forest (see Research Sites 4: Mergen's Pinetum). In the 1980s, Childs had deed restrictions put on sections 13 and 14. As a result, this section of

the property would not be part of the later easement agreement that was finalized in 2003.

That same year, 1962, Ted installed a sawmill on the grounds near the current forestry office (which was then a barn, that burned in 1990). Unlike the maple syrup, timber harvests, and Christmas tree plantations, all of which existed to produce consumer products, this mill was used only to process wood for buildings and bridges within Great Mountain Forest. It stands accompanied by a nearby wood working shed, where the lumber is dried and finished, and from there used for various construction projects. Many of the later buildings, such as the current day sap house and forestry office, were built with wood entirely harvested and processed at GMF.

Even as activity ramped up elsewhere in the forest, the forestry students at the Yale Camp spent their last summer field training there in 1967. At that time, enrollment was down in the school, and priorities were shifting to encourage students to do internships elsewhere during their summers. The Yale president of the time, Kingman Brewster, wanted to sell the camp back to Ted, and even offered to foot the bill for its demolition. Ted, however, insisted they hold on to it for the time being. From 1972 to 1982, the camp was leased to the University of Hartford for their yearly 2-week summer ecology course. Ted's son, Star, attended Yale FES from 1978-1980, and was instrumental in getting students to return to GMF as a component of the new student orientation program (called modules, or MODS). The first MODS was in 1977, and at the time consisted of field exercises in the New Haven area. Star pushed hard trying to persuade the school to return to GMF, which they finally did starting in 1983—initially as a one day excursion that eventually became the four day long MOD that exists today. Though Star would go on to create his own forestry consulting company (EECOS) in Norfolk, his connection to GMF remains deep and profound. He has been a fixture of the MODs curriculum for many decades now, uniting generations of students with his wisdom and humorous spirit. When not in use by Yale, the camp is leased back to GMF, who have used it over the years to host a great many different school groups and adult workshops.

Through the 1970s, Great Mountain Forest continued to grow larger through successive parcel acquisitions, which afforded opportunities for more complex and expansive timber prescriptions. Though inventory had been ongoing for some decades by this point, harvests in the 1950s and 60s were mostly focused on white pine thinning on abandoned pasture lands. By the 1970s, however, they began to do more ambitious

oak shelterwood cuts on the Number 4 Trail region in the heart of the forest. Darrell Russ was responsible for the delineation of Great Mountain Forest into different harvest zones—a system still used by the current GMF foresters. By 1976, he also oversaw the planting of over 200 acres of various exotic conifer species for use in his ongoing quest to discover the perfect Christmas tree, which at the time was still a thriving business at GMF (See Forest Management 1: Plantations).

That same year, a young man named Jody Bronson joined the summer crew, fresh from the forest technician program at Unity College. He continued to work seasonally at GMF throughout his undergraduate studies at Keene State College. In 1978 he joined the staff as a full time member, and, except for a one year stint elsewhere as a contract logger in 1981, has been working at GMF ever since. It was also around this time, in the mid to late 1970s, that Ted began to step back from the day to day operations in the forest. He became fascinated with rock gardening, and created magnificent arrangements in the garden next to his Coolwater Estate, complete with strange stones and various small alpine plants. It was so impressive that members of the New York Botanical Garden came up to

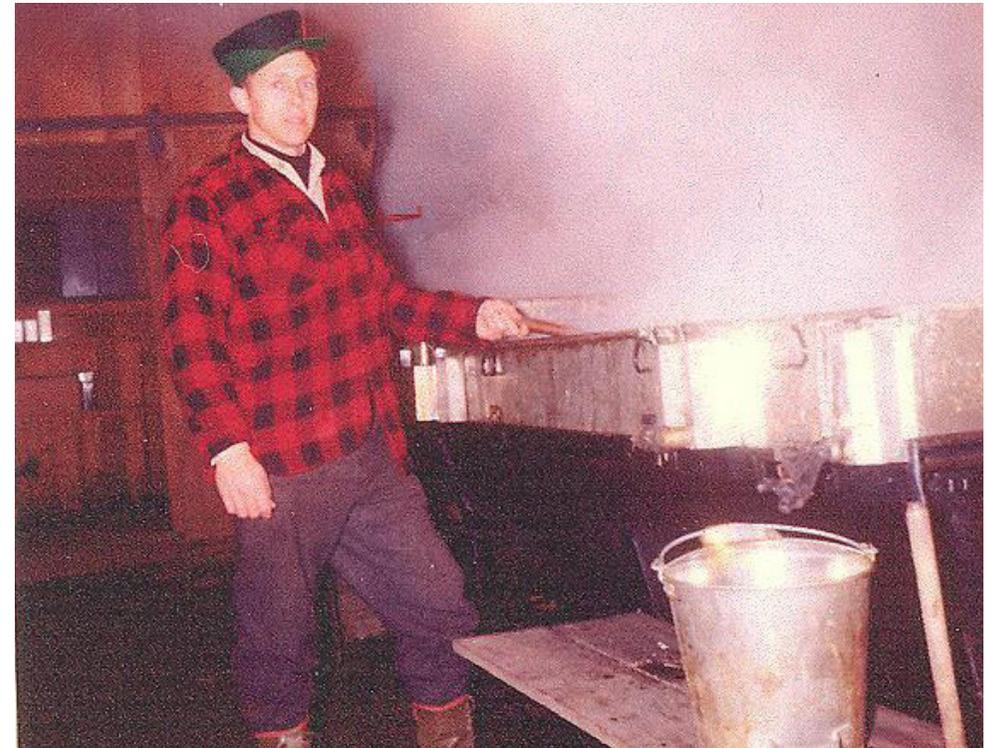

Darrell Russ, operating the evaporator in the old GMF saphouse.

see it on weekend tours. By this time of course, Russ had a good handle on what needed to be done, though the two still continued to meet for coffee every morning to discuss matters concerning the forest.

Darrell Russ worked steadily and faithfully at GMF until his retirement in 1992, when Jody Bronson became the forest manager. Bronson kept up the various forestry operations, bringing his own mixture of practical and aesthetic sense of forestry to the organization. Darrell's son, Russell, who also began his GMF career as a summer intern in 1988, eventually joined the official staff in 2001.

### **EASMENT NEGOTIATIONS AND THE NGO ERA: 1996 - PRESENT**

With Ted's passing in 1996, the Childs family had to make some difficult decisions about the future of Great Mountain Forest. The property went completely to his wife Elisabeth, who assumed ownership unencumbered. However, they knew that when she herself passed away, there would be a huge tax burden on the children in order to retain the land. The family's wealth, though substantial, was already heavily invested in Great Mountain Forest. Had the lands remained in private ownership, the family would have been forced to sell off much of the property. A land buying craze was in progress in Norfolk at the time, and the parcels would have fetched high prices from eager developers.

Star Childs and Chip Collins began discussions with the family about putting the land under an easement agreement. The 1990 federal farm bill had established the Forest Legacy Program to protect forested land holdings by buying up the development rights and holding them in perpetuity, even if the land itself changes hands. The Childs family decided this would be their best route to take, though it would not be an easy process. Getting federal money to buy the development rights requires a series of applications and negotiations with officials at the state and federal level, who had to be convinced of the merits of the property in question.

The process also precipitated important internal conversations within the family about how an easement agreement would change the relationship between the forest and the public at large. Though in its history GMF had played host to multitudes of interns, school groups, workshops, clubs, and researchers, these had always been authorized under the discretion (and benevolence) of Ted and his kin, as the sole owners and proprietors. To convince the state to buy the conservation easement rights, however, they were asked to consider some form of public access in the



**Starling and Ted Childs, standing by the frame of the new Forestry Office, circa 1990.**

agreement, as their argument hinged on the great value of the space to the community at various levels. Understandably, determining the scope and magnitude of that access was a difficult process. For almost a hundred years prior, the forest had been private, and all involved felt the same strong sense of attachment towards the land, as well a burden of responsibility to ensure that its unique and often fragile ecosystems would not be overrun by an influx of unmonitored visitors.

Given these and several other inherent difficulties, the process dragged on for years, driven always by the looming threat that Elisabeth would pass away before the easement could be secured. The chief

negotiators were Star Childs, Chip Collins, and Deputy Commissioner of the Department of Environmental Protection, David Leff. Leff served as the chief negotiator for the easement on the part of the state. Childs, a long serving director of the Connecticut Forest and Park Association, was friendly with a number of state level politicians and environmental leaders, and his education in the environmental sciences and work at EECOS gave him the knowledge and language to describe the GMF landscape in a compelling way. Collins was the director of the Forest Land Group, a timberlands management and investment organization, and so similarly had a strong background in negotiating property sales. Though Leff and many others in the department were in strong favor of a deal being struck, it took a long time to figure out the difficult details.

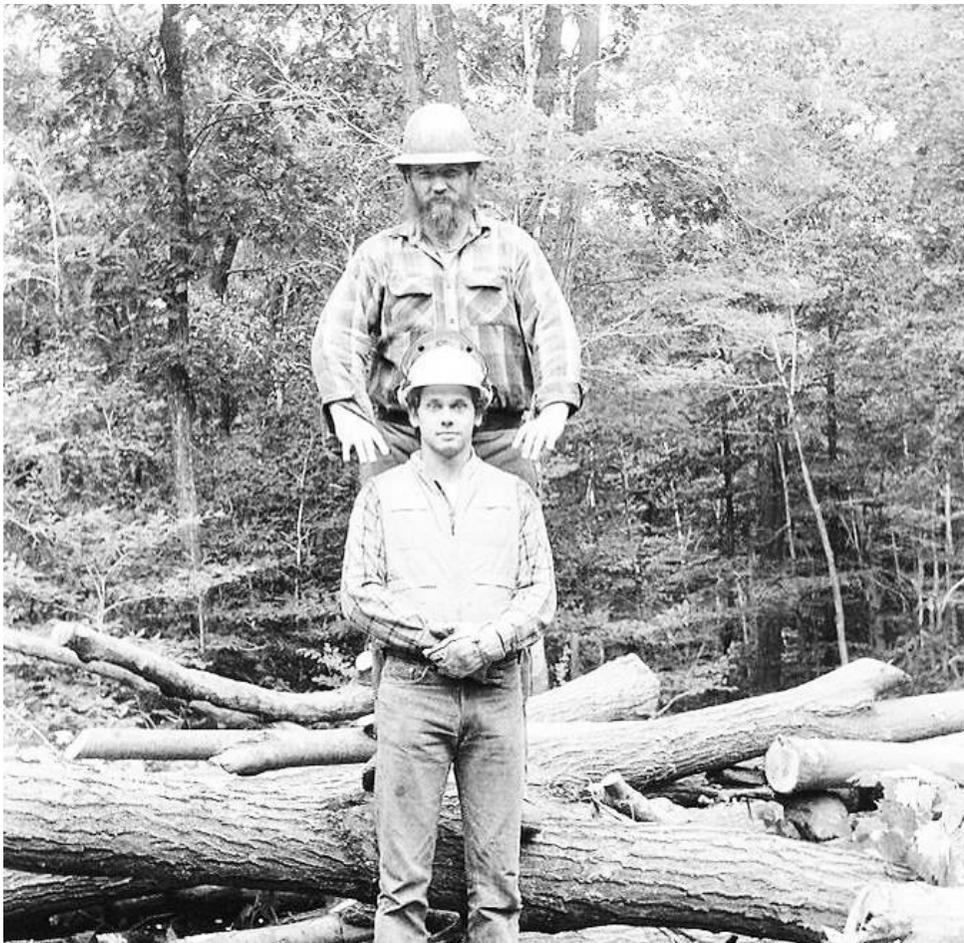

Jody Bronson and Russell Russ, circa. 1988.

In the end, the emergence of GMF as an NGO was a two-step process. In 2003, the state of Connecticut finally agreed to match federal forest legacy funding with their own funds and purchased the development rights to the bulk of GMF—some 5,500 acres—though ultimately 75% of the funds for the purchase came from the federal farm bill. Simultaneously with the filing of the legacy easement in the towns of Canaan and Norfolk, Elisabeth Childs donated her title in fee to those same lands to Ted's earlier established Great Mountain Forest Corporation. In the year that followed, the formerly private GMF Corp. was converted to a private operating foundation. This is a more specialized 501-c3 tax exempt designation, and essentially functioned as step towards making GMF more of a public entity. Elisabeth put almost all of her land, including the 5,500 acres of the easement, under the GMF Corp., thereby transferring that vast bulk into NGO status. Upon her passing in 2009, Elisabeth Childs deeded several additional unrestricted forested parcels in her will. Among these was the Mountain House, which currently serves as GMF's administrative headquarters. The proceeds of the sale of the easement were placed in a charitable remainder trust, with the main purpose of creating an endowment for the organization. A small portion of the trust's income was used to support Elisabeth in the final years of her life between 2003 and 2009.

In many ways, things at GMF after the easement agreement have gone on much as before. Timber harvesting and habitat improvements are still permitted on most of the property, so long as no new permanent structures are built. The forestry staff still keeps up these operations, as well as a number of other projects. However, the non-profit designation has enabled them to expand greatly in terms of outreach opportunities. It enabled the funding of additional staff positions to develop programs and foster broader connections with other organizations. With the official transition of property and endowment funds in 2009, they were able to hire Paul Barten as a director of operations, to begin building up the social base of the new (yet in some ways, very old) GMF entity. Jean Bronson, a former cook at the Yale Camp and tax collector in nearby Falls Village, had previously done children and adult programs at GMF on an ad-hoc basis. In 2012 she came aboard the staff full time to do this work, as well as manage book-keeping of the various salaries, expenses, and donations. In 2014, Paul stepped down, and Hans Carlson came aboard as the new director. All four of Ted and Elisabeth's children serve on the board of directors, ensuring that the history of the family remains an important part

the mission and lasting legacy of Great Mountain Forest, even as it grows in exciting, new directions.

## CURRENT OPERATIONS AND PROGRAMS

Though it has grown into a private non-profit organization in recent years, the underlying mission of Great Mountain Forest is the same now as it has been for the past century: to serve as a model for how a working forest can benefit both natural and human ecosystems. The endowment provides some of the resources to allow for additional staff and programs, expanding the reach and influence of the organization. This is augmented by annual giving by the supporters of Great Mountain Forest, as well as grants from foundations and the government.

GMF is fully accessible to the public during daylight hours for hiking as well as cross country skiing and mountain biking on select trails. The space is also available to larger groups for private events, though the staff appreciates being notified ahead of time before such events.

GMF offers a variety of programs and workshops throughout the year which cater to people of all different age groups. The Great Mountain Forest Lecture Series features book authors and lecturers who come to speak about their areas of expertise. GMF director Hans Carlson often gives presentations on the history of landscape use and forest stewardship practices in the region, drawing from his years of training as a historian and experience in the woods of the northeast.

Other events are more hands on, and make wide use of GMF's stewardship practices and natural landscape to provide learning experiences for the broader public. Many programs are hosted in conjunction with experienced professionals, such as the workshop on birds in the working forest, or the field walk with the Connecticut Department of Energy and Environmental Protection (DEEP) on the future of the New England cottontail rabbit (see Forest Management Sites 10). Others, like the winter wreath making workshop, maple syrup demonstrations, native dye workshop, and myriad interpretive hikes, are led by members of the GMF staff themselves.

The Yale Camp, well-known within the School of Forestry and Environmental Studies for the MODS orientation every August, allows GMF to host various groups for more extended periods of time. The Christodora Summer Ecology program brings low income high school students from New York City to spend two weeks at the camp, where they learn about the forested landscape and design and conduct their own field

studies. GMF, in association with the Connecticut Cooperative Extension Forester, hosts the Connecticut Coverts Project, whose mission is to educate private landowners about managing their properties sustainably. Thanks to the facilities made available by the existence and generous leasing of the Yale Camp, GMF is able to host long-term programs that allow for deeper engagement with the property.

Children from nearby Norfolk, Canaan, and Falls Village are frequent visitors to the Childs Center, coming in school field trips and summer day camps throughout the year for hands on experiences in nature. These varied programs, organized by GMF's Jean Bronson, include interactive art projects using natural materials found in the forest, interpretive hikes along some of the many trails, and maple syrup production demonstrations. GMF also hosts the Project Learning Tree "Children's Literature and Nature Project", which provides workshops for school teachers on methods for integrating nature-based education activities into their curriculums, including discussions on reading materials and walks in the woods with GMF staff members.

The GMF Field Day is a family-oriented annual event, bringing together the local Litchfield County community as well as affiliates from all over the region. Attendees are treated to a picnic lunch, tour of the historic Stone Man Trail, and various demonstration booths. The culminating event of the day is the canoe raffle. Every winter, Jody and a group of dedicated volunteers obtain and fully restore a collectible canoe, which they raffle off at this event to raise funds for further GMF programming.

As alluded to already, many of these structured events are in some way related to the working forest aspect of GMF operations. Jody Bronson, Russell Russ, and forest technician Wes Gomez all work hard throughout the season to manage the forest sustainably for timber, habitat, and human access. GMF hires three interns every summer to assist in these efforts, which provides aspiring land resource managers with valuable experience in the forestry arts.



Star Children, demonstrating the sugar maple tree growth form to a group of visiting school children. Maple syrup operations are a source of great entertainment for people of all ages.



GMF director Hans Carlson, leading a presentation for the Christadora Summer Ecology Program students.

## RESOURCES

*Cronon, William (2003) Changes in the Land: Indians, Colonists, and the Ecology of New England, revised ed. Hill and Wang, New York.*

*Delcourt, Paul A., and Hazel R. Delcourt. (2008). Prehistoric Native Americans and Ecological Change: Human Ecosystems in Eastern North America since the Pleistocene. Cambridge University Press, Cambridge.*

*Drake, James (2000) King Philip's War: Civil War in New England, 1675-1676. University of Massachusetts Press, Boston.*

*Lavin, Lucianne (2013) Connecticut's Indigenous Peoples: What Archaeology, History, and Oral Traditions Teach Us About Their Communities and Cultures. Yale University Press, New Haven.*

*Winer, H.I. (1955) The History of the Great Mountain Forest, Ph.D. Thesis, Yale University, New Haven*



The GMF Smokey Bear Story Hour at McMullen Pond.



The 2015 summer forestry interns, hard at work repairing the bridge on the Number 4 Trail.



Smokey pictured among adoring fans.



Raffle for restored canoe in progress at the 2015 GMF Field Day.



## SPECIES OF INTEREST

IN GREAT MOUNTAIN FOREST

Great Mountain Forest is lush with a variety of flora and fauna. What follows are brief descriptions of selected interesting and ecologically significant species, and their relevance to Great Mountain Forest. This is by no means an exhaustive list—consider it an introduction to the cast of major or otherwise notable characters who star throughout this field book. For more comprehensive inventories of GMF biota, please see Appendix II.

### **Eastern Hemlock (*Tsuga canadensis*)**

A conifer in the pine family (*Pinaceae*) whose branches bear rows of two-ranked, flattened needles, and tiny cones. It is often a large tree, 60-70 feet tall, though it can grow much taller (up to 160 feet) given time and appropriate conditions. The canopy is often very deep, with many active branches growing beneath one another far down the trunk. The bark is brownish in scaly blocks on younger trees, and grows gray and furrowed as they mature. Extremely old (250+ years) hemlocks can be identified by the presence of crustose (crusty, hard to peel off) lichens, which accumulate on aged trees after tannin production in the bark begins to decrease. The hemlock varnish shelf (*Ganoderma tsugae*) is a conspicuous species of bracket fungi that grows almost exclusively on hemlocks, and is a common sight in Great Mountain Forest.

Eastern hemlocks grow prolifically on moist rocky ridges, at the wet bottoms of ravine slopes, and along cool forest streams. It is an extremely shade tolerant species, growing slowly in the understory beneath faster growing pines and hardwoods for many years before ascending to canopy dominance. Once there, the intense shade created by their deep evergreen crowns tends to inhibit the regeneration of other species. Hemlock forests



A tall hemlock-dominated canopy.

thus often have very open understories devoid of even an herbaceous layer, either growing in near monoculture stands or alongside American beech and other hardwoods.

Hemlock has limited demand as a timber product, though makes serviceable boards when grown in the right conditions. Open grown and



Hemlock varnish shelf growing on a recently fallen trunk in GMF.



Close-up of hemlock needles showing evidence of hemlock wooly adelgid infestation.

older growth hemlocks are prone to “shake”—trees with ingrown branches that cause the trunk to shatter when felled. Eastern hemlock is the only unusable tree species in charcoal production. As a consequence, certain stands were left untouched by the industry in the Great Mountain Forest region, while others were cut down and left to rot in order to promote

the growth of more favorable species. The extremely high tannin content in the bark made hemlock trees useful for tanning hides, and there was a peak in their use for this purpose throughout the 19th century. Winer (1955) surmises that hemlocks are extremely susceptible to fire, and cannot regenerate in recently burned areas. He believes this accounts for their conspicuous absence in certain areas of the Great Mountain Forest, where runaway brush fires started from charcoal hearth sparks were a common occurrence.

The hemlock wooly adelgid (*Adelges tsugae*) is an invasive insect species that is decimating hemlock species across their native range. It was introduced to eastern North America from Japan in the early 1950s, where it has slowly spread to infect hemlocks growing in 11 states. The adelgid belongs to the insect order Hemiptera, which includes the aphids, white

flies, and scale insects. They reproduce asexually, laying hundreds of fuzzy eggs on the undersides of hemlock leaves—the telltale sign that a tree has become infested. The adults feed on the phloem sap of new shoots, preventing fresh growth and inviting desiccation and infestation by other pathogens. In this way, untreated trees are often killed within 5-10 years. The hemlock wooly adelgid is common in the Great Mountain Forest, though many areas are not yet affected. The harsh winters of the past several years may have helped reduce adelgid populations in the region, but the long term effects are still expected to be catastrophic. As it is the single most abundant tree species of the Great Mountain Forest, its eventual extirpation will certainly result in a dramatic restructuring of the canopy composition in the coming years.

Eastern hemlock currently accounts for 40% of the canopy cover at the Great Mountain Forest (GMF Stewardship Plan 2010). It is most abundant in lowlands and mesic areas, especially along streams. There are several impressive old growth stands throughout the Norfolk side of the forest, some of which may be 400 years old (see Natural Communities 7: Old Growth). Research on the lifecycle and field adaptation of the hemlock wooly adelgid at GMF is currently being conducted by Dr. Carol Cheah of the Connecticut Agricultural Station.

### **American Chestnut (*Castanea dentata*)**

Once a massive tree, frequently 100 feet tall with deep, furrowed bark. Its leaves are long, with many pronounced teeth, growing alternately in two ranks down each twig. Superficially they resemble the leaves of the American beech (*Fagus grandifolia*), with whom it is related. However, the beech leaves tend to be shorter and more egg shaped, with blunter, less pronounced teeth. Today the American chestnut is most commonly found as an understory multi-trunked shrub, often co-occurring with oaks.

The American chestnut was once the most common tree in many areas of its natural range—accounting for as much as 25% of total canopy cover in the southern Appalachian Mountains. The strong, rot resistant, yet relatively light wood was used for almost everything: construction timber, fence posts, telephone poles, caskets, crates, and all manner of furniture. The high tannin content makes the wood resistant to warping, and the bark was often used as a means of tanning hides into leather. The sweet, plentiful, protein-rich nuts, so abundant every fall, were a major food resource for Indian groups, pioneer mountain families, and animals alike.

In 1904, a pathogen known as the chestnut blight (*Cryphonectria*



LEFT: Chestnut stump (right) sprout on Chatleton Road.

RIGHT: Standing with a very large American chestnut, discovered within a group reserve in one of the recent harvests along the Number 4 Trail.

*parasitica*), was accidentally introduced to the Bronx Botanical Garden from a shipment of Japanese chestnut trees. The airborne fungus enters existing wounds in the tree's bark and works its way through the vascular tissue, which ultimately cuts off the flow of nutrients and kills the tree. The blight quickly spread across the entire native range of the American chestnut, killing an estimated 4 billion trees within a matter of decades. State and local efforts to treat infected trees and create quarantine zones were universally unsuccessful. Salvage logging to harvest healthy trees before they succumbed to the disease was already widespread by the 1910's, and likely destroyed many individuals that may have had an innate resistance to the blight. Salvage logging of large living trees occurred in the Great Mountain Forest in 1917 and 1918, and standing dead trees (snags) were cut in 1939 and 1940 to make fenceposts (Winer 1955).

Because the blight does not destroy the root system, chestnut trees are able to re-sprout from the base. These grow as multi-trunked shrubs for 5-10 years before they become infected, senesce, and re-sprout once more. Chestnut stump sprouts are common in the Great Mountain Forest, particularly along both sides of Chattleton Rd. heading south from Yale Camp. There is a very large individual (around 15 inches in diameter) near the Number 4 Trail, in the harvest area across the road from Wapato Lookout.

The American Chestnut Foundation was established in 1983 with the goal of using selective breeding to restore the species. By hybridizing American chestnuts with Chinese chestnuts—which are resistant to the blight—and backcrossing those offspring with surviving American chestnut individuals for five generations, the resulting progeny will contain individuals that have 94% American chestnut DNA yet still possess resistance. Nuts of the first individuals of this fifth generation of backcrosses were collected in 2007, and are now being planted in experimental plots throughout their native range. One of these sites is a small plantation in the Great Mountain Forest, which was planted in 2010 (see Research Sites 3).

### **Mountain Laurel (*Kalmia latifolia*)**

A common shrub in New England, with multiple, twisted trunks and shiny, pointed, leathery leaves. It often grows in very dense patches, shading out any undergrowth with its thick evergreen foliage. In Connecticut, mountain laurel flowers in early to mid-June, with a lavish display of white to pinkish bowl shaped flowers arranged in heavy, branching clusters.

As an evergreen plant, mountain laurel is effective at inhibiting the regeneration of plants beneath it. Like many of its fellow species in the Heath family (*Ericaceae*), mountain laurel thrives in nutrient poor environments. Logging crews, after completing a timber harvest, are often instructed to crush any nearby patches of mountain laurel with their machinery so as to give regenerating tree species a chance to sprout and grow above the shrub layer. It is often found in moister areas, even creeping into the understories of wooded swamps and the edges of bogs.

Given Great Mountain Forest's extensive history of exploitation in the 18th and 19th centuries, it is not surprising that mountain laurel grows in abundance here, often concentrated around old homesteads and charcoaling sites. Though mostly a nuisance to foresters, the species does have notable qualities. The flowering during the early summer is a beautiful sight to behold. The Cherokee prize the wood for decorative woodcarving, and historically crushed its leaves to use as a salve for wounds and skin irritations. Its best known use today is as the source of material for laurel wreaths during the Christmas season.



Mountain laurel in full flower in June.



Close-up of red spruce cones and needles.



Red spruce bark detail.

### Red Spruce (*Picea rubens*)

A medium sized tree (60-70 feet) more commonly known in northern New England and Nova Scotia. Like all spruces, the growth form is straight and pyramidal, branches tapering evenly all the way up the trunk. The short needles, unlike those of the hemlock, are short and prickly, and grow all the way around the orange-reddish twigs.

Though typically a mountaintop species throughout most of its natural range, in Great Mountain Forest red spruce is found almost exclusively in forested wetlands, co-occurring with red maple and black gum in the canopy. It is distinctive here for being near the southernmost extent of its range within New England. Though never the component of a commercial harvest here at GMF, it is frequently cut farther north for boards and pulp. The quality resonance of its heartwood also makes red spruce a preferred species for the making of musical instruments, chiefly violins.

### Japanese Barberry (*Berberis thunbergii*)

A small shrub (1-3 feet) with thorny, yellowish branches and small pointed leaves. In the fall it produces small, oblong, red berries that persist late into the fall as the leaves turn a distinctive bright yellow.

Japanese barberry is a common shrub planted on lawns, landscaping, and in ornamental gardens. It was originally introduced to compete with the European barberry, which it has now effectively replaced. It is found most densely in GMF in lowlands and next to running water, especially in areas of former human habitation. Thick pockets of infestation occur in the low elevation pine forest to the south of Canaan Mountain Rd, and in the wetland to the east of the “Raggy Lot” spruce plantation off of Jean’s Trail. According to GMF forester Russell Russ, barberry was planted heavily in the region in the 1960s, to encourage the reintroduction of the wild turkey (though never at GMF).

As a component of their duties over the summer, GMF forestry interns are responsible for conducting surveys along all the major moving water bodies in the forest, noting the location and density of any barberry populations. Current eradication efforts are limited to the prevention of more widespread infestation in new parts of the Forest. This entails manual pulling or herbicide application—both slow, labor intensive processes. In the future, if funding becomes available, a more intensive effort to control the barberry may be undertaken.

In her program on natural dyes, GMF program director Jean



Yellowing foliage in the fall, with persistent red fruits.

Bronson successfully created a rich yellow color by boiling Japanese barberry stems and leaves, which she used to dye mordant treated wool fibers. It is a good example of using creative means to make the most of an invasive species.

### Oaks (*Quercus* spp.)

The oaks comprise one of the most diverse genera of tree species in North America. They tend to be large and heavy-wooded as a group, though some, like the local bear oak (*Quercus ilicifolia*) exist as shrubs or



Dense Japanese barberry growing into High Pocket Swamp.

treelets. All oaks are wind pollinated by tiny flowers that unfold in the spring along with new leaves, and mature into acorns in the fall.

Oaks in eastern North America are typically sub-divided into two groups. Species in the red oak group (*Erythrobalanus*) have leaves with bristle-tipped lobes, more pointed buds, and tend to have darker and more ridged bark. Species in the white oak group (*Lepidobalanus*) have leaves that lack bristle tipped lobes (usually rounded), smaller and more blunted buds, and tend to have lighter, more blocky and peeling bark. At GME, four oak species occur frequently, two from each of these groups:

## Red Oak Group

**Northern Red Oak (*Quercus rubra*):** Bark is dark with smooth ridges that form distinctive “silver rivers” in the upper portions of mature trees. Leaves are a smooth green underneath, and on average have shallower lobes and a duller complexion than those of the eastern black oak. Acorns are big with broad, shallow cups that feature tightly laced scales.

**Eastern Black Oak (*Quercus velutina*):** Bark is gray and blocky (unusual for the group), with less pronounced “silver rivers” above. Leaves have tufts of orange fuzz clustered around the main veins, and on average have deeper lobes and shinier complexion relative to the northern red oak. Acorns are smaller, with deeper caps that feature shaggy scales.

## White Oak Group

**Eastern White Oak (*Quercus alba*):** Bark pale gray, peeling in strips or blocks. Leaves with many deep, rounded lobes. Acorns are narrow, with a shallower cup than the chestnut oak.

**Chestnut Oak (*Quercus montana*):** Bark extremely blocky with very deep furrows. Leaves lack proper lobes, and instead have rounded teeth that taper to a point at the tip. Acorns are even narrower than the eastern white oak, and have deeper cups.

Oaks are one of the most important (and diverse) tree groups in the eastern deciduous forest. The acorn mast is an important food source for wildlife, and can be eaten by humans if boiled to leach out the tannic acid. Already the dominant tree species in the region for the past 6,000 years, oaks came to occupy the niche of the ecologically similar American chestnut when the latter was wiped out by the chestnut blight over the past century.

Oaks as a group compete well on drier sites, but within the genus tend to be partitioned along a fine moisture and elevation gradient. Of the four common species at GMF, red oak occupies the most mesic sites, occasionally co-occurring with white oak in steeper, rocky woodlands. Black oak and chestnut oak are most abundant on excessively well drained sites, often growing stunted on rocky outcrop ledges and hilltops. Within subgenera, oaks are well known for hybridization, particularly between red oak, black oak, and the less frequently occurring scarlet oak (*Quercus coccinea*). This tendency to cross-breed helps maintain genetic diversity, which is



Young black oak leaves in early spring.



White oak bark, with bear claw markings.



Multi-trunked red oak, sprouted from a long ago logging. By coring and aging one of the boles, one can estimate the date of the harvest.



Emerging white oak leaves.

advantageous in a frequently shifting environment (i.e., one repeatedly prone to the advance and retreat of massive glaciers).

Oak lumber is prized for a number of different uses, including furniture, firewood, and construction timber. White oaks in particular produce small balloons (called tyloses) in their inactive vessels to restrict water flow and prevent the spread of pathogens. This makes their wood incredibly leak proof, hence why white oak is the choice species used to make wine barrels and ship hulls. Red oak is the number one timber species harvested at GMF. It is no coincidence that the bulk of harvesting at GMF occurs along the Number Four Trail, where red and white oak grow most abundantly, or that the prescriptions themselves are specifically tailored to promote the regeneration of oak seedlings.

### Eastern White Pine (*Pinus strobus*)

Tall coniferous trees with flakey bark plates and branches growing in whorls up the trunk. The only representative of the sugar pine group (subgenus *Strobus*) in the eastern United States, with needles in packets of 5 and long, slender cones.

The eastern white pine grows prolifically in a variety of habitats, most notably sandy outwash soils and rich former agriculture sites.



Classic stand of GMF old field white pine.

Huge trees were once abundant throughout this region, but centuries of harvesting have reduced its size and importance within forest mixtures. Indeed, the old growth white pines were once the tallest trees in the eastern deciduous forest, frequently attaining heights over 200 feet. English settlers made quick work of decimating these giants, using the timber for a variety of uses, whenever it was available. The tall straight trunks were particularly useful as ship masts—a welcome development for the English fleet, which had theretofore been reduced to splicing several smaller trunks together due to their severe timber famine. Though there are many large individuals in places like GMF today, they pale in comparison to the magnitude of their old growth ancestors.

White pine has special significance at GMF as an early invader of old pasturelands. The shade intolerant seedlings are especially adept at competing with the grasses of abandoned fields and forming dense monoculture stands. GMF is dotted with many such sites today, mostly



Needle detail. Species in the white or sugar pine group have five needles per packet, unlike those of the yellow pine group that have two or three.



Multi-trunked white pine, resulting from pine weevil damage at a young age.



LEFT: Black birch, growing atop a decaying stump.  
 RIGHT: Paper birch, starting to show the papery, peeling bark that distinguishes it from Gray birch, once grown to a certain age.



Yellow birch, sporting Chaga fungus.

on the Canaan side. They were among some of the earliest harvests done at GMF in the 1940s, and are still managed today in some instances (see Forest Management Sites 5: White Pine Thinning).

These densely packed old-field stands are often prone to attack by the white pine weevil (*Pissodes strobe*). This insect preferentially feeds on the dominant shoots of trees, causing them to grow multiple trunks. Aside from making trees non-merchantable as timber, the multi-trunked growth form makes the adult trees more susceptible to damage from snow loading and windthrow.

### Birches (*Betula* spp.)

Fast growing trees with waxy, often papery bark. Twigs with fat buds arranged in a distinctive zig-zag pattern, aromatic when snapped. Leaves simple, often egg shaped, with many teeth. Four species occur at Great Mountain Forest, varying in abundance:

**Black Birch (*Betula nigra*):** Dark bark, breaking into thin plates on older trees.

**Yellow Birch (*Betula allegheniensis*):** Yellowish, thin papery bark that peels off in shaggy strips.

**Paper Birch (*Betula papyrifera*):** White, papery bark that peels off in sheets.

**Gray Birch: (*Betula populifolia*):** White to pale gray bark, non-peeling, usually a smaller tree than the other species, with distinctive aspen-like drooping tip leaves.

As a group, the birches are strongly associated with the northern hardwood forest, often occurring in mixtures alongside hemlock and beech. With a fast growth rate and copious wind dispersed seeds, birches are aggressive colonizers in newly opened growing spaces. They also make good toothpicks and tongue depressors because the wood is flavorless. Occasionally, well formed individuals are used to make veneer paneling.

The four birch species of GMF are mesic loving species (yellow birch slightly wetter, black birch slightly drier), and as such are spatially partitioned in the forest according to their relative tolerances to shade. Gray birch is the most shade intolerant, followed by paper birch, yellow birch, and black birch. Since so much of GMF is now later successional forest, it makes sense that the relatively shade tolerant black birch is by far the most common species. The growth shoot is very sensitive to light, and the tree will twist and grow crooked through dense hemlock stands in order to break through to the canopy.

Chaga (*Inonotus obliquus*), a canker forming fungus, occurs exclusively on species in the birch genus. Though not exceedingly common, it can often be found growing on trees at GMF. The species is used to make a medicinal tea in Eastern European folk medicine, said to be effective in reducing inflammation, inhibiting tumor growth, and even extending the human lifespan.

### Maples (*Acer* spp.)

A varied genus of trees, united most visibly by their trident shaped, lobed leaves, and samara fruits (“helicopter seeds”). Three species occur commonly at the Great Mountain Forest:

**Sugar Maple (*Acer saccharum*):** Smooth, gray bark on saplings turns corky at the pole size, then deeply and irregularly plated and furrowed on larger trees. Leaves are 5-lobed with intermittent teeth around the edges.

**Red Maple (*Acer rubrum*):** Similar bark to sugar maple on young trees, but plates on older trees are shaggier and composed of papery layers. The bark develops a distinctive target-shaped canker in later years. Leaves vary dramatically by region across its wide range, but tend to be small relative to others in the *Acer* genus, usually with reddish leafstalk and three main, coarsely toothed lobes.

**Striped or Moose Maple (*Acer pensylvanicum*):** A small tree relative to the other two maple species at GMF. Bark is distinctively smooth, in green, gray, and orange stripes running horizontally up the trunk. Leaves are very large with three main lobes and many fine teeth along the margins.

These three maples vary widely from one another in regard to ecology and growth form (as opposed to the more internally homogenous oak and birch genera). The striped maple is a small understory tree that thrives in rich, cool, moist sites (seen frequently on the Sam Yankee Trail). Sugar maples can be massive trees, existing primarily on well drained mesic soils in slopes and uplands. Red maple is a study in broad ecological amplitude—it lives handily in a variety of extreme environments throughout GMF, from acidic bogs and swamps to excessively well drained rocky outcrops. All are fairly shade tolerant, particularly the sugar maple which is roughly on par with American beech and hemlock.

Of the three species, sugar maple is by far the most commonly



LEFT: Mature sugar maple, featuring irregular, plated bark.

RIGHT: Red Maple bark detail.

utilized, though red maple is sometimes used for flooring, but it is highly prized for a number of products. Among the many commercial uses for its lumber is the backing for wooden musical instruments, often favored for the “bird’s eye” grain in some individuals. Though rarely co-occurring in the forest, for hundreds of years maples and red spruces have been fused together as the main body components of violins. The spruce is used as the front and sound post for its resonance qualities, while the maple forms the back and fingerboard for structural integrity.

Sugar maples are also the primary species used in the production of maple syrup. Many early New England farmers would leave a few large trees near their houses for the purpose of sap collection in the late winter. Many of these legacy trees are still around to mark former homestead sites, grown twisted and gnarled with open grown characteristics. Many sites at GMF are managed exclusively for promoting the growth of sugar maples for sap production (see Forest Management 8: Maple Sugaring Operations).



American beech inflicted with beech bark disease. The normally smooth gray bark becomes pocked with holes and fissures as the fungus spreads through the tree's vascular system.

### American Beech (*Fagus grandifolia*)

Tall and with massive trunks, the American beech is atypical in the eastern deciduous forests for its completely smooth, light gray bark. In most other tree species in this area, the cracking of bark into distinctive plates, shaggy strips, or shingles is thought to help dissipate heat from sunlight



American beech, bark and leaves.

more readily by exposing bark units with smaller surface areas. This need is particularly pertinent during the winter months, when there are no leaves to block the path of sunlight to the bark. Since it lacks modeled bark, American beech it is thought that it accomplishes heat dissipation by producing light colored bark, which reflects more sunlight. Another theory suggests that since beech is of tropical origin, the smooth bark may have discouraged the growth of epiphytic plants from growing up the trunk.

American beech is extremely shade tolerant, roughly on par with eastern hemlock and sugar maple. The egg shaped leaves are pointed, with an overall more rounded shape and less distinctly pronounced teeth than the related American chestnut. Hanging dead leaves are often retained on branches throughout the winter, which is another key feature for identification.

Beeches are common at GMF, growing often in rich, well drained soils. The species is a key constituent of the northern hardwood forests, co-occurring frequently with hemlocks. A prolific stump sprouter, American beeches often grow in dense clonal thickets, particularly in former harvest ve more desirable timber species like oaks a chance to regenerate is a prime concern of GMF foresters.



Coppiced shagbark hickory.

Beech bark disease is another entry in the growing list of tree afflictions. The beech scale insect *Cryptococcus fagisuga* was accidentally introduced to Nova Scotia in 1890, and it has subsequently spread across eastern North America. Young larvae feed on beech phloem by piercing the bark with their strong stylets. The holes they leave behind serve as a vector for two species of airborne fungi (*Neonectria faginata* and *Neonectria ditissima*) which invade the tree and kill it slowly. Though not yet spread everywhere at GMF, there are many areas where the disease is abundant, such as along the Charcoal Pit Trail on the northeastern side.

### Hickories (*Carya* spp.)

Trees with hard wood, crooked twigs, and alternate, pinnately compound leaves. Two species are the most common at GMF: Shagbark Hickory (*Carya ovata*): mature bark in strikingly shaggy strips, unmistakable for any other tree species. Leaves usually with 5 broad leaflets. Pignut Hickory (*Carya glabra*): mature bark in tight interlacing ridges, like a less deeply furrowed ash. Leaves usually with 5-7, skinny leaflets.

The hickories at GMF are almost always relegated to dry hilltops and well drained talus slopes, often co-occurring with Pennsylvania sedge (*Carex pennsylvanica*) and hophornbeam (*Ostrya virginiana*). Though not often harvested at GMF, the extremely hard wood has extremely high thermal output as a firewood. Other historical uses include door hinges, cabinetry, hardwood flooring, and barrel hoops—pretty much anything that needs to serve as a solid fastener. The lipid-rich nut masts are a major food source for many forms of wildlife, and can be eaten by humans as well—the closely related pecan (*Carya illinoensis*) being the most commercially popular today.

### Hay-Scented Fern (*Dennstaedtia punctilobula*)

This plant is a small woodland fern, regularly growing only about 50 cm tall. The fronds have small, twice divided feathery leaflets, distinct from the many other fern species at GMF by the fact that they grow singly instead of centered in clumps. When in doubt, try crushing the leaves and



Hickory nut husks.

giving them a smell—the scent of damp hay confirms identification, as the common name would suggest.

Though native to the region, hay scented fern is extremely effective at impeding forest regeneration for long periods of time. Spreading quickly via spores and underground vegetative growth, the fronds spread rapidly in light opened areas, browsed by no herbivore, unlike the unfortunate tree seedlings of which are often fond forage. Though such a site appears verdant with its thick carpet of vegetation, it is in fact in a state of suspended forest development. GMF forester Jody Bronson refers to it as “The Great Green Lie.” Places to see hay scented fern in abundance include recent harvest sites, such as the NRCS Bird Habitat Cut (Forest Management 9).

### Eastern Newt (*Notophthalmus viridescens*)

The prototypical newt species of New England, with three life stages. In the aquatic larval stage individuals are long and brown, with distinctive red feathery gills. During the red eft stage (most commonly seen)



An ocean of hay-scented fern on the Sam Yankee Trail.

the eastern newt lives on land, and has bright orange skin with up to 21 dark spots. In the final phase, adults return to the water, growing a larger tail for movement and turning an olive-green color.

The eastern newt is by far the most common amphibian at GMF and the broader eastern region. It is thought that the land stage allows for outcrossing between ponds, ensuring greater genetic diversity. Preferring moist, muddy environments as they traverse the long distances between wetlands, flushes of newts can be seen out wandering after rain events. In the wet springtime, small ruts and drainage ditches on Chattleton Road and the Number 4 Trail create small ephemeral micro-wetlands in which the young larvae of newts and other amphibian species can flourish.

### Moose (*Alces alces*)

The moose is the largest herbivore in Great Mountain Forest. Massive antlers are a distinctive feature, which can spread more than 6 feet across. The broad hooves serve to distribute weight evenly on snowy or muddy ground. The dangling flap of skin on the neck is called a bell, and is



Eastern red newt during the red eft stage, when it lives on land.

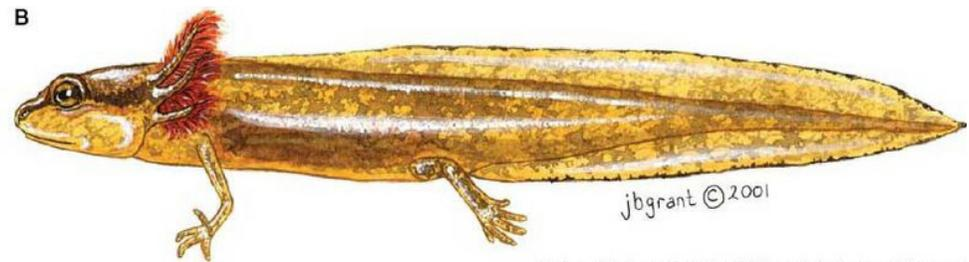

Eastern Red-spotted Newt (*Notophthalmus viridescens*)

The larval stage, with distinctive reddish gills.

of unknown utility.

Moose are more closely associated with a northerly range, and have only become common at GMF in recent years. Evidence of their habitation is common in marshy or swampy wetlands, where the tall forage means the tall creatures do not have to bend down so low to feed. Most often this evidence comes in the form of droppings or antler rubbing high on trees, as adult individuals tend to avoid humans, and can move nimbly when it is required. Occasionally, GMF staff have been able to photograph moose at long distances, or get close up shots by setting up motion sensor cameras at strategic locations in the forest.

Several studies, formal and informal had been established at GMF



Young trunk with distinctive antler markings.



A moose seen wandering in a recent GMF harvest site.



A tuft of moose hair found at GMF, likely shed as the result of fighting between two bulls.

to study how their introduction to the environment may impact the local forest ecosystem (see Forest Management 4: Wapato Lookout, and Research Sites 1: Moose Enclosure). Preliminary results show that moose do exert a strong influence on understory regeneration, which may have a bearing on forest management practices moving forward.

### **White-tailed Deer (*Odocoileus virginianus*)**

A medium sized deer species, abundant throughout the eastern two-thirds of the United States. Stocky and nimble creatures, covered in a reddish brown coat that turns grayish towards the winter time, while the tails are a distinctive bright white below. Young fawns have distinctive white spots (a la Bambi). Adults frequently weigh around 100 pounds, but can exceed 150 in certain areas.

Deer are present throughout Great Mountain Forest, with ample evidence from scat and rubbing and herbivory damage on young trees. Their proliferation across the broader landscape is likely related to the extirpation of major carnivorous predators from the region, most notably gray wolves and cougars. Damage from herbivory in particular can

dramatically inhibit the ability of forests to regenerate, promoting scrubland that may be beneficial to other animal groups. A study at GMF by students from the Yale Forest School investigated the impact of deer rubbing on young trees (Lutz and Chapman 1944). More recent deer research at GMF (Tripler and Canham 1998, Tripler et al 2002, Tripler et al 2005) focuses on the impacts of deer herbivory on a variety of ecosystem drivers, including nutrient availability and forest succession.

GMF currently permits hunting on the property in the fall. The forest is delineated into hunting zones, and hunters are asked to fill out wildlife observation sheets on anything they see while stationed in a particular zone. It is a clever approach to collecting broad sets of data on the abundance and distribution of different creatures in GMF.

### **Black Bear (*Ursus americanus*)**

The black bear is the most abundant bear species on Earth. Once completely extirpated from the New England region, black bears have made a modest recovery, living in sparsely populated forest regions like GMF. They prefer to live in dense woodlands on inaccessible features,



Deer at GMF showing spring coat coloration.



White oak showing evidence of bear claw marks.

which GMF has in abundance. Such sites also tend to contain greater abundances for masting tree species such as oaks and hickories and hardy low bush blueberries, which constitute a major portion of their diet. In our wanderings at GMF, we frequently saw evidence of bear habitation near the crest of high elevation balds, such as Collier's Cliff south of the Yale Camp (see Natural Communities 4: Balds and Rocky Outcrops).

Great Mountain Forest was part of a statewide PhD research study led by Michael Evans of the University of Connecticut, whose goal is to track and map the distribution of black bears across the state. Hair corrals are strategically set up throughout the forest to (harmlessly) catch tufts of fur from bear passerby. By analyzing the DNA in these hairs, the researchers can track the movement patterns of the bears from other hair corrals they have set up throughout Connecticut.



A mama black bear and her cubs, exploring one of the GMF hair corrals. This photo was captured via motion sensor camera, strategically set up to view the plot.



Black bear spotted wandering close to the GMF Forestry Office.

### American Beaver (*Castor canadensis*)

Beavers are the ancient water-dwelling ecosystem shapers of GMF. Though North American beavers are of modest size today, fossils of their giant beaver progenitors (*Castoroides ohioensis*) frequently measure in at 1.9 meters in length, and up to 2.2 meters in height. Beavers were the most aggressively sought after species in the early fur trade. Increased pressures from overhunting, coupled with their naturally low reproductive rates, led to their elimination from southern New England by 1660, and near extirpation from the continent.

Today, beavers are rebounding throughout the region, once again shaping entire ecosystems with their dam-building affinities. To learn about the importance of these unique natural communities at GMF, please see Natural Communities 11: Beaver Ponds.



An eagerly gnawing beaver, standing in the shallows of Wapato Pond.

### **Wild Turkey (*Meleagris gallopavo*)**

Like many of the preceding creatures, turkeys were once functionally exterminated from the New England landscape. Unlike them, however, the wild turkey has been the subject of many reintroduction attempts by humans, usually with poor results. The released individuals tended to be farm-raised turkeys, who did not fare well on their own. One of the first successful efforts in Connecticut to naturalize game turkeys was actually conducted at GMF in 1975. The large, contiguous, sparsely populated forest was just what the turkeys needed to flourish.

A research report was later conducted at GMF by the state Department of Environmental Protection to determine how turkey populations were faring throughout Litchfield County, Connecticut (Hussein 1979). They employed mark and recapture techniques with radio transmitters to track flock movements, and conducted a census by soliciting sighting reports from various other state agencies and the general public. After 5 years of study, the researchers concluded that populations, though still small, were at last steadily increasing in the region. Today, of course, turkeys are a common sight when driving through Connecticut, often roaming in flocks through woodland meadows.



GMF turkeys, now abundant and strutting their stuff. This photo was captured via motion sensor camera, placed along the trail.

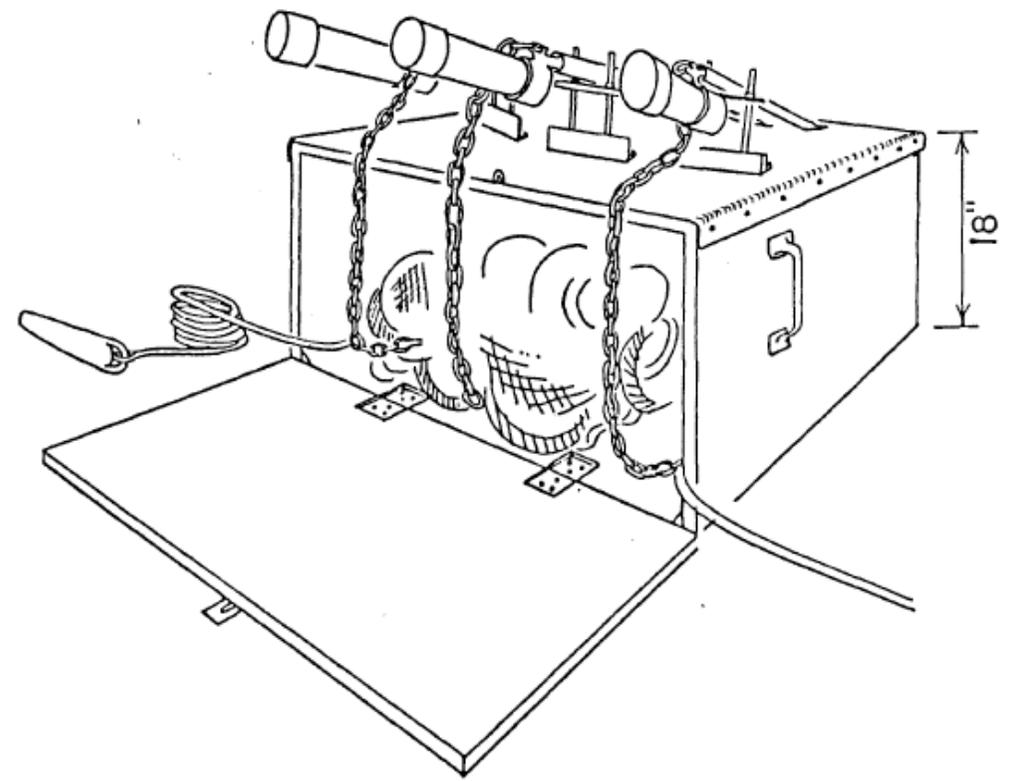
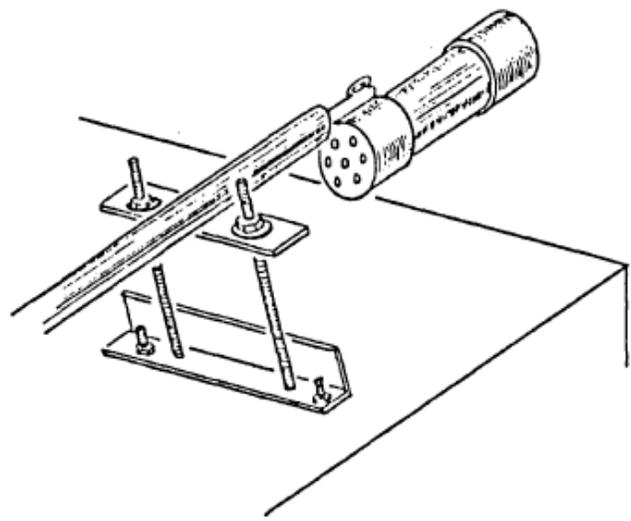
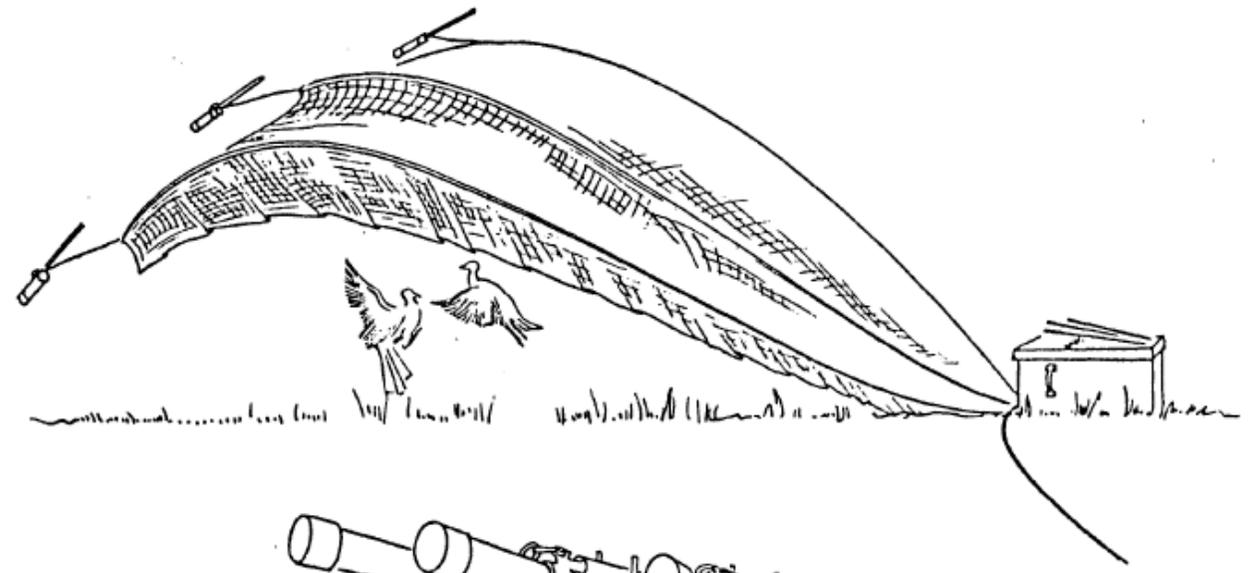
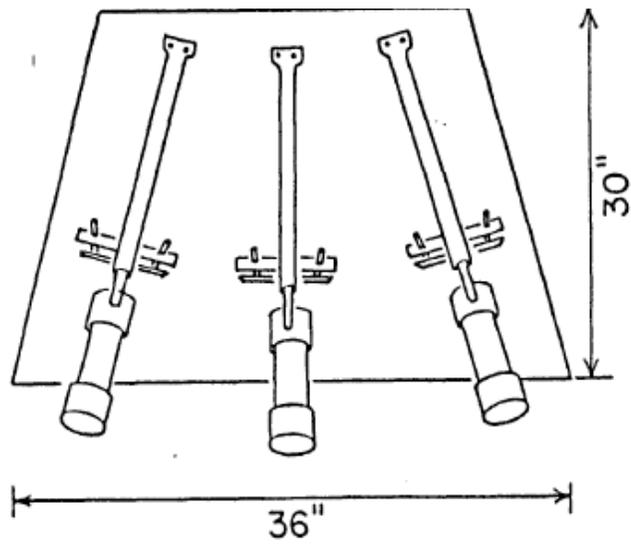
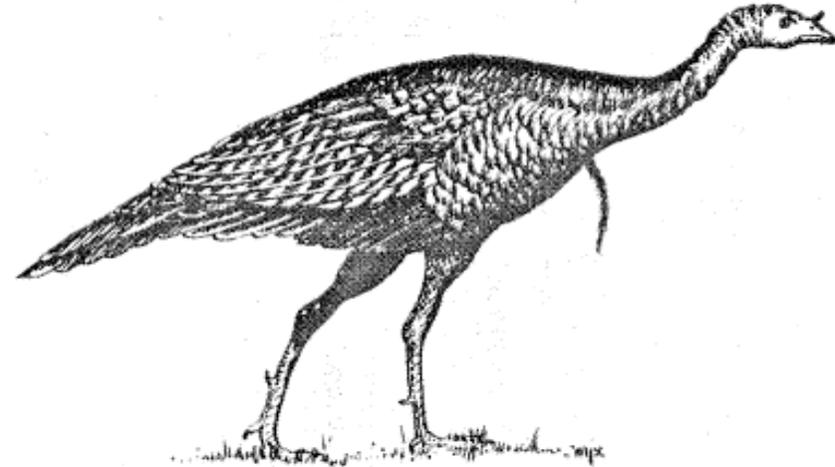

Figure from the turkey reestablishment study, conducted at GMF (Hussein 1979). Above is a schematic detailing the mechanics of the study's box rocket net apparatus, used to capture turkeys for banding and future study. Despite the impressive design, only a few dozen turkeys were caught in this way throughout the five year study. As noted in the published paper: "Poor results were mainly due to poor net construction, which allowed turkeys to escape from the net, in the first year. Malfunction of the propellant, caused by moisture condensation or extremes of temperature, also reduced success."

## Resources

- Hussein, A. (1979). *The reestablishment of the eastern wild turkey in Connecticut*. Department of Environmental Protection Research Report, State of Connecticut. 48 pp.
- Lutz, H.J. and H.H. Chapman (1944) *Injuries to young tree trunks from antler rubbing by deer*. *Journal of Wildlife Management* 8: 80-81
- McShea, W.J. (1997). *The Science of Overabundance: Deer Ecology and Population Management*. Washington, DC: Smithsonian Institution Press.
- Peattie, David Culross (1966) *A Natural History of Trees of Eastern and Central North America*. Houghton Mifflin Co., Boston
- Sibley, David Allen (2009) *The Sibley Guide to Trees*. Knopf Books, New York.
- Smith, Winston Paul (1991) *Odocoileus virginianus*. *Mammalian Species* 388: 1-13
- Tripler, C.E., and C.D. Canham (1998) *Neighborhood effects of canopy tree species on sapling nitrogen contents: implications for foraging patterns by white-tailed deer*. *Ecological Society of America, 83rd Annual Meeting, abstracts*.
- Tripler, C.E., C.D. Canham, R.S. Inouye, and J.L. Schnurr (2002) *Soil nitrogen availability, plant luxury consumption, and herbivory by white-tailed deer*. *Oecologia* 133: 517-524
- Tripler, C.E., C.D. Canham, R.S. Inouye, and J.L. Schnurr (2005) *Competitive hierarchies of temperate tree species: interactions between resource availability and white-tailed deer*. *Ecoscience* 12: 494-505

# WANTED



INFORMATION LEADING TO THE ARRESTING STUDY OF THE INNOCENT WILD TURKEY. (NOT THE HUMAN TYPE) IF SIGHTED PLEASE FILL IN THIS CARD AND SHOOT IT INTO A U.S. MAIL BOX. YOUR REWARD IS OUR THANKS!

LOCATION \_\_\_\_\_

DATE \_\_\_\_\_

TIME \_\_\_\_\_

NUMBER SIGHTED: \_\_\_\_\_

ACTIVITY: \_\_\_\_\_

MALES \_\_\_\_\_

NESTING \_\_\_\_\_

FEMALES \_\_\_\_\_

ROOSTING \_\_\_\_\_

YOUNG \_\_\_\_\_

FEEDING \_\_\_\_\_

Figure from the turkey reestablishment study, conducted at GMF (Hussein 1979). Picture of the postcard that was mailed to residents in the region of study with the aim of conducting a census of wild turkey populations.



# FIELD MARKS

OF GREAT MOUNTAIN FOREST

When we identify a bird, we typically look for field marks such as wing bars and eye stripes, or behaviors such as tail-bobbing. These features help us identify the species of bird and learn more about it. By looking for field marks of a landscape, we can learn to identify the history or factors shaping that landscape.

Following is a guide to field marks of GMF's landscape. By learning to interpret these features, one will understand the landscape and history of GMF more completely. Each field mark contains a photo and brief description as well as suggestions for further exploration in the document, and by extension GMF. This guide is meant to also serve as a stand-alone piece that can be given to GMF users to enrich their experience.

## **COPPICED TREES**

Coppiced trees are those that were once cut and subsequently re-sprouted. When a stump re-sprouts it sends dozens of stems up from the outer ring of the stump. Over time, the stems compete and typically two or three stems remain. A larger stump, or one that has been coppiced many times, will have more trunks. In GMF most of the coppiced trees are red oaks cut during the charcoal days of the late-1800s. Fire can also cause a tree to coppice. See the Land Use section.

## **LEGACY TREE**

Legacy Tree, also known as “wolf trees,” typically have larger diameters, spreading horizontal branches, and complex form that surrounding

forest trees lack. Such trees grew for some time in an open setting, typically a pasture. Full sun allowed them to grow “out” as well as “up.” In GMF legacy trees are often sugar maples, and sometimes oaks, black cherry, and others. In pastures they provided shade for livestock. Today they provide structure for wildlife. See the Dorman site for more.



Coppiced trees at Great Mountain Forest.



Legacy tree at Great Mountain Forest.

## OLD TREES

Old trees can be identified by their size, bark characteristics, and the shape of the upper branches. At left is an old growth white oak. It is not large, but the sinuous trunk, wavy and truncated upper branches, and smooth basal bark (not visible here) identify it as a tree over 250 years. At right, an old growth hemlock tree is identifiable by the green crustose lichen on the bark. This occurs only on hemlocks 300 years or older. See the Old Growth section in Natural Communities for locations and description.





## OLD FIELD WHITE PINE

Old-field white pine stands occur on abandoned pastures and crop fields of GMF. Stands dominated by even-aged white pines with lots of dead branches on the trunk of the tree indicate trees having grown in the open. Often, some trees will split into two or more trunks, a result of the white pine weevil. The lower portion of the Stoneman Trail, the old Norfolk Downs, and other areas around the edges of GMF contain old-field pines.



## PLANTATIONS

Plantations of exotic and some native species occur in GMF. Plantations were established in the 1940s and 1950s on (then) recently purchased agricultural lands, taking advantage of ready ground and abundant sun. This image, of a Norway spruce plantation along the Jean Trail, contains a stone wall from the agricultural days. Plantations, unlike a forest, typically have little diversity. Plantations can be found along Chatteleton Road and GMF lands nearer to Norfolk.

## GIRDLED PINE

Girdled pines occur in several plantations and naturally seeded white pine stands in GMF. A forester intentionally killed these trees because they had poor form, were an undesirable species, or were utilizing space the forester wanted for something else. Here, the white pine was girdled to make way for a Norway spruce plantation. The tree could have been cut and removed, but girdling it leaves a standing dead tree – excellent for wildlife. Note the X on the trunk. See the Dean Farm on Jean Trail site and Stoneman trail for examples.



Girdled pine at Great Mountain Forest.



Early successional stands at Great Mountain Forest.

## EARLY SUCCESSIONAL STANDS

Early Successional stands occur where there has been recent disturbance, such as timber harvesting, or abandonment of open land. The small diameter, even-aged trees indicate they all came up together. In this stage, as in the photo, the trees are growing rapidly in competition for sun. Most trees will die, being excluded from the canopy by more vigorous trees. Typical early successional species include paper birch, black cherry, black birch, and oaks. See Norfolk Downs in the Land Use section.

## STONE WALLS

Stone walls are common at GMF mainly along the settlement roads (Chattleton, Meekertown). They indicate agriculture from plowing or pasture. Most walls were fences, built to keep animals in or out of an area. Large stones comprise such wall and typically had a rail on top. Field walls, comprised of small and large stones, occur where stones were removed from a field for crop production. There are over 5-miles of wall in GMF. See Dorman site, Southwest Stone wall site. Each has over a mile of wall.



Stone wall at Great Mountain Forest.



Clearance cairn at Great Mountain Forest.



Cellar Hole at Great Mountain Forest.

## CELLAR HOLES

Cellar holes are occasionally found in GMF and are most often located near the roads. Cellars served as foundations for houses and doubled as cool storage for food. The Chatleton, Meekertown, and #4 roads all have cellar holes. Some cellars are well-preserved, while others are barely discernable beyond a depression in the ground. Examples of cellars can be found at Potter's corners, Dorman, Mansfield and others in the Land Use section.

## CLEARANCE CAIRNS

Clearance cairns result from the removal of stones in agricultural fields. Instead of being moved to a fence or wall, the stones are typically placed on top of a larger, unmovable stone. Clearance cairns occur in both crop fields and pastures. Often, the stones are later moved (in winter) to a wall or fence. In GMF clearance cairns often contain only a few stones. Most of the settlement sites contain cairns. The Dorman, Dean, and Mansfield sites contain several.



Stone wall at Great Mountain Forest.

## CHARCOAL HEARTHES

Charcoal hearths are abundant in GMF with perhaps a few hundred scattered around the forest. The smooth, flat ground in a ~30-foot diameter circle, etched into a hillside makes them unmistakable. Digging through leaf-litter on the edges often reveals charcoal. The flat area is typically devoid of vegetation due to soil chemistry changes. Typically, the hearths are clustered, with several in close proximity to each other. See the Land Use site for Charcoal hearths.

## COLLIER FIREPLACES

Collier Fireplaces are rare finds in GMF. This one is in excellent condition, where as most have collapsed and are being taken over by trees and shrubs. The fireplace shown here is of typical construction. Around this, a hut made of wood and bark was built for two colliers. For two weeks they would watch over the hearths located a short distance from the hut.



Collier fireplaces at Great Mountain Forest.



Barbed-wire fence at Great Mountain Forest.

## BARBED-WIRE FENCES

Barbed-wire fences are relatively uncommon throughout most of GMF. Like stone fences, they were strung to keep animals in or out of an area. Barbed wire was invented and popularized in the 1870s. Prior to that, if a fence occurred it would have been wooden or stone. Barbed wire can be found along the Jean Trail and the Dorman site, among a few other areas.

## SMOOTH GROUND

Smooth ground, as seen here, is an important field mark found around old settlements in GMF. Forests that have never been cleared will have lumpy and bumpy ground as a result of falling trees moving soil, and from rocks. When the ground is smooth, even if on a slope, it indicates past land use and clearing. The site pictured here was pasture about 80-years ago. In GMF sites with old field pines, plantations, or stonewalls also often have smooth ground.



Smooth ground in Great Mountain Forest.

## ROCKY GROUND

Rocky ground, shown below with boulders, in addition to its glacial legacy, often occurs on sites that have never been opened to agriculture. Talus slopes and boulder fields were occasionally grazed, but they often remained wooded. See Talus Slope in Natural Communities.

## BEDROCK

Bedrock at the surface indicates shallow soils and sites that may have been over-grazed, or burned and the soil eroded. Often bedrock is not clearly visible, but bald or barren communities dominated by low-bush blueberry, grasses, haircap mosses, or *Cladonia* spp. lichens (seen here) will dominate. Some lichen communities can be 200 years old. Smooth rounded bedrock is also an indicator of glacial activity. See Balds and Rocky Outcrops in the Natural Communities section.



Rocky ground with boulders.



View of bedrock in Great Mountain Forest.



Carpet of Canada May-flower.

## CANADA MAY-FLOWER

Canada May-flower (*Maianthemum canadense*) carpeting the ground as seen here is a good indicator of previous pasture at GMF. It is a woodland flower that prefers acidic, slightly dry sites, and also dominates now-forested old fields. Here it is seen with a stand of old field pines. While birds and mammals disperse the seeds, on old-field sites reproduction by rhizomes is common.

## JAPANESE BARBERRY

Japanese Barberry (*Berberis thunbergii*) emerging in an old field white pine stand in GMF. Japanese barberry is perhaps the most widespread exotic invasive in GMF. Its presence indicates old pastures or agricultural lands. Unfortunately, barberry was often planted as part of early efforts for promoting turkey habitat. The toxic foliage and thorn-covered twigs are not eaten by deer or moose.



Japanese barberry.

## APPLE TREES

Apple trees (*Malus domestica*) are not native to North America. Their presence in the forest indicates previous settlement even when other signs of habitation such as a cellar hole may be absent. Unlike other exotic species, apples rarely reproduce in the wild. They offer excellent food resources to animals so are considered desirable features for forest management.



Apple tree in Great Mountain Forest.



## **SITES OF INTEREST: GEOLOGIC AND GEOMORPHIC SITES**

Although the thrust of this project lies in the forest, several sites in Great Mountain Forest are noteworthy for their geological and/or geomorphological interest. As discussed in the first section of this book, the biological and cultural landscapes refer back to geology. That is, the distribution of plant communities and thus fauna is driven in large part by geology. Similarly, the cultural landscape and the places and ways people have made habitat from the land is driven largely by geological history.

These sites bring people to the places we identified during our field inventory. Undoubtedly, additional significant sites exist, waiting to be discovered and interpreted. The sites span the very simple (bedrock sites) to the more complex (Glacial Lake Norfolk). Use these as a launching point for understanding geology and uncovering the ways rocks and landforms drive our ecosystems and our history.

## PHYSICAL LANDSCAPE 1: BEDROCK

### Summary

In some landscapes bedrock can be difficult to find. Deep soils and vegetation obscures the geologic story. But at Great Mountain Forest, bedrock is common, accessible and observable. These bedrock exposures show not only the specific rock type, but also the glacial history through weathered polish.

### Access

See specific sites below.

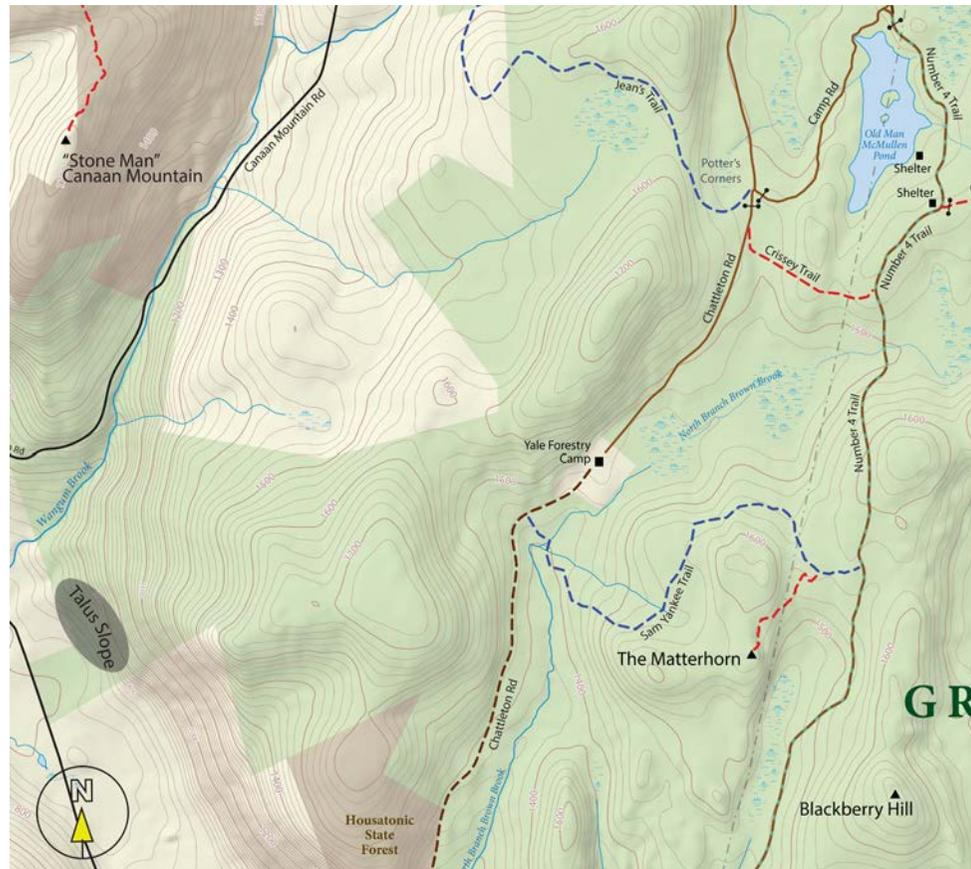

Locator map for bedrock sites listed at left. Numbers (1-4) refer to specific listed locations.

### Specific Location

1. *The Matterhorn*: 41°56'33.89"N; 73°15'20.82"W
2. *Stoneman Summit*: 41°57'27.20"N; 73°16'57.43"W
3. *Blackberry Hill*: 41°56'16.06"N; 73°14'59.65"W
4. *Talus Slope*: 41°56'33.69"N; 73°16'52.74"W

### Comparative or nearby sites

See Rocky Outcrop balds in Natural Communities.  
Stoneman: See Stoneman Summit in this section.  
Blackberry Hill: See Oak-Hickory Woodland in Natural Communities.  
Talus Slope: See Rich Talus Slope in Natural Communities

### Description

The sites listed here suggest a few of the many places in GMF where bedrock is exposed. These sites display extensive areas of exposed bedrock. But walking in the woods and especially on the ridges, bedrock



Bedrock section of Canaan Mountain Schist on the Matterhorn at GMF.

occurs frequently. Glacial polish, now 16,000 years weathered, occurs and demonstrates that aspect of GMF's story. The Talus Slope does not contain actual bedrock, but very large boulders including a few slabs of Stockbridge Marble. See also the Appalachian Forest site in Natural Communities for an additional marble boulder. Marble exposures are rare in GMF.

### Visible Layers Include:

- Upper and lower slice of Canaan Mountain Schist (highest layers; most of GMF)
- Large blocks of Stockbridge Marble or Walloomsuc Schist (lowest layers)
- Gneiss of the Housatonic Massif (should be visible in the far south of GMF).

### Importance

Bedrock geology sets the foundation for the biological and the cultural landscapes. Though GMF generally has low geological diversity, a few different rocks types can be found. See the Geological Underpinnings section above for GMF geology.

### Research Questions

How does the presence of bedrock (shallow soils) shape plant communities?  
How does primary succession differ in various bedrock environments?

### Resources

*See resources in section 1 for Geologic Foundations.*

## PHYSICAL LANDSCAPE 2: GLACIAL LAKE NORFOLK

### Summary

The site contains glacial deposition features in the area of postglacial Lake Norfolk. Toby Pond, Toby Bog, and kettle, kame, and moraine glacial deposits around the old Norfolk Downs golf course comprise areas of significant glacial deposition in/near GMF.

### Access

Access from Tobey Pond. Some areas are not identified as GMF lands on maps. Inquire at GMF Office.



Location of Glacial Lake Norfolk as described here. For map of glacial features see next page.

EXPLANATION	
<b>Ice-dammed Glacial Lakes</b>	
ln	Glacial Lake Norfolk
lcw	Glacial Lake Cornwall
lho	Glacial Lake Hollenbeck
ld	Glacial Lake Danbury
lpt	Glacial Lake Pootatuck
lw	Glacial Lake Winsted
lnp	Glacial Lake Nepaug
lbr	Glacial Lake Bristol
log	Glacial Lake Coginchaug
lma	Glacial Lake Manchester
lsb	Glacial Lake Salmon Brook
lrb	Glacial Lake Roaring Brook
lc	Glacial Lake Colchester
lex	Glacial Lake Essex
lon	Glacial Lake Oneco
lvo	Glacial Lake Voluntown
lp	Glacial Lake Pachaug
<b>Sediment-dammed Glacial Lakes</b>	
	Glacial Lake Connecticut
	Glacial Lake Middletown
	Glacial Lake Hitchcock
lg	Glacial Lake Great Falls
ll	Glacial Lake Lime Rock

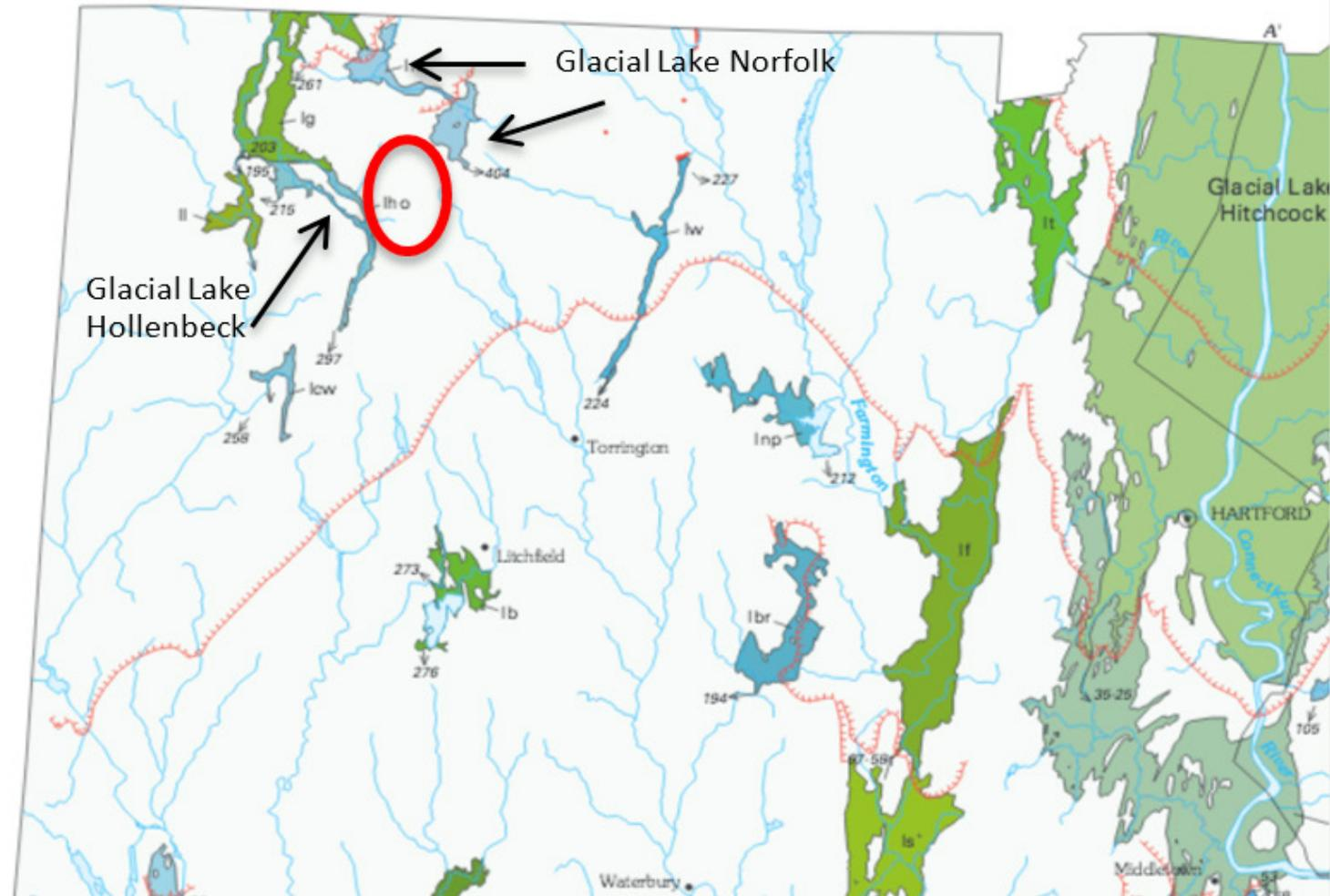

Map of glacial lakes in Connecticut by Stone et al. (2005) here cropped to show only NW Conn. Great Mountain Forest approximately shown with red circle. Ice margin (dam) in red shown for Lake Norfolk.

### Specific Location

1. *Tobey Pond*: 41°58'34.10"N; 73°13'04.10"W: Town beech.
2. *Tobey Bog*: 41°58'42.20"N; 73°13'32.14"W: Ice margin deposit occurs opposite the road from trail entering the bog.
3. *Norfolk Downs*: 41°58'43.14"N; 73°13'5.77"W: this point occurs on the crest of an ice margin deposit shown as red line in the map above.

### Comparative or Nearby Sites

The Norfolk Downs golf course, in the land use history section, details its history. Tobey Bog is described in the Natural Communities section.

### Description

Approximately 15,500 years ago, the basin that is today Norfolk Village was an ice-dammed glacial lake. Its presence was likely fleeting, lasting only from when ice melted in the basin until the ice dam to the north collapsed. Nonetheless, it was long enough to deposit sorted lacustrine

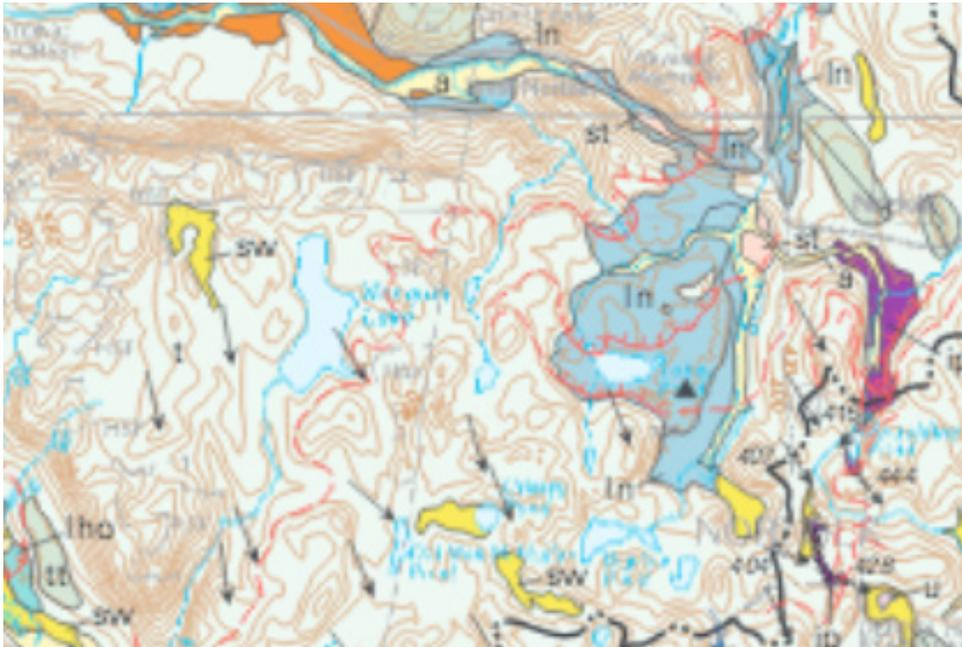

Glacial geology map from USGS. Light blue area in center-right is Glacial Lake Norfolk. Tobey Bog is slightly northwest of the pond. Red lines with ticks show ice margin positions from the outer edge of the glacier. The landscape to the north and east of Tobey Pond is undulating glacial sediment with kames, kettles, and ice margin deposits. The black arrows show direction of glacial travel. See *Geological Underpinnings* for description of surficial geology.

sediment, ice margin deposits, and shape the land.

Without a close examination of the soils and sediments of the area, a complete description is hypothetical. Warren (1969) described the site in some detail. Nonetheless, it is clear walking this area, with short steep ridges and undulating topography, that significant glacial and lacustrine deposition has occurred.

Glacial Lake Norfolk formed as the ice retreated, dammed to the north by the ice itself (Ice margin) and to the south by the watershed divide. It can be seen on the USGS map above. In this area small tributary streams of the Blackberry River flow north, opposite direction of that of the ice. The streams flowed north, bringing sediment from deposits in the recently deglaciated landscape. The glacial deposits are composed of sands, pebbles and gravels. Tobey Pond Delta formed from the input of these riverine sediments into Glacial Lake Norfolk. The sediments buried a chunk of ice on the margin of the lake, and when that melted, Tobey Pond Kettle was formed.



The undulating kettle and kame deposits of the Norfolk Downs area north of Tobey Pond. It's unclear whether the rock in the photo is bedrock or a very large deposit (bedrock likely of marble).

A kettle pond forms during glacial retreat when a chunk of ice is buried under sediment, often in a delta (which occurred in the south end of Glacial Lake Norfolk). When the buried ice finally melts, a depression is left. If the local water table is high enough, a pond forms. Or if the local water table is marginal a wetland, like Tobey Bog, forms. To the north of Tobey Pond, additional kettles occur, but the water table is too low for these to be ponds (or bogs). Instead, they are simply pine-filled depressions in the old Norfolk Downs gold course. Pine prospers on well-drained and excessively drained soils. The abandoned Norfolk Downs golf course (today covered in ~50-year old white pine) in particular contains glacial deposition.

A few areas of bedrock appear, and these should be Stockbridge Marble showing through the Norfolk Window, but this was not confirmed on the ground. The sediments are deep; a test well near the town beech was drilled 113 feet, almost entirely through sand, without reaching bedrock. If all the sand were removed, the site would contain an interesting topography of chasms over 100 feet deep.



**Tobey Bog near Tobey Pond.** The bog is a depression among the glacial lake Norfolk delta deposit. It is a kettle, like Tobey Pond, formed from a buried chunk of ice that later melted. Today it holds black spruce, perhaps the southern-most stand in New England.

Warren (1969) suggests Glacial Lake Norfolk ended in a sudden burst and draining when the ice dam collapsed. Such events can be catastrophic and landscape shaping.

### **Importance**

This is the best, and really the only, extensive glacial deposition site in and/or adjacent to GMF. The site needs additional mapping, research and interpretation to sort out its remarkable story. That it is topped off with Tobey Bog and the North 40 Old Growth makes the area all the more interesting. An entire day could be spent here looking at glacial features, the bog, old growth, and the human land use legacy that formed as a result of the site's remarkable glacial history. Arguably, Norfolk history is directly tied to its ancestral glacial lake.

### **Research Questions**

Where are the ice margin deposits? Build a detailed map of the site's bedrock, kames, kettles, and moraines.

How has substrate type shaped succession on the Norfolk Downs golf course?

How has Glacial Lake Norfolk driven the history of the Norfolk Village?

### **Resources**

*Stone, Janet, et al. 2005. Quaternary geologic map of Connecticut and Long Island Sound basin. United States Geological Survey and Connecticut Department of Environmental Protection, Geological and Natural History Survey. <http://pubs.usgs.gov/sim/2005/2784/>*

*Warren, Charles. 1969. Glacial Lake Norfolk and drainage changes near Norfolk, Connecticut. In: United States Geological Survey (USGS) 1969 Chapter D: Geological Survey Professional Paper 650-D.*

## PHYSICAL LANDSCAPE 3: SLIDE AREAS ON BROWN BROOK

### Summary

The site contains two mass-wasting slides along Brown Brook. Geological processes continue today.

### Access

Best access is to hike down from Meekertown Road following Brown Brook.

### Specific Location

41°55'43.91"N; 73°16'8.84"W

### Comparative or Nearby Sites

Just upstream is the Mansfield Sawmill.

A number of collier hearths occur in the area.

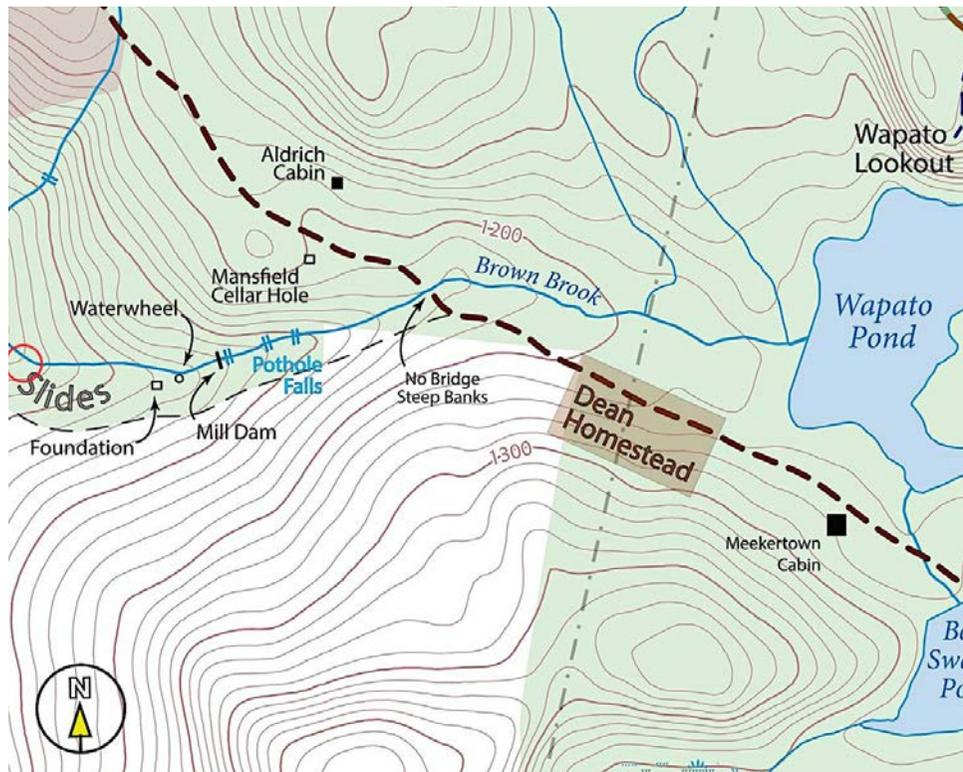

Location of slide areas on Brown Brook. Slides are located on south side of the stream at the bend.



One of the slide areas in the lower portion of Brown Brook. Such geomorphic sites are rare in GMF and forested New England in general.

### Description

This site contains two mass wasting (land slides) events. Their size was not measured, but is estimated at 20 meters in vertical height and 10 meters wide each. Together, they might total half an acre of open sand and gravel slope. It's unclear when these occurred, but likely it was during a large rain event. Quite possibly it was Tropical Storm Irene in 2012. Dating the site should be possible either in the field or by remote sensing.

### Importance

Because geological processes occur over vast spans of time, they are difficult to observe. But here we see geomorphology in action. No other wasting site is known in GMF.

### Research Questions

Slope stability?

Successional processes on an eroding slope?

Sediment origin (glacial deposit, fluvial deposit, or something else?)

## PHYSICAL LANDSCAPE 4: TALUS AND GLACIAL LAKE HOLLENBECK

### Summary

The sites display a large-block talus slope at the margin of Glacial Lake Hollenbeck.

### Access

Access is via Under Mountain Road 0.7 miles south of Canaan Mountain Road.

### Specific Location

*Talus slope:* 41°56'33.69"N; 73°16'52.74"W

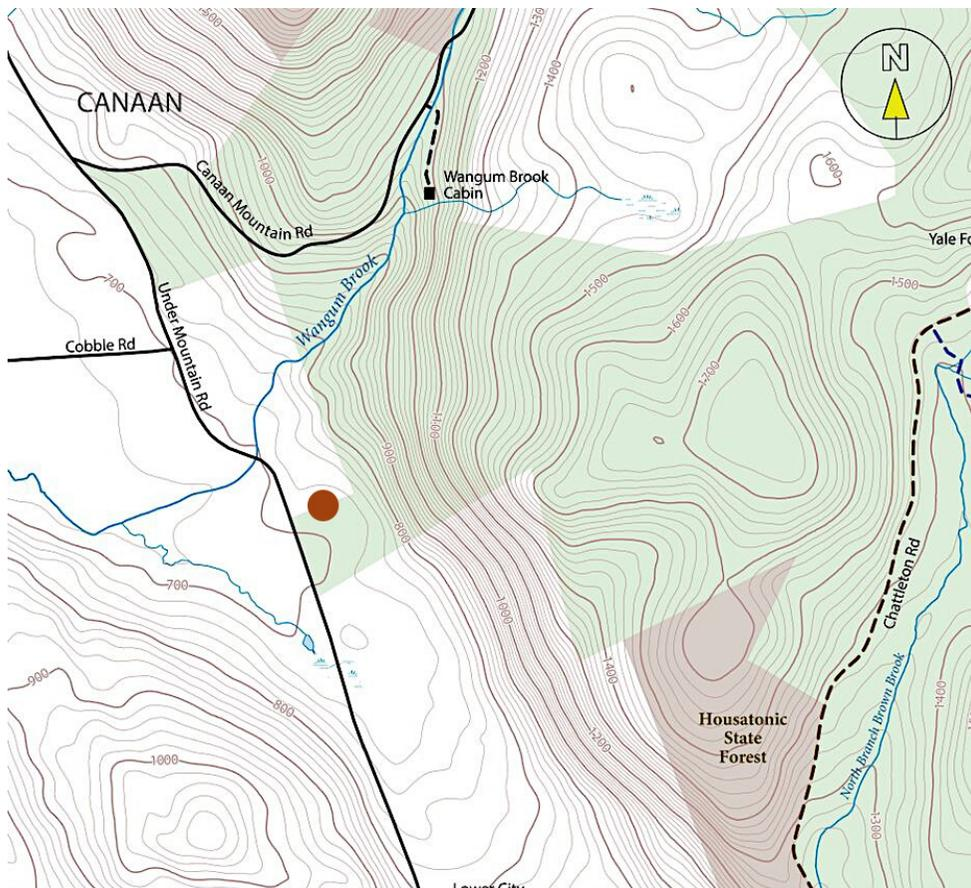

Location for Glacial Lake Hollenbeck and the Talus slope. Chestnut Orchard is marked for parking and access to talus.

### Comparative or nearby sites

A second talus slope occurs at the Appalachian Forest site described in the Natural Communities section. That area contains at least one large chunk of Stockbridge Marble. It's a larger, steeper slope than the one here. This is also the site of the Rich Talus Slope described in the Natural Communities section. An example of geology driving communities and human land use.

The Chestnut plantation occurs at this site.

Glacial Lake Norfolk is described in this section.

### Description

This site contains two somewhat unrelated features. First is the talus slope containing blocks of both Canaan Mountain Schist and Stockbridge Marble. The sizes of the boulders are impressive. Bedrock continues up the slope.

The second feature is Glacial Lake Hollenbeck. There is little to observe here beyond the valley and the fine sediments of the valley soil (in stark contrast to the talus slope). But a map (right) and imagination can make the glacial history of this west side of GMF more impressive. Glacial Lake Hollenbeck was an ice-dammed glacial lake on the north flowing Hollenbeck River and up Wangum Brook. Glacial Lake Great Falls, a sediment dammed lake, occurred later (when the ice dam of Hollenbeck melted) and today forms Robbins Swamp. See map.

### Importance

Large block talus slopes are common in Great Mountain Forest. Most of these occur on the plateau and on steep, often south-facing slopes (see Roche Moutenee entry). Glacial Lakes are rare; there is little to observe here beyond the imagination.

### Resources

Stone, Janet, et al. 2005. *Quaternary geologic map of Connecticut and Long Island Sound basin. United States Geological Survey and Connecticut Department of Environmental Protection, Geological and Natural History Survey.* <http://pubs.usgs.gov/sim/2005/2784/ConnSheet2.pdf>

EXPLANATION	
<b>Ice-dammed Glacial Lakes</b>	
ln	Glacial Lake Norfolk
low	Glacial Lake Cornwall
lho	Glacial Lake Hollenbeck
ld	Glacial Lake Danbury
lpt	Glacial Lake Pootatuck
lw	Glacial Lake Winsted
lnp	Glacial Lake Nepaug
lbr	Glacial Lake Bristol
log	Glacial Lake Coginchaug
lma	Glacial Lake Manchester
lsb	Glacial Lake Salmon Brook
lrb	Glacial Lake Roaring Brook
lc	Glacial Lake Colchester
lex	Glacial Lake Essex
lon	Glacial Lake Oneco
lvo	Glacial Lake Voluntown
lp	Glacial Lake Pachaug
<b>Sediment-dammed Glacial Lakes</b>	
	Glacial Lake Connecticut
	Glacial Lake Middletown
	Glacial Lake Hitchcock
lg	Glacial Lake Great Falls
ll	Glacial Lake Lime Rock

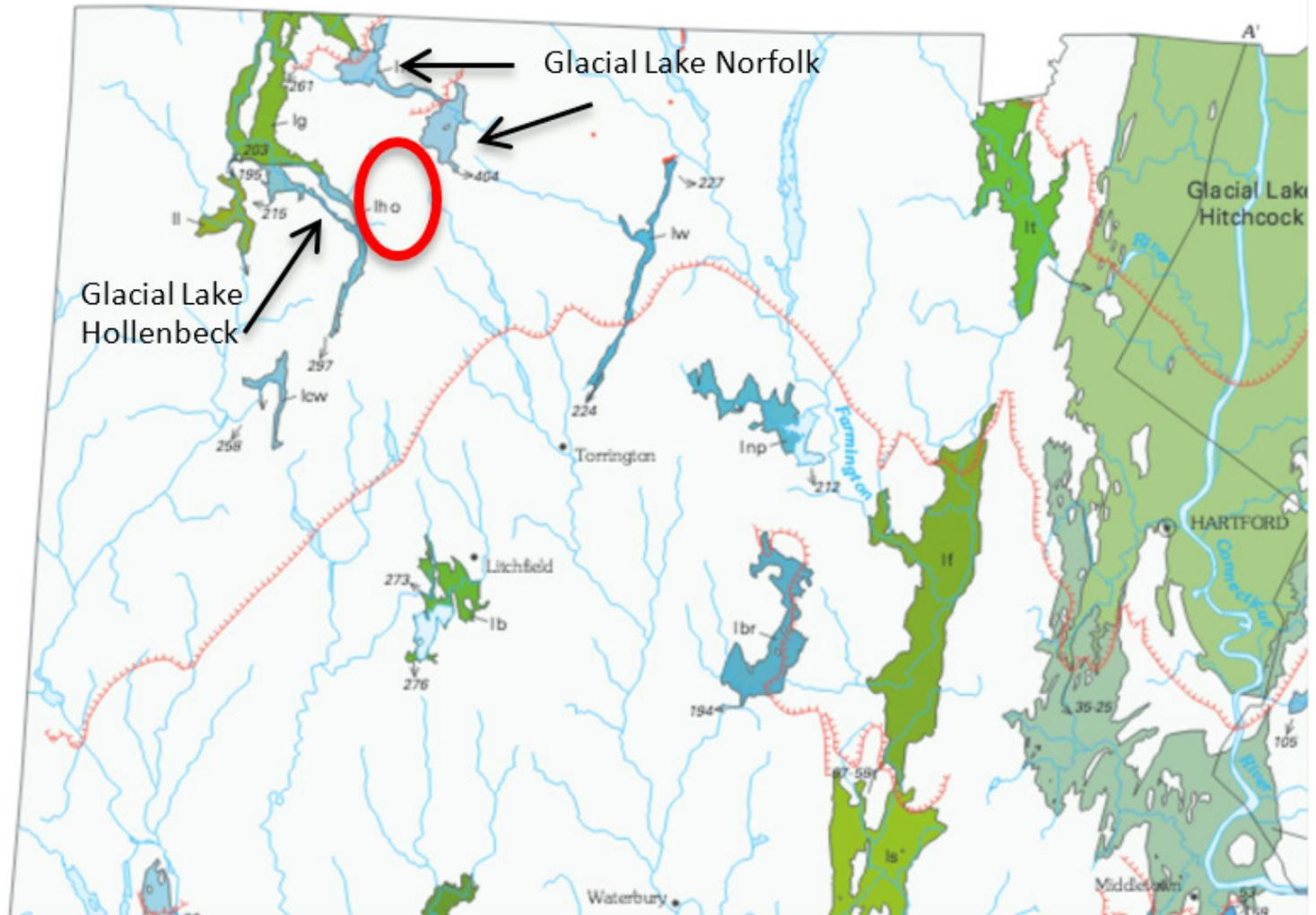

Map of glacial lakes in Connecticut by Stone et al. (2005) here cropped to show only NW Conn. Great Mountain Forest approximately shown with red circle. Ice margin (dam) in red shown for Lake Norfolk.

## Photographs

See Rich Talus Slope section in Natural Communities and Chestnut Plantation.

## PHYSICAL LANDSCAPE 5: ROCHE MOUTONÉE

### Summary

A Roche Moutonnée is a glacial erosional feature common in New England. Great Mountain Forest contains several. Here four sites are shown in close proximity in the southern reach of GMF.

### Road Access

Wapato Overlook on the Number Four Trail. Meekertown Road near the Number Four Trail (see map right). Crissey Pond Overlook (not shown or described here).

### Specific Location

*Wapato Overlook Parking*: 41°56'0.25"N; 73°15'11.52"W

See map right for additional locations.

### Comparative or Nearby Sites

See Rocky Outcrop Communities in Natural Communities section.

### Description

A roche moutonnée is a glacial erosional feature created by thick glacial ice moving over a hilly or mountainous landscape. In this case, the south-flowing ice shaped gentle slopes on the north side of hills. Once the ice reached the peak, the change to downward pressure plucked large blocks of rock from the south side. This creates a cliff.

Once the cliff formed, the downward pressure of the ice driving into base level carved a depression where a small lake (called a tarn) develops. In GMF, these lakes had in-filled to become wetlands by historical times, but for a few millennia after the ice melted 15,500 years ago, they would have been small lakes. The wetlands were dammed in historic times and their surface level increased to create new lakes.

Vegetation on the south-facing slopes was not explored extensively or systematically. On the crest, communities of white oak and other dry sited plants occur. Community composition and structure should be examined for potential patterns.

### Importance:

Roche Moutonnées are very common in New England. In GMF the summits and south-facing cliffs create drier, sub xeric communities.

### Research Questions

What community types occur on steep south-facing glacially plucked cliffs?  
What has been the vegetation development of the wetlands/lakes at the bases of the cliffs? (A palynological study)

### Photographs

See photographs in the next site for Crissey Pond roche moutennee overlook.

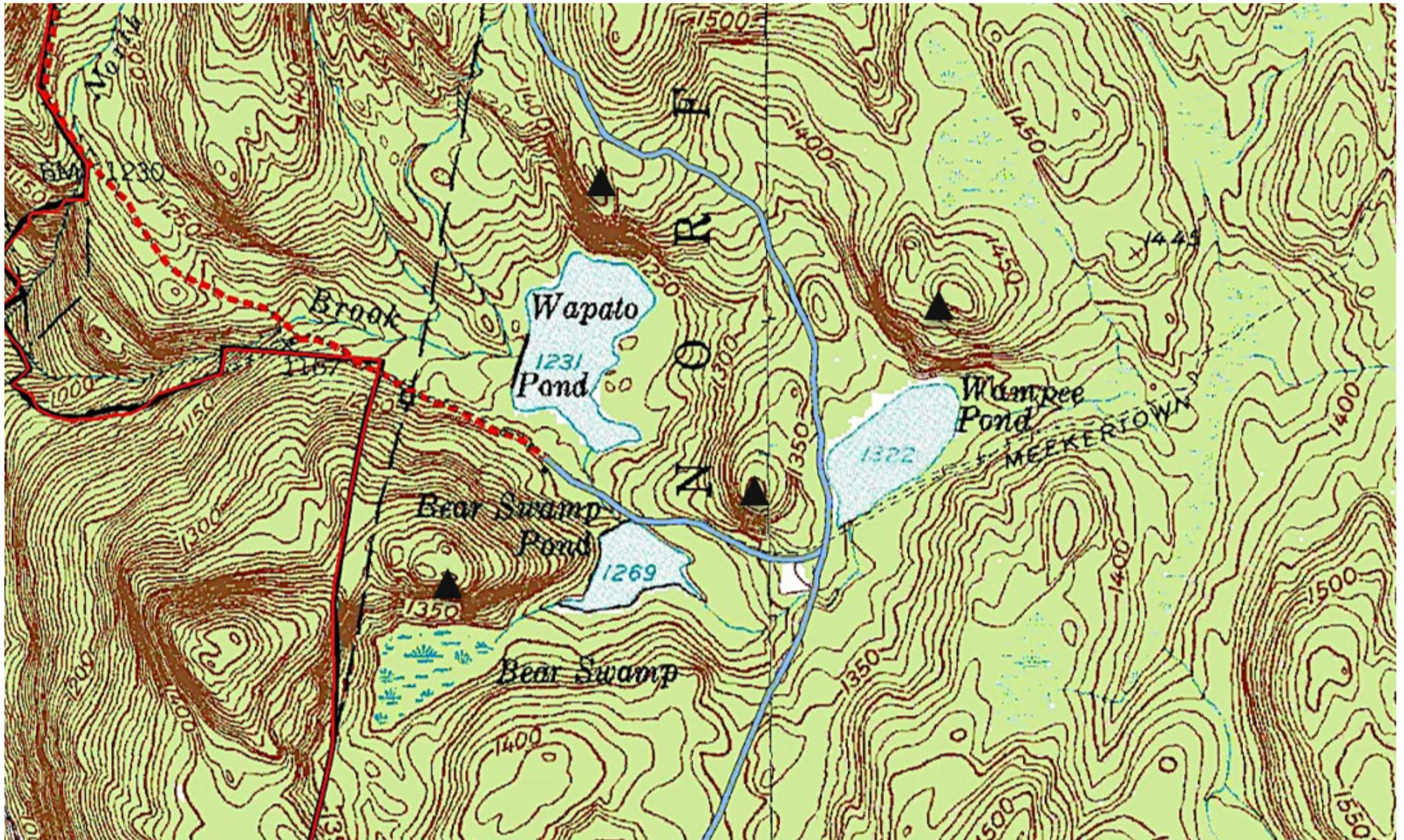

Four Roche Moutonnées (black triangles) in southern Great Mountain Forest shown here on a USGS topographic map to highlight the steep south-facing slopes. As the ice flowed southward, it shaped gentle slopes on the north side of hills. The south sides were plucked of stones as the ice rode over top. The cliff on the north side of Crissey Pond (not shown) is also a Roche Moutonnée.

## PHYSICAL LANDSCAPE 6: NATURAL LAKES

### Summary

Many lakes at Great Mountain Forest are human-created, typically by building small dams in formerly swamp or open wetland environments. Some lakes, however, are long-lived natural lakes of glacial origin.

### Road Access

See GMF maps for access to ponds.

### Specific Location

See maps for locations.

### Comparative or nearby sites

None listed.

### Description

Determining what lakes have always occurred on Great Mountain Forest and which are human created is not necessarily an easy task. The



Crissey Pond at Great Mountain Forest from the Crissey Pond overlook. Crissey is one of several natural ponds.

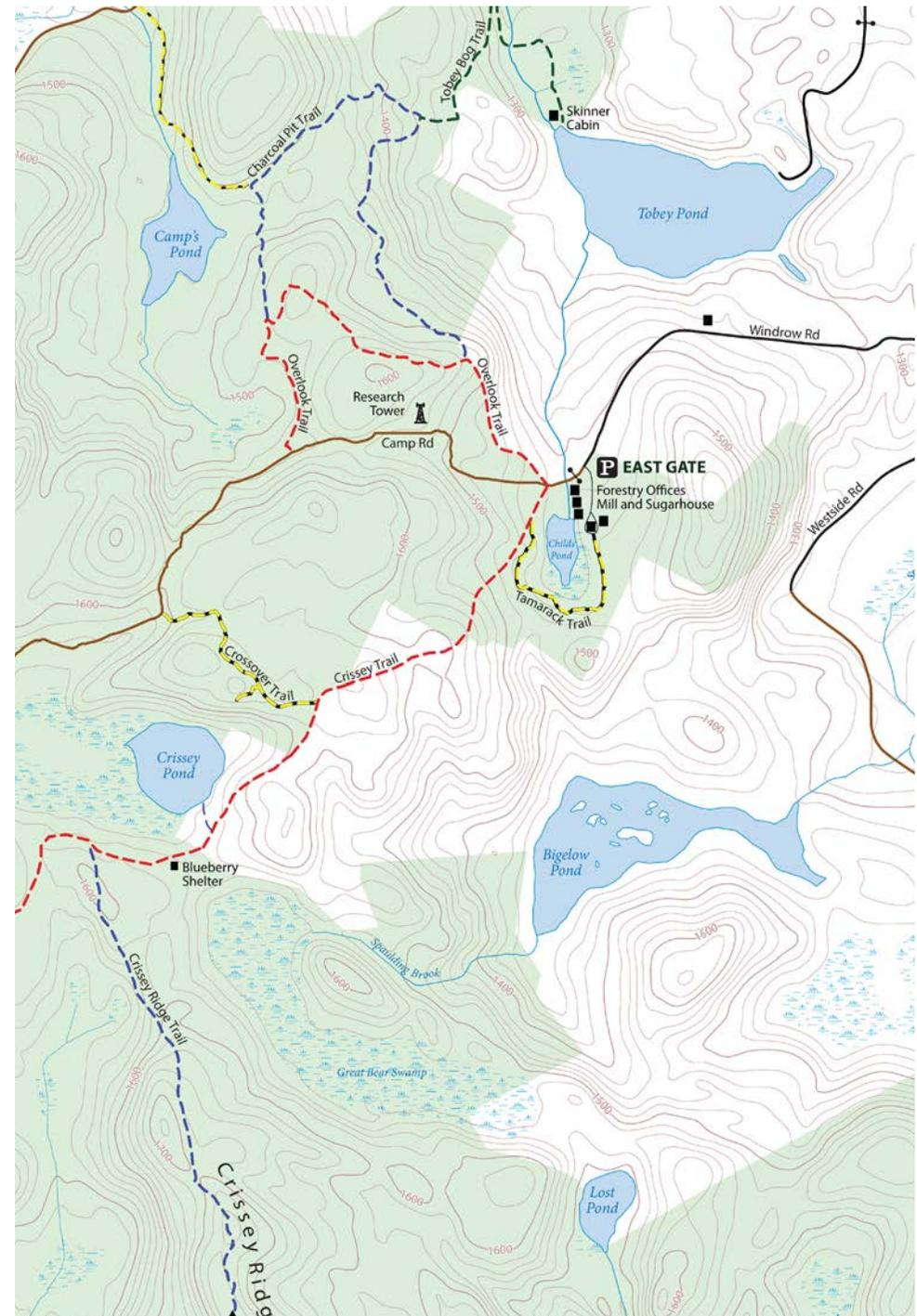

Locations of likely natural lakes in GMF. Compare to Fagan's 1853 map.



Fagan's 1853 map of Norfolk shows five GMF ponds: Tobey, Camp, Mud (Crissey), Balcom (Lost), and Bigelow (smaller, unnamed).

presence or absence of a dam hardly provides the full story. For this site description we used Weiner's thesis and the 1853 map (Fagan) to try to uncover which lakes and ponds are natural and which are human created.

It's nonetheless worth noting that even the human ponds such as Wampee and Wapato began as natural lakes after the ice melted 15,500 years ago. It's only been through infilling over the millennia that lakes have progressed to wetlands.

Weiner (1955, p.14) notes:

The ponds and lakes include six that are naturally of their present size; these are Tobey, Camps, Crissey, Seldom Seen, and Dolphin Ponds and

Wangum Lake. McMullen and Bigelow Ponds are natural bodies of water whose extent has been enlarged by damming. Childs, Wampee, Bear Swamp, and Wapato Ponds are wholly artificial in origin, occupying the sites of former swamps.

The map by L. Fagan (1853) shows the following ponds with their 1853 names and contemporary name in parenthesis: Tobey, Unnamed (Camps), Mud (Crissey), Balcom (Lost, aka Dolphin), Wangum Lake, Unnamed (Bigelow, smaller than present), Unnamed (Tannery).

On the 1853 (Fagan) map, only Tobey is showed with a dam. And we know from the glacial history (see previous site) that Tobey is a natural kettle lake. Tannery is showed with a sawmill, so its origin is questionable (and it is off GMF lands).

Each pond might have a slightly different mechanism for formation. For example, while Tobey is a kettle lake (see Glacial Lake Norfolk), Crissey is a tarn crated at the base of a roche moutennee (see roche moutennee). As noted previously, other roche moutennee's had wetlands below them that are now are dammed. Other ponds may be kettles, but the surficial geology maps don't suggest that.

### Importance

Natural ponds have value for research. They are also good for the human imagination.

### Research Questions

Look through historical documents to uncover when dams were constructed.

Pollen research could determine the postglacial vegetation history at GMF.

### Resources

Wiener, H. 1955. *History of Great Mountain Forest. Dissertation, Yale University.*

Fagan, L. 1853. *Map of the Town of Norfolk. Retrieved through Library of Congress: <http://www.loc.gov/item/2011589304>*

Fagan, L. 1853. *Map of the Town of Canaan. Retrieved through the Library of Congress: <http://www.loc.gov/item/2004626473/>*

## PHYSICAL LANDSCAPE 7: IRON TRAIL AND STONEMAN SUMMIT

### Summary

The Iron Trail's legacy traces back to the days of the iron industry, where it served as a highway linking colliers and forges. Today it is still active as one of the most beautiful hikes at GMF, replete with the legacies of geologic and human activity. It is also a great site to see rocky outcrop lichen and moss communities at their most vibrant (see Natural Communities 4)

### Access

Visitors may park at the Childs Center, then walk 5 minutes up Canaan Mountain Road to the head of the trail. By the Spring of 2016, there should be a parking area at the trailhead, which now has a kiosk.

### Location

*Iron Trail Trailhead:*

41°58'16.20" N; 73°16'19.22" W

*Quarry:*

41°57'53.68" N; 73°16'42.26" W



View of Wangum Lake from the Stone Man Summit.

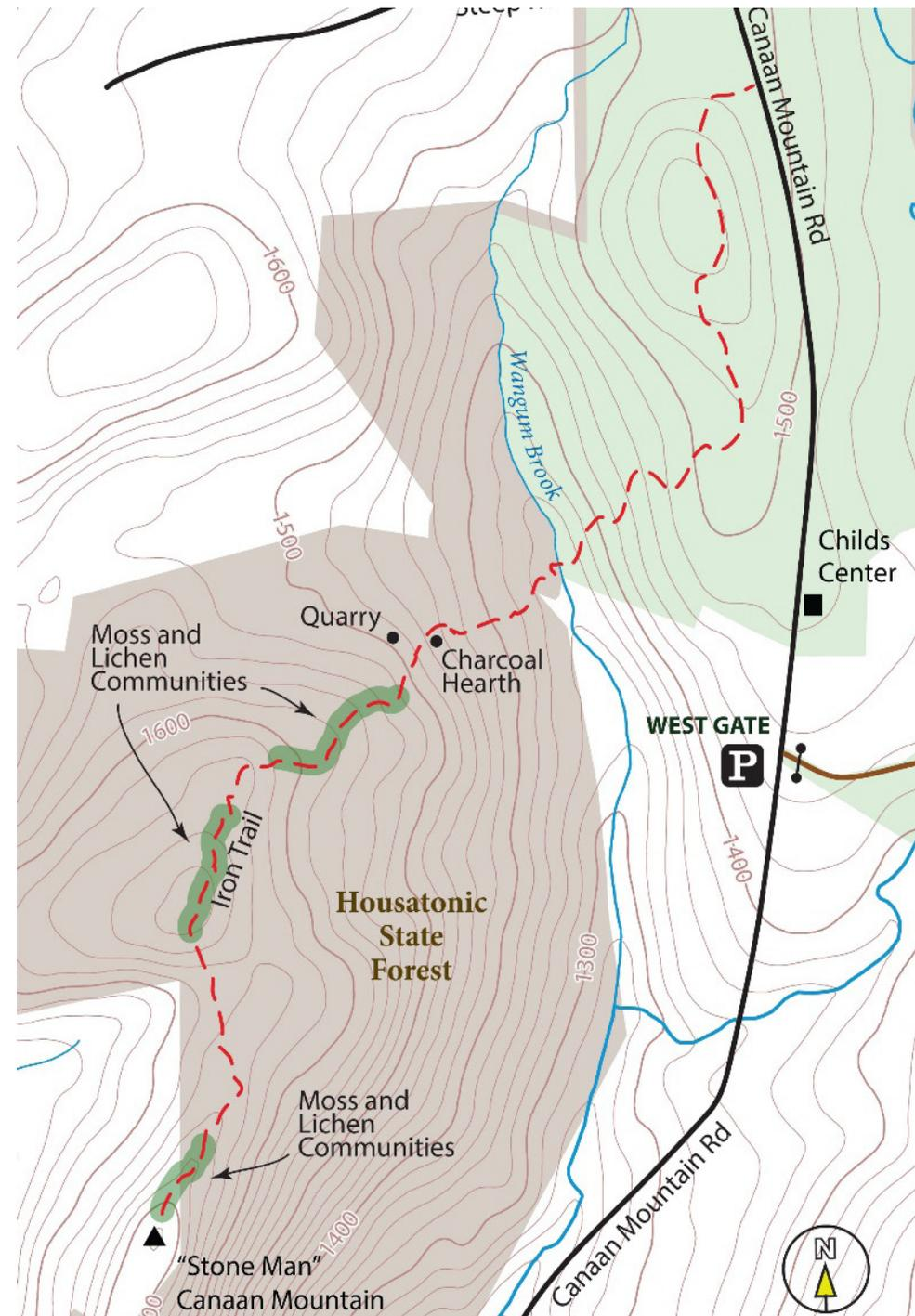

Iron Trail Trailhead: 41°58'16.20" N; 73°16'19.22" W

Quarry: 41°57'53.68" N; 73°16'42.26" W

### Nearby or Comparable Sites

The trailhead is across the street from the Mergen Pinetum (Research Sites 4), the Pitch Pine Study plantation (Research Sites 5) and the New England Cottontail Habitat (Forest Management 10).

### Description

The Iron Trail that leads the way up Canaan Mountain to the Stoneman Summit was once the major thoroughfare for transporting charcoal produced in the forest to the Beckley blast furnace in North Canaan. Colliers made the ascent in both directions with their carts, up until the last gasps of the furnace in 1919. The surrounding hemlock-dominated forest entered the charcoaling cycle at a very early date, and shows much evidence of this legacy. There is a distinct charcoal hearth on the left side of the trail, just before the path becomes considerably steeper. The abundance of multi-trunked hardwoods surrounding it suggest an intensive rotation of coppice cutting.

Farther up the trail, there is an old granite quarry, evidenced by smooth downward cuts in the stone face next to the trail. Such rocks did not have a direct purpose in the iron working process, but were likely rather used for sturdy house foundations in the surrounding towns and villages.



View of the Conklin limestone quarry in North Canaan.



Edge of the granite quarry on the Iron Trail. Stone workers once chiseled slabs from the ground for use in masonry projects.



The Stone Man: past and present.



The Great Mountain Forest summer crew.

The path weaves up through dense hemlock forest and emerges onto an open bald ecosystem (see Natural Communities 4: Balds and Rocky Outcrops). For the most part, only occasional small stunted trees (mostly pines) provide any semblance of canopy cover. Two small areas serve as exceptions: flat areas abutting ascending rock ledges where old communities of oak and hemlock form thick shady mixtures once more. We were unsure how to explain this phenomena. It could be that soil collected more deeply in these pockets due to some quirk of the winds or the ancient glacier's path. Alternatively, it could be that the topographic arrangement somehow offers the sites some protection against the spread of fire, which was a frequent occurrence in the days of collier activity. Safe in their fire refugia, trees can grow taller and advance to a later climactic stage than the surrounding environment.

The current day Iron Trail terminates at an artful pile of rocks known as the "Stone Man". From the summit, one can see Wangum Lake to the northeast, surrounded by the Housatonic State Forest that lies adjacent to GMF. From the right vantage point, one can also see the Mountain House on Canaan Mountain Road (more easily once the leaves have fallen). Looking southwest, the old North Canaan limestone quarry is

clearly visible in the distance. As with so many features at GMF, the chance occurrence of the underlying geology had great influence on the shaping of the landscape. As described in the Human History section, limestone is a key component in the iron forging process, and its abundance in the region enabled the industry to flourish—prompting the land clearing and fires that influence the canopy communities in GMF to this day.

### Resources

Carlson, Hans 2015. *A walk up Stoneman*. *Norfolk Now* online:  
<http://www.nornow.org/2015/07/01/its-only-natural-a-walk-up-stoneman/>

## PHYSICAL LANDSCAPE 8: BISHOP'S CAVE

### Summary

The site of an old bishop's nature getaway, among giant slabs of fractured metamorphic rock. A great place for the geologically minded to study recently exposed formations.

### Access

The cave is most easily accessed by charting a course eastward into the open hemlock forest from the Number 4 Trail. After passing the northernmost point of the Blackberry Hill toe slope, head southward, hugging the ridgeline on your right until you arrive at the cave (see map).

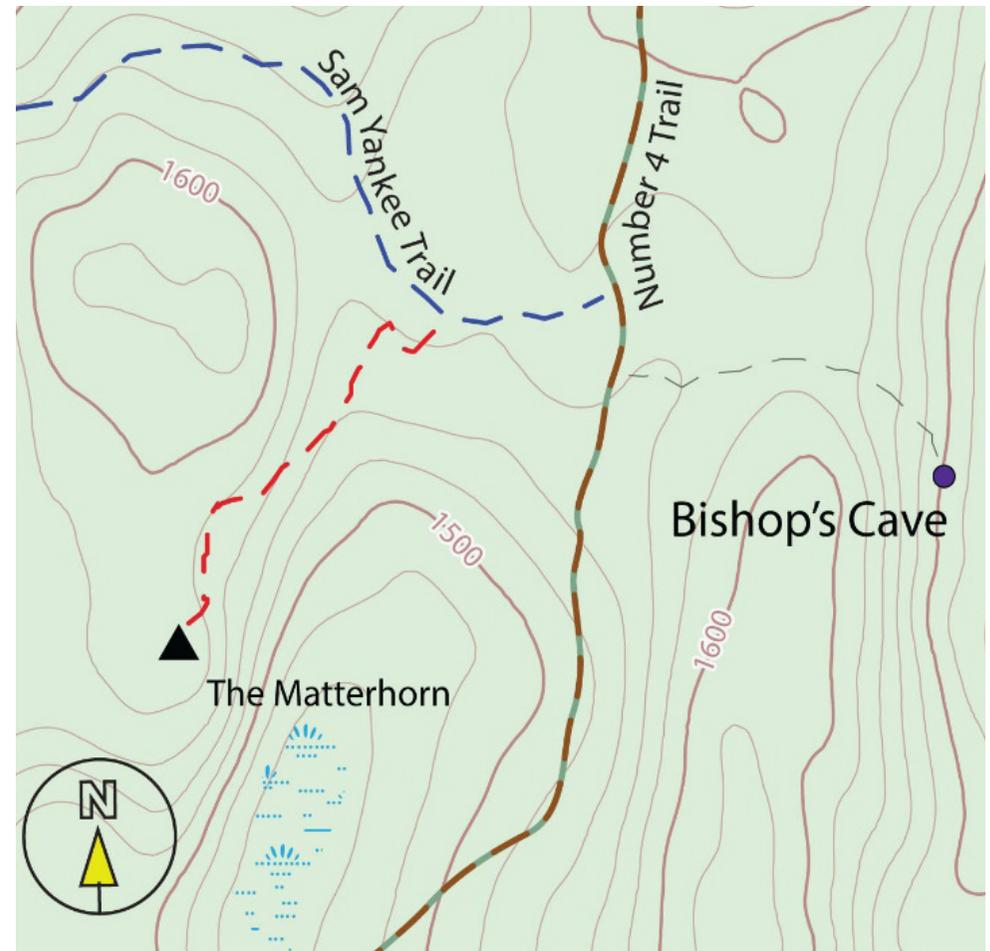

Map of Bishop's Cave in Great Mountain Forest.



The exterior of Bishop's Cave. The surrounding area is filled with giant rock slabs like these, broken off of the main cliff face.



This is the top of Bishop's Cave. The ferns growing so prolifically here are rock polyploidy (*Polypodium virginianum*), a species that grows well atop dry exposed rock. They can be found in many similar environments throughout the forest.



Inside Bishop's Cave. The stacks of firewood are actually American chestnut (*Castanea dentata*), collected before the blight destroyed all the adult trees in the region a century ago. Chestnut wood is so rot resistant that the logs are preserved to the present day with little sign of decomposition.

### Location

*Starting point from Number 4 Trail:* 41°56'40.30" N; 73°15'5.19" W

*Bishop's Cave:* 41°56'37.56" N; 73°14'53.85" W

### Nearby or Comparative Sites

There is a magnificent bald community at the top of Blackberry Hill, just to the south (Natural Communities 3). The trailhead for the Sam Yankee Trail is nearby to the west (Land Use History 11).

### Description

This site is named in commemoration of Rev. Robert M. Natch of Springfield, Massachusetts, who dwelt for a time at the Aldridge cabin. Folklore states that the cave was his meditation spot for communion with nature, with bird feeders set up hanging from the jagged rock face to draw creatures close. To this day there are still piles of firewood stacked up inside, and some curious metal sheeting of unknown provenance. The cave itself is not really a cave in the strict sense of the term. The eastern face of the Blackberry Hill toe slope features a sheer cliff of metamorphic rock where



**Exposed Quartzite.**

large slabs have broken off—one of which happened to land in such a way as to create a modest shelter space. Wandering up and down among the crags of cloven rock, one can find the mineral layers of the metamorphosed rock deposits. These were exposed by the splits in the rock face, and haven't yet had time to erode smoothly away like most of the underlying geology of the Great Mountain Forest. The Bishop's Cave area is thus a fascinating place to study the different types of metamorphic rock of the Forest region. The nooks and crevices of this landscape also provide ideal habitat for many species of mammalian wildlife. Bobcats in particular often make their dens such places. Eroded soil from farther up the hill has begun to fill in many of the cracks, where many trees and shrubs have found places to flourish. Though not novel ecologically, it is nonetheless a beautiful place to scramble around and explore among the sparkling crystalline geologic features.

### **Research Questions**

Survey of the different exposed rock formations.

Survey of wildlife that live in this area.

What is the plant community composition on rock faces and within soil accumulated crags?



**Exposed Quartzite.**

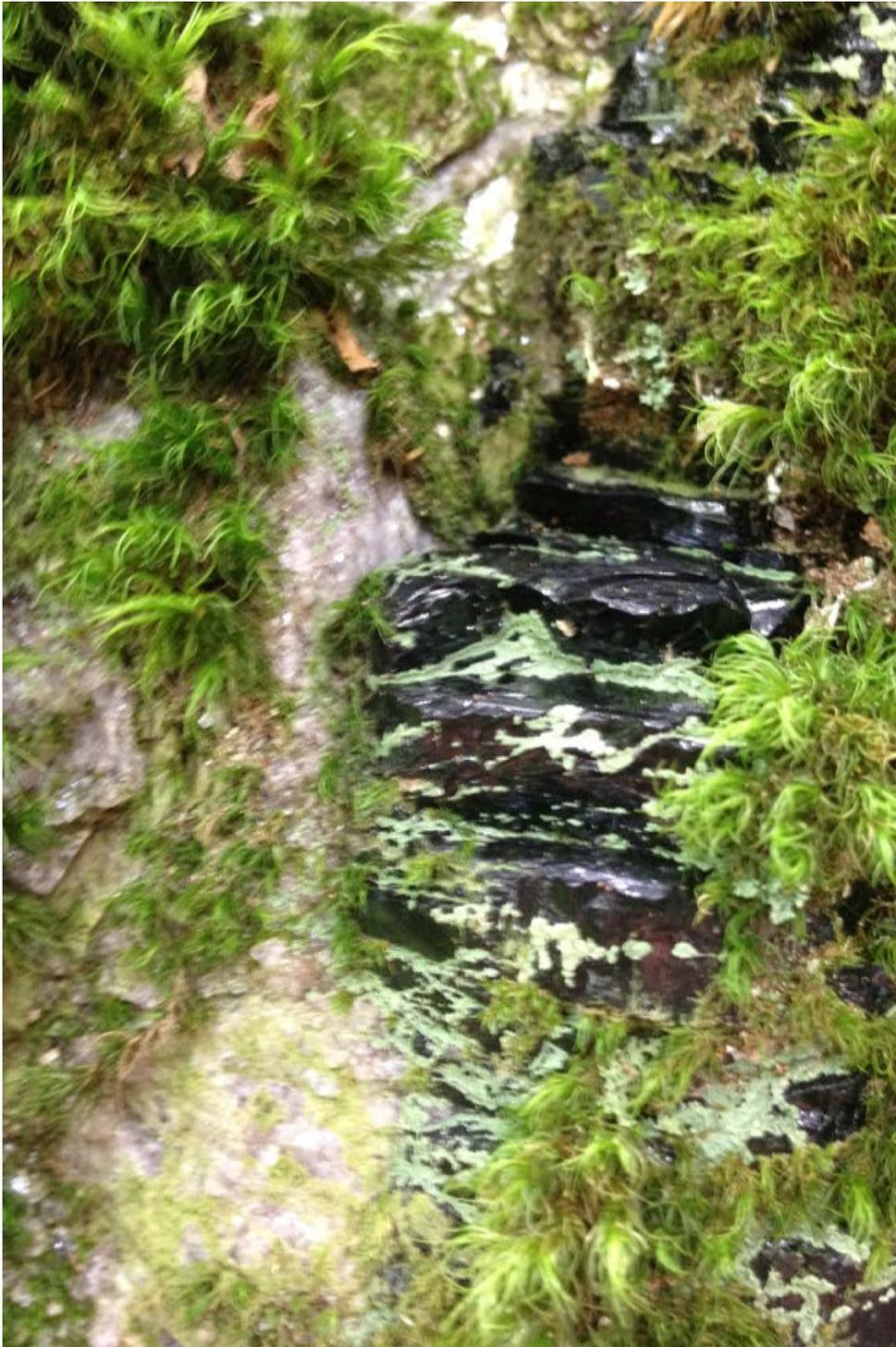

Exposed schist deposit. The original layers of deposition are still clearly visible.







## SITES OF INTEREST: UNIQUE NATURAL COMMUNITIES

One approach to landscape ecology is to ask two simple questions: What here is unique? And what here is typical? In New England as a whole, alpine communities are rare and unique, as are beach dunes. And hemlock-hardwood forests are typical. In other regions, such as in the southern United States, this forest type would be unique.

Great Mountain Forest contains a number of unique natural communities as well as many unusual human-created communities (e.g. katsura-dawn redwood-tulip poplar forest, for example). While those human-created sites are interesting, and many of those are described in the *Cultural Landscape* or *Forest Management* sections, here we describe nine communities that are unique or atypical in Great Mountain Forest, or New England more generally.

The dominant natural cover type is equally important as the unusual ones. For this section we call that the *Matrix Forest*. This is the dominant forest cover type on GMF. The matrix forest of GMF contains a variety of species found in varying proportions depending on the site's topographic setting, specific substrate, and disturbance history. The following table lists species typically found in the matrix forest, albeit in mixed proportions with occasionally absent species.

The Matrix Forest dominates mid-topographic positions at GMF. In the lowest elevations, one encounters swamps (hemlock and/or red spruce dominated; see Spruce Swamps in this section) or other open wetlands. At higher elevations, forests become drier and oak-dominated with sporadic balds (see the Oak Communities and Bald Communities in this section). The Matrix Forest, therefore, is a mesic, widespread communities type occurring largely in between these two extremes.

SPECIES	COMMON NAME	NOTES
<i>Tsuga canadensis</i>	Eastern Hemlock	declining; rarely absent
<i>Fagus grandifolia</i>	American Beech	occasional
<i>Betula alleghaniensis</i>	Yellow Birch	occasional
<i>Prunus serotina</i>	Black Cherry	common, often large size
<i>Quercus rubra</i>	Red Oak	occasionally absent
<i>Betula lenta</i>	Black Birch	common
<i>Acer saccharum</i>	Sugar Maple	occasionally absent
<i>Acer rubrum</i>	Red Maple	common
<i>Kalmia latifolia</i>	Mountain laurel	occasionally absent
<i>Hamamelis virginiana</i>	Witch Hazel	common
<i>Panax trifolius</i>	Dwarf Ginseng	relatively common in season
<i>Osmunda claytoniana</i>	Interrupted fern	common
<i>Dennstaedtia punctilobula</i>	Hay scented fern	patchy

By definition, the Matrix Forest can be found almost any where in GMF. We find it in places that were not heavily agricultural (cleared), not too dry (upper slopes) or too wet (bottomlands) or too rich (lowest elevations where specific geology changes). What follows in this section are the gems in between: the sites that are too dry, too wet, too rich, or too old to be a part of the matrix forest.

Human disturbance has been a significant driver of community composition in Great Mountain Forest for centuries or millennia. It is useful to consider natural disturbance, as well as the two other forces driving community composition and structure on landscapes: topography and substrate. Together, the three of them can account for all the variability found in a forest ecosystem (Wessels 1997).

Topography drives vegetation distribution through aspect and slope. Southern aspects have warm, dry sited species, while north-facing aspects typically contain mesic, cool sited species. Substrate variability comes from soils moisture, nutrients, bedrock characteristics, etc. Disturbance can be natural and include wind throw (the most common disturbance in New England), hurricanes, fire, etc. Human caused disturbance can include fire, land cover changes to agriculture (or other), and logging from single tree selection to clear cutting. On the following page is an idealized cross section of Great Mountain Forest community types.

## NATURAL COMMUNITIES 1: RICH TALUS SLOPE

### Summary

The site contains one of the richest forest herbaceous flora sites in Great Mountain Forest. Identified as a Rich Talus Slope community by Mickelson (2000), the site contains excellent to outstanding spring ephemeral diversity scattered among large blocks of calcium rich and acidic rocks. Spring ephemerals flower typically from late April to mid-May.

### Access

Access is from Under Mountain Road, 0.7 miles south of Canaan Mt Road. Park in the grass at the Chestnut Orchard on Under Mountain Road. Parking coordinates: 41°56'30.90" N; 73°17'02.00" W

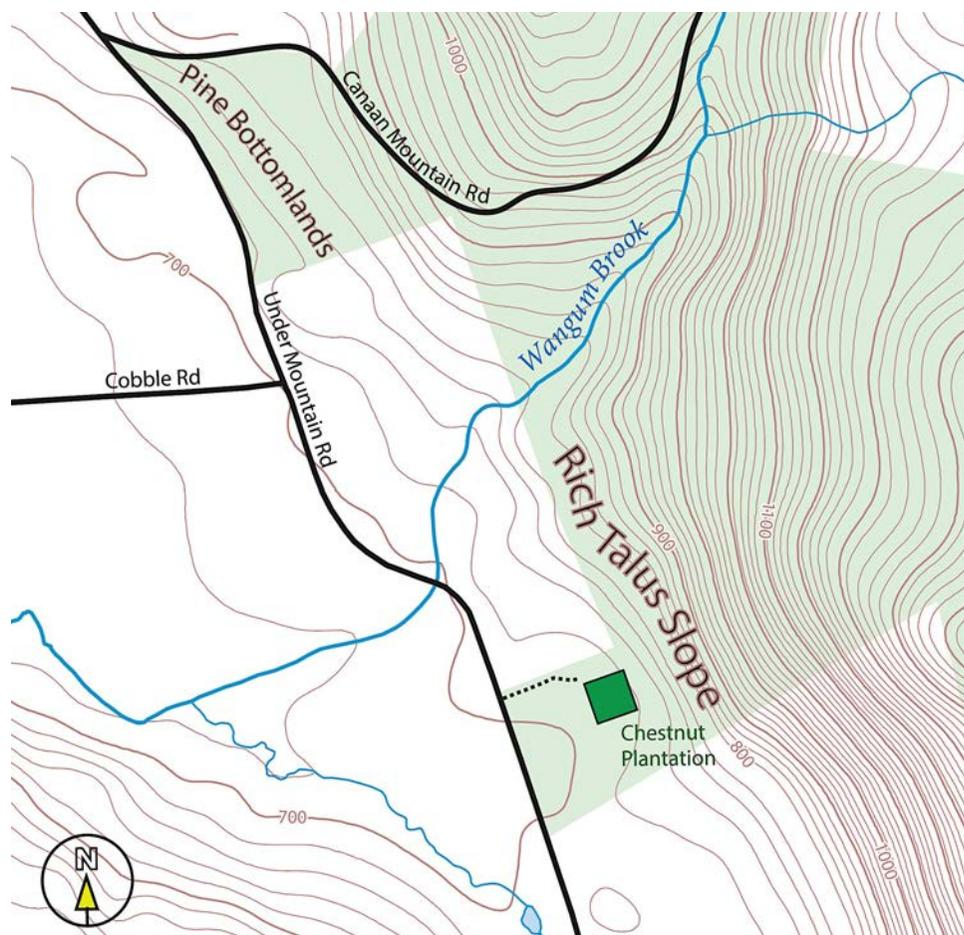

Map of the location of the Rich Talus Slope

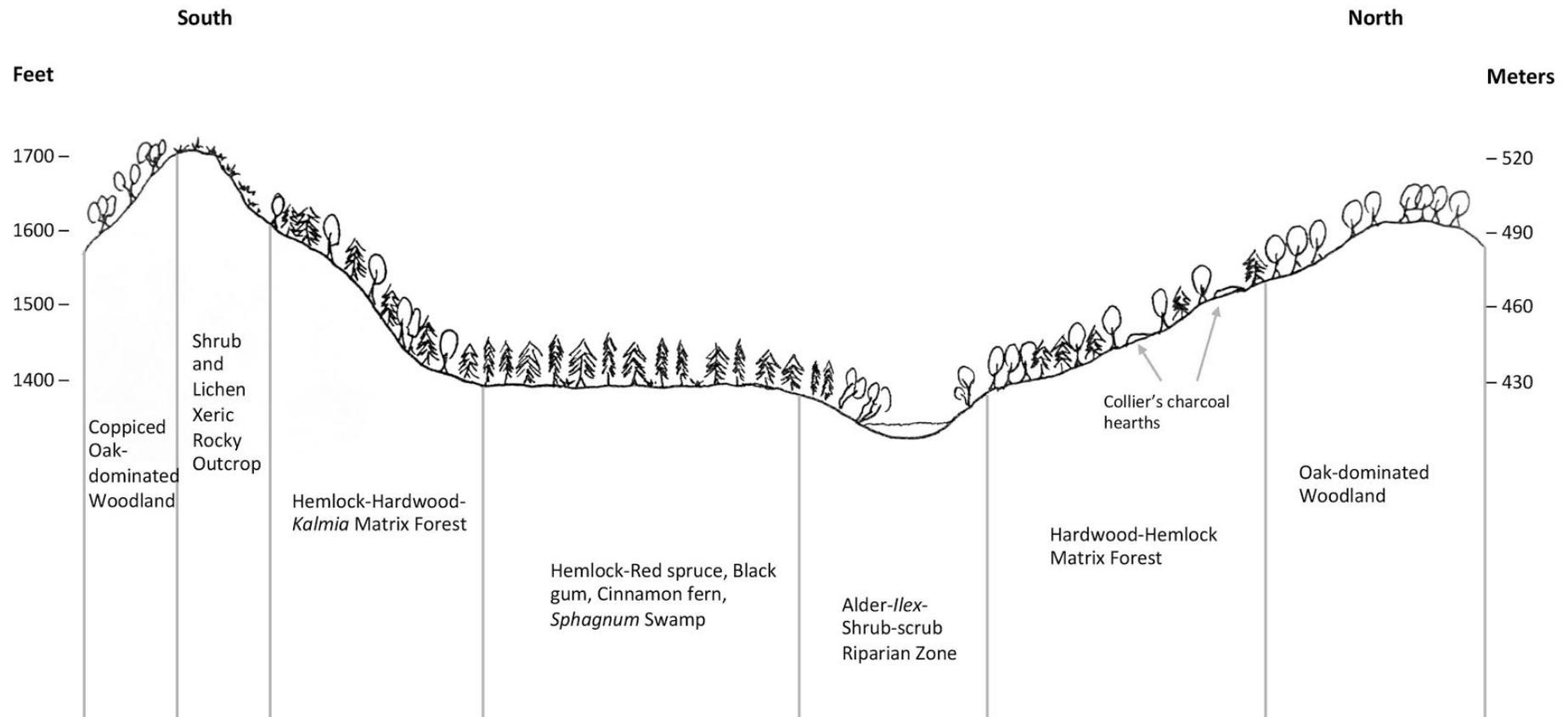

Idealized Vegetation Cross-section from Great Mountain Forest. This simplified illustration of GMF vegetation shows patterns of community arrangement with regard to topographic position, aspect, hydrology, and to some degree, disturbance. The oak-dominated woodlands (far left and right) occur on ridges in sub-xeric environments with extensive previous disturbance. They are described in this section. The rare rocky outcrop communities, also described in this section, occur on summits and cliff areas lacking extensive soil development such as Stoneman, Blackberry Hill, and Collier's Cliff. The hemlock-hardwood matrix forest is described briefly in this section. It comprises the dominant community type in GMF. South facing slopes often have more oak and less hemlock. The hemlock-spruce swamp occurs at some higher elevation bottomland areas with high water table. It is described in this section as Red Spruce Swamps.

### Specific Location

From Under Mountain Road parking, walk 100 meters to the Chestnut Orchard, and another 100 meters into forest. Coordinates: 41°56'33.50"N; 73°16'53.50"W

### Comparative or Nearby Sites

Chestnut Orchard is adjacent. Appalachian Forest is an extension of this community but is richer in tree diversity.

Bartholomew's Cobble, located in Canaan, CT and adjacent Mass, is a site with quartzite and marble and has the highest fern diversity in North America.

### Description

This site contains one of the best floristic areas in GMF. Calciphilic vegetation (trees and herbs) occurs among large blocky rocks fallen from the steep slope above. The trees and herbs indicate rich soil and are atypical elsewhere in GMF. Controlled largely by geological differences, this site is

exceptional and unlike others in GMF. Land use history contributes to the site's richness, having not been cleared for agriculture or cleared by timber cutting. The terrain is steep and rugged with large blocks of local rock (mainly acidic schist). To a certain degree, this prevented intensive land use.

Local geology, as it pertains to the diverse flora at the Rich Talus Slope, is described below. This section also provides interpretation of the land use history based on observable features as well as a list of herbaceous plants found on the site.

## Geology

The site's geology contributes to its richness. Unlike the majority of GMF, which occurs on hard, acidic, Canaan Mt. Schist, this site lies on the edge of the calcium-rich base member of the Middle Ordovician-aged Walloomsac Schist. This unit is described by the USGS as: Dark-gray to white, massive to layered schistose or phyllitic calcite-phlogopite marble. Black to dark-or silvery-gray, rarely layered schist or phyllite, composed of quartz, albite, and commonly garnet and staurolite or sillimanite (locally strongly retrograded to chlorite and muscovite). Locally feldspathic or calcareous near the base.

These units lie close to Stockbridge Marble, the dominant rock type of the Housatonic Valley in NW CT. This calcium-rich rock occurs proximal to Walloomsac Schist and forms the quarry rock of Canaan, CT. It is described by USGS as: White, pink, cream, and light-gray, generally well bedded dolomitic marble interlayered with phyllite and schist and with siltstone, sandstone, or quartzite, commonly dolomitic.

Most of GMF is comprised of Canaan Mountain Schist, as described by USGS: Dark-gray to silvery, generally rusty weathering, medium- to coarse-grained, well-foliated, massive to well-layered schist and schistose gneiss, composed of quartz, plagioclase, biotite, muscovite, and generally garnet and sillimanite; also layers of amphibolite.

Because of the different geologic substrates in GMF, and this site in particular, we find different vegetative response. Whereas most of GMF contains plant communities of more acidic-loving nature, this site contains calciphiles and other plants indicative of rich sites.

## Soils

Deeper soils occur low on the slope (toe slope), near the valley bottom. Abundant populations of *Dicentra* sp. and wild leeks occur here. Among the rocks, pockets of soil facilitate growth. However, among the

rocks are shallow soil pockets, which permit plants such as columbine.

## Trees

Trees indicating a rich site include: sugar maple; bitternut hickory; white ash; basswood; shagbark hickory; tulip poplar; big tooth aspen; and hop-hornbeam. Trees typically measure up to 20-inches in diameter. A few coppiced trees indicate prior land-use. Higher up the slope, where soils become thinner and the influence of nutrient-rich rocks becomes less pronounced, trees change to red oak, black birch, some white oak, and hemlock becomes dominant. Still higher, chestnut oak occurs with low-bush blueberry on thin-soiled balds and outcrops. It is a remarkable transition in such a short area, driven largely by substrate differences.

## Land Use History

Two features indicate land use history on this site. Wire fences run uphill on the southern property line. This indicates grazing, though it is unclear which side of the fence the grazing occurred on (or both sides). Barbs indicate cattle (not sheep). Second, a few coppiced trees (bitternut hickory and red oak) show cutting has occurred in the past. The difficulty of the terrain, however, would have made this a challenging and infrequent activity. Malformed old growth (>250 years) black birch and white oak higher up the slope, beyond the area of outstanding flora, show the landscape was not completely cleared. Steep slopes often were not intensively exploited throughout the eastern forest and frequently contain outstanding remnants of native vegetation, including old growth trees and rich herbaceous flora. Evidence of fire, in the form of basal scars, occurred on the upper slopes. No charcoal hearths were found.

A list of herbaceous and woody vegetation (no trees) from the site is below. The list is not exhaustive. In general, a lot of these species rarely occur elsewhere in GMF, or occur in very low densities. Here, however, they are generally abundant.

## Importance

This site contains rich herbaceous flora not commonly found elsewhere in GMF. The rich soil, a result of calcium-rich geology, hydrology, and the complex topography and access that prevented high levels of human disturbance, creates conditions for the site's rich flora. The site is fairly isolated from other similar sites. In eastern Forests, the ratio of tree species to herbaceous species is about 1:5 (Gillium, 2007).

SPECIES	COMMON NAME	NOTES
<i>Trillium erectum</i>	Wake-robin; red trillium	Common
<i>Viola</i> sp.	Blue Violet	
<i>Aquilegia canadensis</i> *	Wild Columbine	Uncommon; on <i>Ca</i> rocks
<i>Sambucus canadensis</i>	Elderberry	Common among rocks
<i>Sanguinaria canadensis</i>	Blood Root	
<i>Gallium</i> sp.	Bedstraw	Occasional; near edge
<i>Actaea pachypoda</i>	Doll's eyes	
<i>Dicentra cucullaria</i> *	Dutchman's breeches	Abundant
<i>Ribes cynosbati</i>	Prickly gooseberry	On rocks and cliffs
<i>Polygonatum biflorum</i>	Solomon's-seal	
<i>Asarum canadense</i>	Wild ginger	Unusually dense patches
<i>Allium tricoccum</i> *	Wild leeks	Abundant; lower slope
<i>Caulophyllum thalictroides</i>	Blue cohosh	Could be Early Blue Cohosh
<i>Cardamine maxima</i>	Large Toothwort	Listed Rare; confirm
<i>Hamamelis virginiana</i>	Witch-hazel	
<i>Mitella nuda</i>	Miterwort	
<i>Erythronium americanum</i>	American Trout-lily	
<i>Rubus</i> sp.	Raspberry sp.	
<i>Anemone americana</i>	Blunt-lobed hepatica	
<i>Ranunculus abortivus</i>	Small flower crowfoot	
<i>Maianthemum racemosum</i>	Solomon's plume	
<i>Viburnum acerifolium</i>	Maple leaf viburnum	
<i>Arisaema triphyllum</i>	Jack-in-the-pulpit	
<i>Uvularia</i> sp.	Bellwort	
<i>Maianthemum canadense</i>	Canada mayflower; May lily	
<i>Parthenocissus quinquefolia</i>	Virginia creeper	Uncommon; edges
<i>Vitis</i> sp.	Wild grape sp.	Edge
<i>Boechera laevigata</i>	Smooth rock cress	Rocky sites; higher up
<i>Trientalis borealis</i>	Starflower	
<i>Aralia nudicaulis</i>	Wild sarsaparilla	
<i>Claytonia virginica</i>	Spring beauty	
<i>Alliaria petiolata</i>	Garlic mustard	Exotic; lower slope; edge
<i>Carex hitchcockiana</i>	Hitchcock's Sedge	Noted by Mickelson (2000)

\* Indicated by McLachlan and Bazely (2001) as species particularly sensitive to forest disturbance.

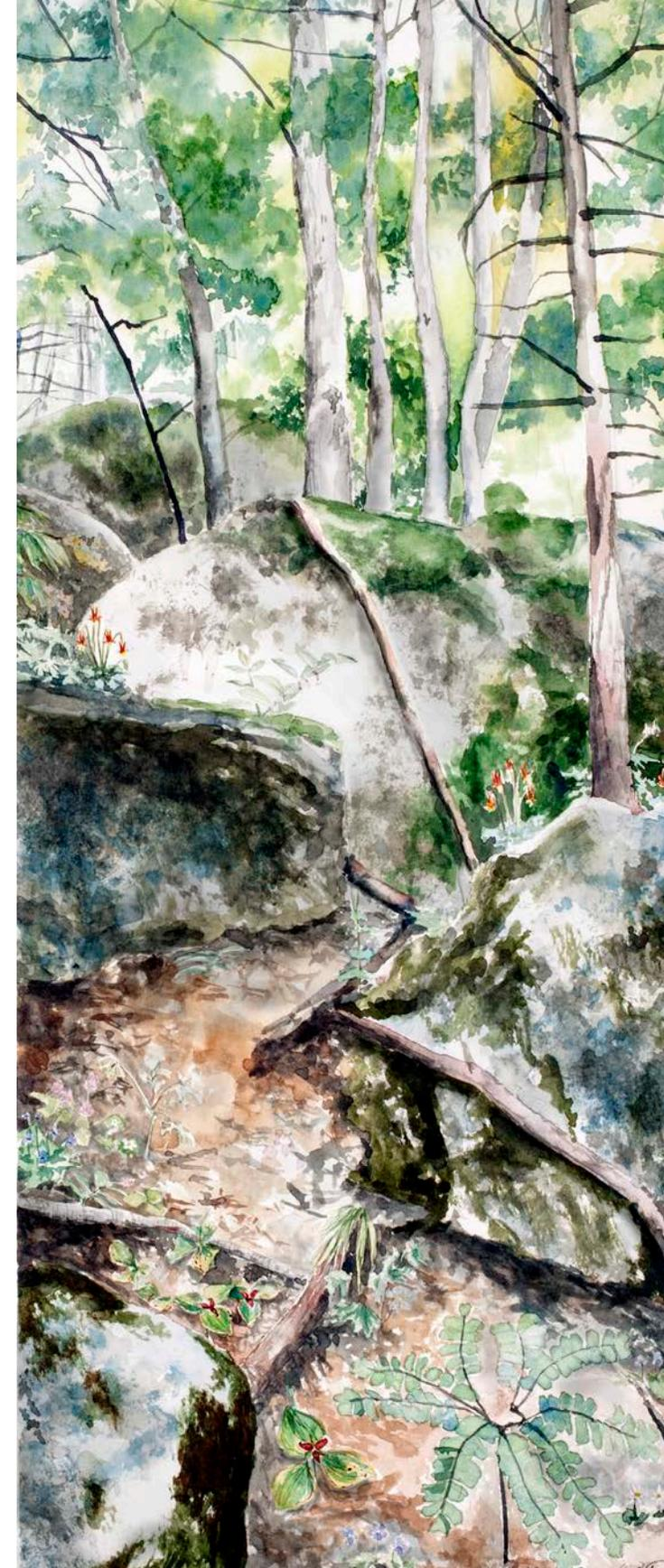



A host of spring ephemeral wildflowers at the Rich Talus Slope. This Photo shows: Wake robin; Dutchman's breeches; Solomon's seal; round-leaved hepatica; Thalictrum; as well as sedges and Christmas fern.

The robust population of Wild leeks could be subject to exploitation. GoBotany of the New England Wildflower Society states: "a study concluded that a 10% harvest once every ten years is the maximum sustainable harvest." Please avoid the temptation to harvest wild leeks at a site of this significance.

The herbaceous flora is a fascinating and beautiful group of often-overlooked significance. Their presence signifies the rich, innumerable number of relationships present in the eastern deciduous forest.

### Research Questions

- How will this site be affected by ash decline from the emerald ash borer?
- How is garlic mustard competing with native herbaceous flora?
- Do soil conditions differ in various topographic positions among the rocks?
- How does this affect plant distribution?



Base of the slope at the Rich Talus Slope showing an exceptionally large patch of Wild Leeks, with sugar maple, among talus. The base of the slope is very rich with its deep soil. It is also close to the edge, indicated here by early successional wild grape (*Vitis* sp.)



Mid-level on the Rich Talus Slope. Sugar maple seen here. Benches and pockets of soil form among the course rocks, which forms much structure and topography for wildlife. The difficult terrain prevented historic intensive exploitation.

## Resources

### Field Identification

Newcomb, L. 1977. *Newcomb's wildflower guide*. Little, Brown, and Company.

Horn, D. et al., 2005. *Wildflowers of Tennessee, the Ohio Valley and the Southern Appalachians*. Lone Pine Publishers.

### Review Articles

Gilliam, F. 2007. *The Ecological significance of the herbaceous layer in temperate forest ecosystems*. *BioScience*. 57(10): 845-858.

Whigham, D. 2004. *Ecology of Woodland Herbs in Temperate Deciduous Forests*. *Annual Review of Ecology, Evolution, and Systematics*. 35: 583-621.

## Other Articles

Singleton, R., et al. 2001. *Forest herb colonization of post-agricultural forests in central New York State, USA*. *Journal of Ecology*. 89: 325-338.

Motzkin, G., et al. 1999. *Vegetation patterns in heterogeneous landscapes: The importance of history and environment*. *Journal of Vegetation Science* 10: 903-920.

McLachlan, S. and D. Bazely. 2001. *Recovery patterns of understory herbs and their use as indicators of deciduous forest regeneration*. *Conservation Biology*. 15(1): 98-110.

Flinn, K. and M. Vellend. 2005. *Recovery of forest plant communities in post-agricultural landscapes*. *Frontiers in Ecology and Environment*. 3(5): 243-250.

Hermý, M. and K. Verheyen. 2007. *Legacies of the past in the present-day forest: a review of past land-use effects on forest plant species composition and diversity*. *Ecological Restoration*. 22: 361-371.

## NATURAL COMMUNITIES 2: RED SPRUCE SWAMP

### Summary

This entry describes the red spruce swamp, identified at several isolated locations in GMF. This is a southern reach for red spruce in New England found here in high-elevation acidic basins with poor drainage.

### Access

Road access for all sites is via GMF internal roads and permission is required for vehicles. See specific locations below. Great Bear and Crissey Swamps are easiest to access.

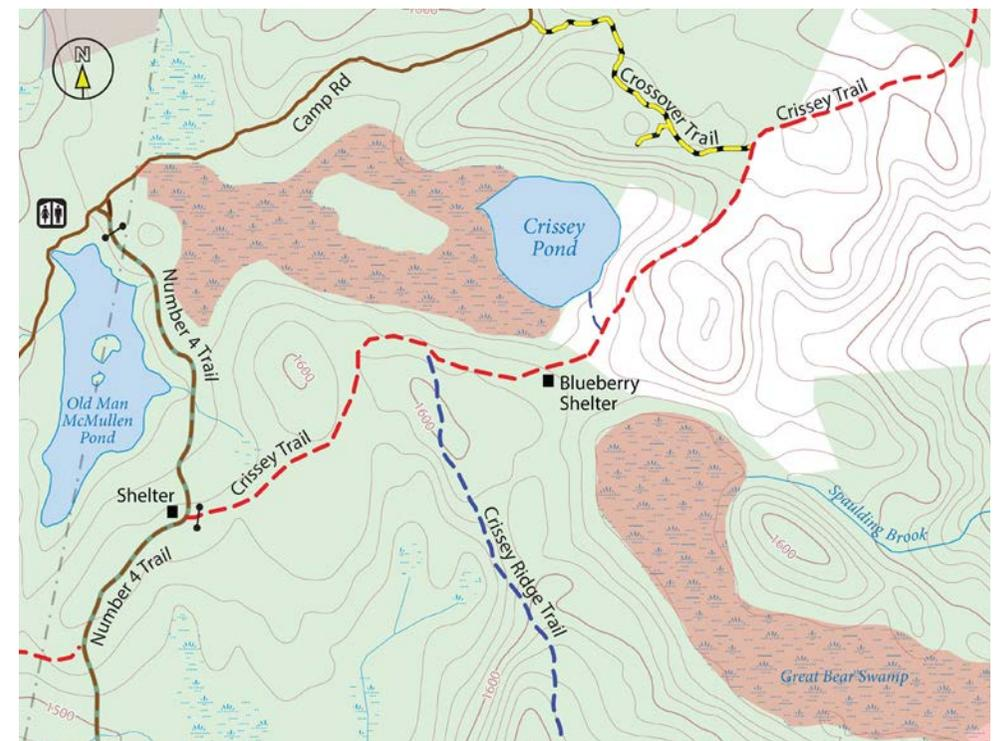

Locations of red spruce swamps in Great Mountain Forest colored red. The northern swamps of Crissey and Great Bear have easiest access. Bear Swamp in south lacks spruce. The site described here is the unnamed swamp southeast of Wampee Pond.

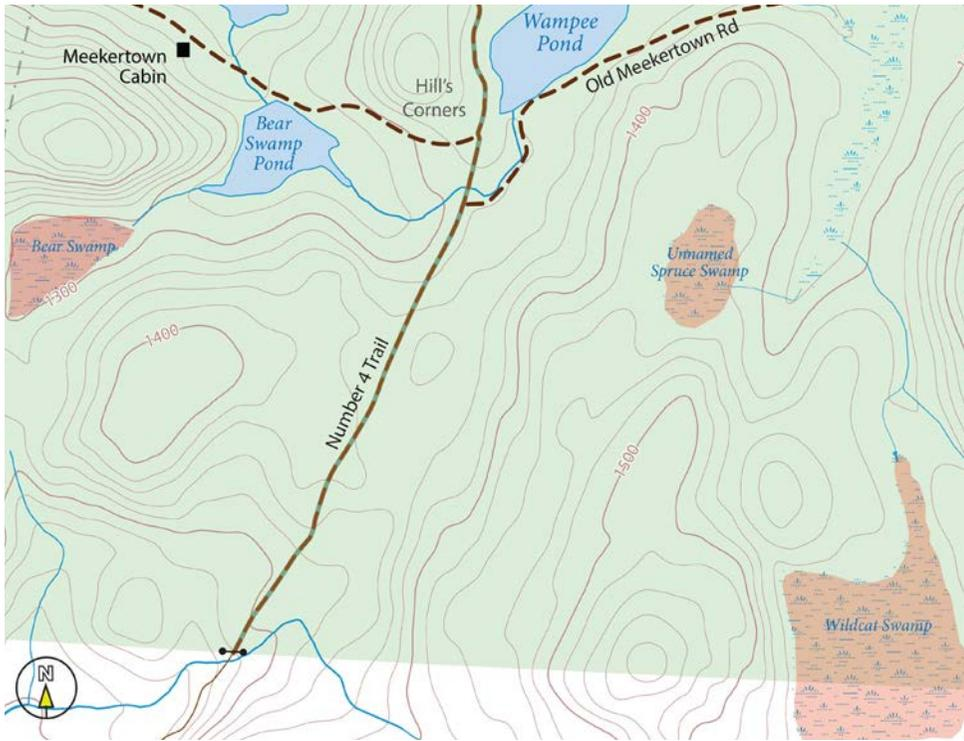

standing water and *Sphagnum* further acidifies the substrate.

On the following page is a list of species identified during our brief recognizance. The list is not complete. Several sedges and many mosses were unknown to us. Additional botanical work could be done in these communities.

It should be clear to any hiker or explorer of the Northeast’s mountain landscapes that this list resembles community types or individual species typically found much farther north and at higher elevations. *Clintonia*, *Coptis*, *Sphagnum*, and red spruce, as well as the moose that frequent this site, all indicate a cold, northerly environment. Perhaps the site’s topographic setting high on a ridge (cold) and also in a basin (colder) facilitates this. Nonetheless, the fact that Mountain laurel occurs here suggests temperatures do not reach those of the boreal communities in which most species here are found; laurel does not survive below -20°F (-30°C). Perhaps then, it is the site’s cool, moist and acidic nature that creates the quasi-boreal composition.

### Specific Location

Unnamed Spruce Swamp southeast of Wampee Pond: 41°55’23.67”N; 73°14’33.55”W

Wildcat Swamp: 41°54’56.52” N; 73°14’16.13” W

Great Bear Swamp: 41°57’15.93”N; 73°14’8.35”W

### Description

This is a community type found in GMF at several locations, however, this entry describes specifically the small, unnamed swamp south of Wampee Pond. Although the site is termed “red spruce swamp” a more accurate descriptor for the community would be an eastern hemlock – red spruce – sphagnum swamp. Even this, however, fails to capture the nuance and beauty of these exceptional communities.

The site is located on a ridge at 1430 feet (436 m). On the ridge, however, it’s situated in a shallow, poorly drained basin. The water table is at or near the surface and the ground is covered with *Sphagnum* spp. and other mosses, small patches of open water, and low hummocks containing trees and shrubs. Bedrock is acidic, old, Canaan Mountain Schist. The

SPECIES	COMMON NAME	NOTES
<i>Tsuga canadensis</i>	Eastern Hemlock	Dominant
<i>Acer rubens</i>	Red Maple	Occasional
<i>Betula alleghaniensis</i>	Yellow Birch	Occasional
<i>Picea rubens</i>	Red Spruce	Occasional; up to 15” dbh
<i>Nyssa sylvatica</i>	Black Gum	Uncommon; old growth
<i>Pinus strobus</i>	White Pine	Edges
<i>Quercus rubrus</i>	Red Oak	Seedlings
<i>Nemopanthus mucronatus</i>	Mountain Holly	Common
<i>Ilex verticillata</i>	Winterberry Holly	Occasional
<i>Vaccinium corymbosum</i>	Highbush blueberry	Common
<i>Kalmia latifolia</i>	Mountain laurel	Common
<i>Osmunda cinnamomea</i>	Cinnamon fern	Abundant
<i>Thelypteris simulata</i>	Bog fern	Common
<i>Calla palustris</i>	Wild calla; water arum	Wet pools
<i>Coptis trifolia</i>	Goldthread	Common
<i>Clintonia borealis</i>	Blue-bead lily	Uncommon
<i>Sphagnum</i> spp.	Sphagnum spp.	Abundant
<i>Cornus canadensis</i>	Bunchberry	Common
<i>Gaultheria hispidula</i>	Creeping snowberry	Rare



Red Spruce *Picea rubens* overstory with *Sphagnum* spp. and graminoid ground cover. Water is near the surface and subtle variations in elevation create depressions with *Sphagnum* and hummocks with ferns and other herbaceous plants.



A more open area in the redspruce swamp with standing water and wild calla (*Calla palustris*). These pockets tend to form around the edges of the swamps.



An old-growth black gum (*Nyssa sylvatica*) tree stands in the Unnamed Red Spruce Swamp. Cinnamon ferns cover the ground, occasionally mixed with bog fern. The black gums in this swamp are ancient – perhaps 500 years old, or older.

Mickelson (2000) identified additional species in other Red Spruce Swamps at GMF that may also occur at this site. These include: Creeping snowberry (*Gaultheria hispidula*); Labrador tea (*Rhododendron groenlandicum*); Northern yellow-eyed grass (*Xyris montana*).

This swamp contained abundant sign of moose (scat and tracks). Also seen were catbird and northern junco.

It is worth noting that the old-growth black gum trees reach perhaps 500 years. A look into the canopy of these trees reveals broken tops and regrowth. This is a very typical situation for this species. Where it grows on a ridge (in a swamp) it is subject to strong winds and ice storms. The wood is brittle and the tops easily break off. But the tree persists. Several of these trees were hollow, also typical for the species when reaching ancient status.

### Importance

Several of these species reach their southern-most occurrence in New England here. Mickelson (2000) listed the Red Spruce swamps of GMF as moderately high diversity. Mickelson also noted several rare/threatened/endangered plants from these communities.

It is important to note this site is fragile and exploration should be limited to small groups at infrequent intervals.

## Comparative or Nearby Sites

GMF contains several Red Spruce communities. These are mapped in Mickelson (2000). There is a charcoal hearth and fireplace at the north end of this swamp in the uplands.

Interestingly, other similar swamps including Bear Swamp (south of Wampato Pond) and the swamp south of Crissey Ridge are nearly identical in composition and structure, except that they contain no red spruce.

## Research Questions

Why do some swamps contain red spruce and others do not?

A complete botanical inventory of all swamps.

How has hydrology of these red spruce swamps changed in recent decades?

And how will it change under future climate scenarios?

Do these swamps contain fossil pollen that would aid in uncovering paleoecology of GMF?

Is red spruce subject to the same atmospheric stressors occurring in high-elevation red spruce communities farther north?

## Resources

Mickelson, J. 2000. *Great Mountain Forest Conservation Evaluation: vegetation and natural community rapid assessment. The Nature Conservancy, Middletown CT.*

## NATURAL COMMUNITIES 3: OLD GROWTH

### Summary

At least five small stands of old-growth forest, primarily eastern hemlock, occur in GMF. This entry describes them as well as the general context of old growth in GMF. The definition of “old growth” is fraught with ambiguity, opinion, and debate, and these sites, to some purist, may not qualify as “old growth”. Nonetheless, a stand of hemlocks (and/or other species) reaching 300-400 years old qualifies as old growth or ancient forest under many definitions.

Scattered throughout GMF are also individual old growth trees, defined here as being trees over 250 years or near the maximum age for the species. Ancient hemlocks, red and white oaks, tulip poplar, black and yellow birch, black cherry, and black gum have been observed at GMF.

### Access

Lost (Dolphin) Pond: Access is via the Goodnow Trail to the property line at Lost Pond.

North 40: Access is via the gravel road near Tobey Pond and Tobey Bog.

Bigelow Pond: Best access via Crissey Trail and then off trail around Great Bear Swamp.

Wildcat Swamp: Access via Number 4 Trail.

Long Swamp: Access via Number 4 Trail.

### Location

*Lost (Dolphin) Pond:* 41°56'54.39"N; 73°13'31.90"W

*North 40:* 41°58'50.13"N; 73°13'32.60"W

*Bigelow Pond:* 41°57'30.48"N; 73°13'41.42"W

*Wildcat Swamp:* 41°55'2.06"N; 73°14'28.85"W

*Long Swamp:* 41°55'22.31"N; 73°14'21.77"W

### Description

The concept of “old growth” is an ambiguous one. See Hilbert and Wiensczyk (2007) for a review of definitions. However, within the context of GMF, and the intense levels of forest exploitation and management that has occurred for over 200 years, certain characteristics elevate a forest stand to “old growth.” These include structural characteristics (trees in all stages of development from seedlings to snags and downed logs), age (trees at the maximum ages for the species), and composition (species associated with

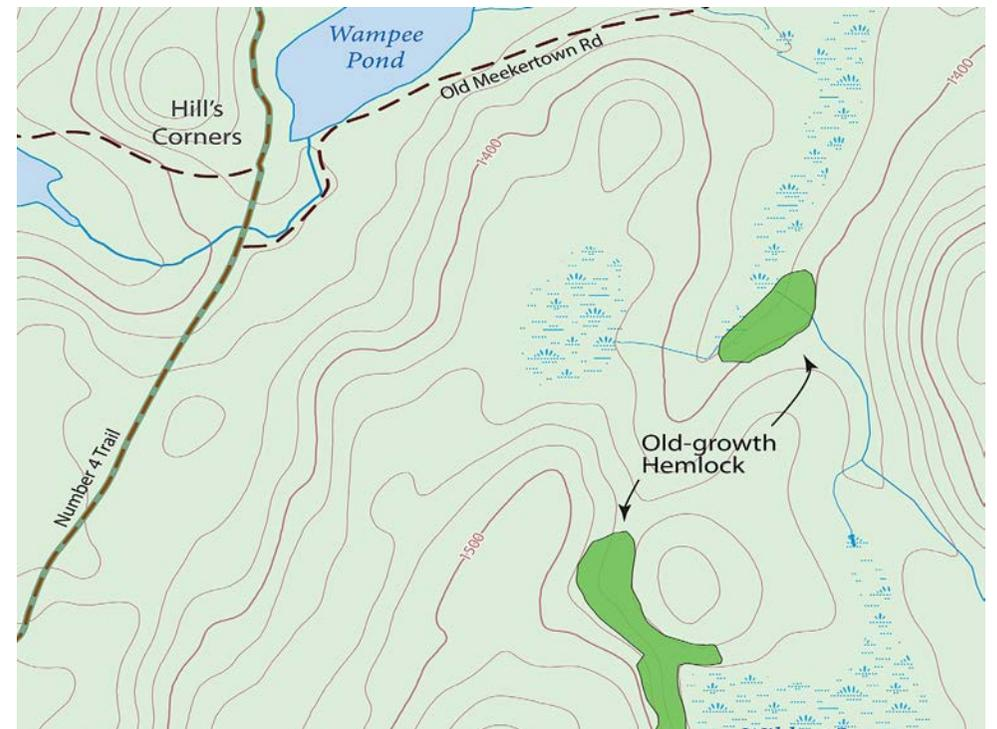
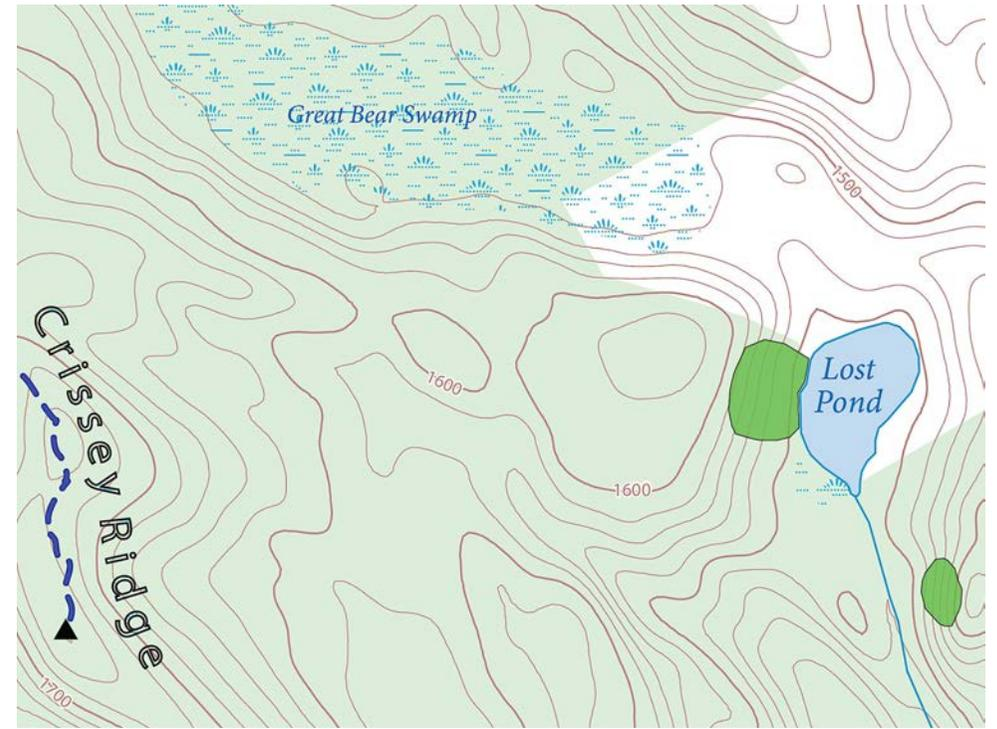
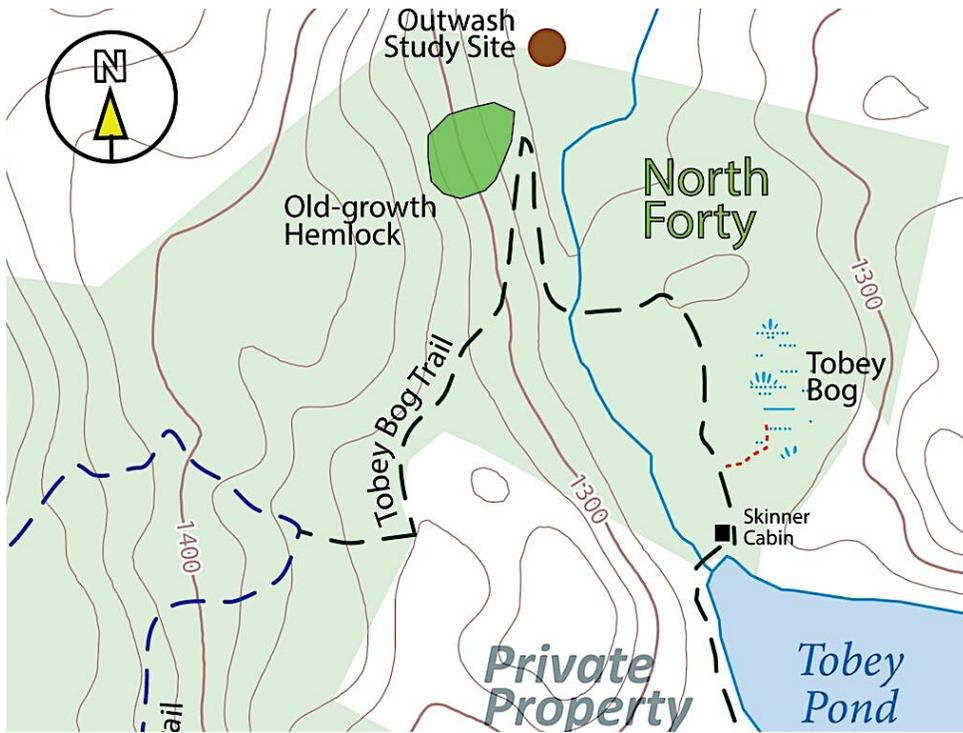

Locations of old growth communities. Clockwise from upper left: North 40; Lost (Dolphin) Pond; Long and Wildcat Swamps; Bigelow Pond.



Old Growth Hemlock forest on the west side of Wildcat Swamp. Note some of the trunks are sinuous, with gentle curves. This typically indicates trees over 250 years.



Old growth hemlocks and black birch (upper right) surrounded by mountain laurel near Wildcat Swamp.

late successional development). GMF contains several stands meeting one or all of these characteristics.

It is important to consider “old growth” as a continuum in space and time. A single 400-year old oak in a cleared meadow may be an “old growth” tree, but is clearly not a forest. Similarly, a 1000-acre forest of 200-year old trees that re-sprouted after a hurricane may also be considered “old growth.”

### Site Descriptions

*Lost (Dolphin) Pond:* Winer (1955) mentions 4-acres on the west-facing-slope, SE of the pond. We encountered scattered hemlocks reaching perhaps 200-years or more. The area had been logged around 1980, though it doesn't look like a lot of hemlock was harvested. The old growth area was poorly defined and occurs on a steep slope.

The second area, suggested to us by Russell Russ, occurs on the west side of Lost Pond. These hemlocks were more impressive in stature and undoubtedly attain greater age. Tree characteristics suggest 300+ years. Several trees are large reaching close to 40” in diameter. Heights are also impressive. A few coppiced hardwoods suggest logging approximately 100-years ago. Contemporary beaver activity was also encountered. Old

growth continued to the north edge of Lost Pond, though we did not map the exact extent.

*North 40:* This stand is probably the best known and most visited old growth site in GMF. It occurs along the gravel road near Tobey Bog. Old growth American beech and black birch also occur here. Many of the hemlock trees are tagged numerically for research. We did not map the extent of the stand but is believed to be only a few acres.

*Bigelow Pond:* east-facing slope on the west side of the pond. The hemlocks are impressive and old and they to spread on to adjacent TNC land. For this reason the extent of the stand was not mapped or explored thoroughly. Though the forest had been disturbed, individual old growth hemlock trees stretched away from Bigelow Pond for 100 meters or more.

Equally interesting, the entire slope to the east and southeast of Bigelow Pond contains numerous individual old growth hardwood trees and small stands of old growth hardwoods. With that in mind, the entire forest area is one of the more mature forest stands seen in GMF. Old growth tree species include: sugar maple, black cherry, red maple, yellow birch, and black birch. This area should be explored more thoroughly to determine disturbance history and stand ages.



Old growth tulip trees (left and right; young red oak in center). Tulip trees in New England are more typical on rich sites than acidic substrates, like the GMF plateau. No other mature tulip trees have been found. It raises the question of whether tulip tree had greater importance prior to intense cutting in GMF or if these two trees are a bizarre anomaly.

*Wildcat Swamp:* This stand is not described by Winer (1955). It was identified during field exploration. The stand may be the best and largest old growth site in GMF. The outstanding section, located along the steep slope to the west of Wildcat Swamp, contains mainly hemlocks that reach impressive size and stature. Green lichen on the trunks suggests trees of at least 350 years. The understory contains patches of mountain laurel, and open areas. Old growth yellow birch, also in the 350-400 year range also occurs. A coppiced red oak near the upper edge of the stand suggests logging disturbance approximately 100 to 150 years ago. Basal scars on a hemlock indicate fire occurred on the site decades or centuries ago.

The old growth's extent continues to the north in a lowland area and also includes the swamp itself. The swamp is dominated by hemlock and also contains red spruce and black gum. In the center of the swamp, a highland area contains large stature hemlock, centuries old. Mature spruce also occurs, as does pink azalea (*Rhododendron periclymenoides*) only seen here at GMF.



LEFT: Old growth black cherry. As black cherry ages, the corn-flake bark becomes tighter and less flakey. RIGHT: Old growth eastern hemlock with green crustose lichen on the bark. Hemlock bark is exceptionally tannin rich and typically wards off epiphytic growth. After about 350 years, however, lichens are able to colonize the bark. The presence of such lichen indicates trees approximately that age or older.

*Long Swamp:* This stand occurs on a westerly slope at the SE end of Long Swamp and is 3-acres according to Winer (1955). He states this stand shows no sign of cutting. We identified an old growth stand larger than three acres, but we did not map the extent of the stand with detail. The stand is mainly hemlock with some black birch and many standing dead American chestnut snags. Tom Wessels, referring to the density of ancient trees in this site, called it "the nicest stand of old growth hemlock in New England."

### Individual Old Growth Trees or Groups of Trees

Individual old growth trees occur occasionally in GMF. Features to look for include: rugose bark; crooked canopy branches; canopies resembling celery-tops; sinuous trunks; and large size. See Pederson (2010) for description on identification of old trees.

## Importance

Old growth trees and forests are relatively rare in New England. With trees and small stands reaching 400-years, the sites are inspiring as much as they are interesting. Hemlocks take on a sentinel appearance more characteristic of western US forests.

Discussion concerning the dichotomy of nature and culture, what old growth is, the presettlement landscape, and whether we should manage for old growth could occur when groups explore these trees. Though such a discussion would occur in a small New England forest, the conversation is of global relevance. Philosophy and science meet here among ancient trees.

## Nearby Sites

Outside GMF it is worth visiting Cathedral Pines, in nearby Cornwall, Conn. The 42-acre stand of former old growth white pine and hemlock was toppled by a tornado on July 10, 1989 although a smaller portion remains. The site was considered among the best “old growth” sites in New England. Patterson and Foster (1990) detail Cathedral Pine’s human and natural disturbance history; most trees date to pasture abandonment around 1800. The site is owned and managed by The Nature Conservancy.

## Research Ideas

Forest response to hemlock decline caused by the hemlock wooly adelgid. Epiphytic lichens in old growth hemlock trees.

Soil ecology in old growth forests.

Characterization and disturbance history of mature forest (including old growth hemlocks and hardwoods) between Bigelow Pond and Great Bear Swamp.

## Resources

Winer, H. 1955. *History of Great Mountain Forest. Dissertation, Yale University.* P110-125 old growth.

Patterson, W. and D. Foster. 1990. *Tabernacle Pines: the rest of the story. Journal of Forestry.* December 1990: 23-25.

Pederson, N. 2010. *External characteristics of old trees in the eastern deciduous forest. Natural Areas Journal* 30(4): 396-407.

Hilbert, J and A. Wiensczyk. 2007. *Old-growth definitions and management: A literature review. BC Journal of Ecosystems and Management,* 8(1): 15-32.

## NATURAL COMMUNITIES 4: BALDS AND ROCKY OUTCROPS

### Summary

Great Mountain Forest’s balds, barrens, and unique rocky outcrop communities are small in extent but provide one of the few naturally open environments found in the northeast. Such environments are characteristically dry, acidic, and offer limited soil, creating challenging conditions to which many species have adapted. And for the human visitor, they offer berries, sun, and at times, views. Some of these lichen communities are 200 years old – old growth just like the towering hemlocks.

GMF and adjacent portions of Housatonic State Forest provide 5 sites (listed here) for exploring and studying outcrop and bald communities. Each is unique and slightly different in its composition and environmental setting. Opportunities for research on these poorly understood communities abounds. Caution: These are exceptionally fragile communities and not ideal for large groups. Some contain rattlesnakes.

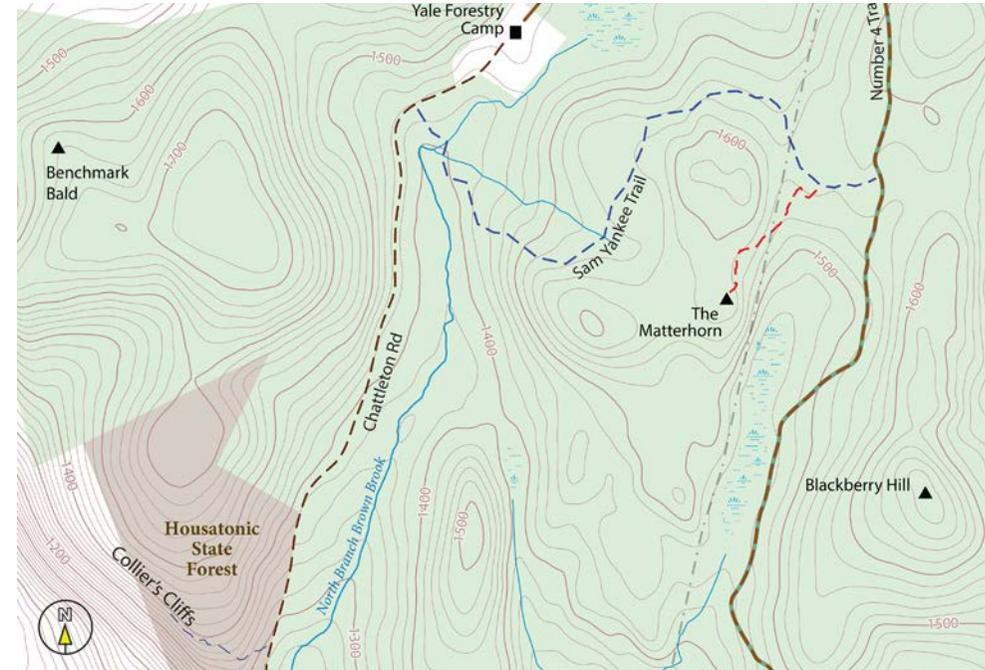

Map showing the four rocky outcrop communities nearest to Yale Camp. The Stoneman Mountain sites (not shown) are all located along the trail to the summit of Stoneman.

## Access

The easiest sites to access include: 1) Matterhorn, via Sam Yankee Trail; 2) Blackberry Hill, via #4 Trail and bushwhack; and 3) Stoneman, via the Stoneman Trail.

## Location

*Stoneman:*

Summit: 41°57'27.20"N 73°16'57.43"W Views of the Housatonic Valley and beyond

*Lower balds:* 41°57'42.11"N 73°16'55.20"W; 41°57'48.02"N 73°16'51.55"W; 41°57'50.68"N 73°16'45.48"W

*Blackberry Hill:* Limited views from either summit

*South Bald:* 41°56'16.06"N 73°14'59.65"W

*North Summit:* 41°56'18.26"N 73°15'0.63"W

*Collier's Cliff:* 41°56'8.20"N 73°16'15.87"W Excellent views of the Hollenbeck Valley

*Matterhorn Area:*

*Matterhorn:* 41°56'33.89"N 73°15'20.82"W Nice views toward Blackberry Hill

*Benchmark Bald:* 41°56'44.42"N 73°16'28.01"W (Not visited, views not known)

## Description

The processes responsible for creating and upholding rocky outcrop communities at GMF begins with the most recent glaciation. Up until about 15,500 years ago, glaciers scoured and sculpted the hills of New England into ridges, domes, and cliffs. Disturbances, including fire, have prevented soil development ever since and it is the lack of soil that keeps rocky outcrop communities bald and barren. A lack of disturbance would allow soil to form, deepen, and provide substrate for shrubs and trees leading to the closed canopy forest we find over most of the region today.

The thin soil environment does not retain moisture well and plants must adapt to these challenging conditions. They do this, in part, by emphasizing root growth over stem and branch growth. This enables plants to live within the means of the limited available moisture and low nutrients of dry, acidic, balds. We see this in the structure of the oaks and other trees

on GMF balds: stunted growth, twisted branches, pruned canopies.

On the ground we see additional adaptation to the dry, thin-soil environment. Lines of vegetation traverse patches of open bedrock. These crevice communities form in bedrock cracks in which soil accumulates and moisture retained. Beginning with lichens, and then moss, graminoids, herbs, and shrubs, the degree of colonization of a crevice will depend on the depth and moisture retaining abilities of the soil. As vegetation develops, additional soil is created and trapped within the plants. This creates a feedback-loop where additional plant growth leads to additional soil, and so-on until a disturbance resets the clock. The succession process can be summed, perhaps over simplistically with: crustose, foliose, fruticose, to forest.

The remaining bedrock is typically lichen-covered by all three common lichen forms. Crustose lichens are flat growths and nearly



**Outcrops and balds on Stoneman Mountain. The red line is GMF boundary, and the bald-speckled Stoneman Mountain is largely on Housatonic State Forest. It contains a trail, which begins on GMF property. Stoneman contains the largest and best outcrop communities within the GMF area, and northwest Connecticut more generally. The road at right is Canaan Mountain Road. Orientation is looking north.**

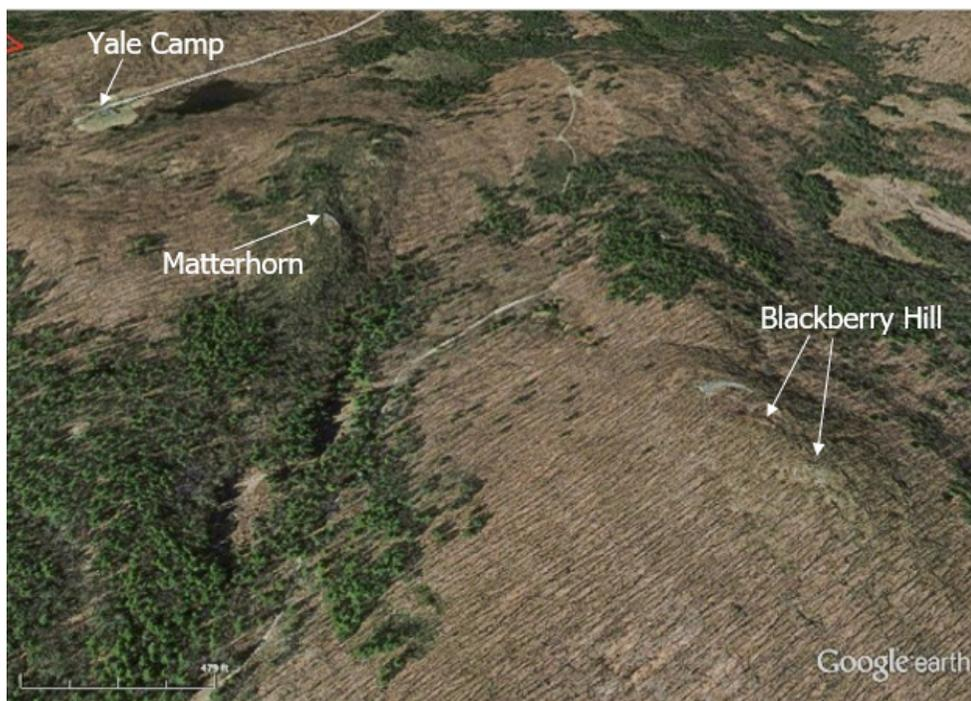

Rocky outcrops near Yale Camp. The #4 Trail bisects the image down the middle. Orientation looks north. These two balds are smaller in extent than Stoneman.

impossible to remove from the rock. Foliose lichens look more leaf or foliar-like, but are still rather two-dimensional. Fruiting lichens are more three-dimensional in structure. All except crustose lichens are fragile and are crushed when walked on. This is especially true in dry weather when the lichens are in a stiff cryptobiotic state. When wet, lichens soften and are not as easily destroyed. Use caution when walking among lichens communities. Some pincushion lichen communities at GMF are at least 200 years old (old growth) and Tom Wessels considered them to be exemplary for New England.

One should pause to consider the processes taking place: the glacially created rock communities, slowly forming soil, with periodic setbacks by disturbance. As with most natural communities, the physical landscape (geology, topography, climate) shapes the biological response.

The human history of these communities in GMF remains unclear. Though they have been open for centuries, it's possible they were more (or less) open prior to the cultural landscape change from indigenous Americans to European-Americans. The role of fire in both cultures,

and cutting in the latter culture, would have had an effect on these rocky communities. Coppiced trees, though small in diameter, show that one of the two disturbances has occurred recently. Nonetheless, both disturbances have played a role.

On the following page is a list of species identified during our brief reconnaissance. This list is not complete. Many graminoids and lichens were unknown. Additional botanical work should be done. Lichen diversity, in particular, should be documented.

Eastern red cedar is an interesting presence at Collier's Cliff. Cedar typically indicates more alkaline soils and it is possible that this site, on the western edge of GMF, is being influenced by the marble and/or limestone of the Hollenbeck and Housatonic Valleys.

Some characteristic bald communities found regionally, including pitch pine and scrub oak communities, do not occur on the balds of GMF. Neither of these species is found on GMF or adjacent balds. They are found locally on similar sites.

#### CAUTION

These sites contain fragile pin-cushion lichen communities that should be entered with caution. When stepped on during dry weather 200 year old *Cladonia* lichens can be crushed. Every effort should be made to remain on the trail, and if no trail exists one should remain only on open bedrock or other vegetation. Stoneman is inhabited by timber rattlesnakes.

#### Importance

Rocky Outcrop and Bald communities provide important landscape structure in an otherwise forested region. The sunny, warm, dry environment is wildlife rich. In the case of Stoneman Mountain, the community provides important habitat to timber rattlesnakes, especially during spring. Additional rare plants may also be present. Some areas of Stoneman and undescribed locations in GMF are old growth lichen communities and approximately 200 years old.

#### Nearby Sites

Nearby Mt Everett and Race Mountain in SW Mass., provides a similar, though higher elevation environment containing old-growth pitch pine communities. A small outcrop community occurs uphill from the Rich Talus Slope. The trail up Stoneman contains several points of interest.

## Research Ideas

Fire and disturbance history on rocky outcrops and balds.

Succession on rocky outcrops.

Wildlife use of rocky outcrops and balds by patch size.

Lichen colonization and succession.

Human history of balds and outcrops in GMF or more broadly.

Trampling by humans in bald communities.

SPECIES	COMMON NAME	NOTES
<i>Quercus rubra</i>	Red Oak	
<i>Quercus velutina</i>	Black Oak	Probably most common
<i>Quercus alba</i>	White Oak	
<i>Quercus montana</i>	Chestnut oak	
<i>Pinus strobus</i>	White pine	
<i>Prunus virginiana</i>	Choke cherry	
<i>Amelanchier</i> sp.	Serviceberry	
<i>Juniperus virginiana</i>	Eastern red cedar	
<i>Vaccinium stamineum</i>	Deerberry	Specific to rocky sites
<i>Vaccinium angustifolium</i>	Low-bush blueberry	
<i>Gaylussacia baccata</i>	Huckleberry	
<i>Diervilla lonicera</i>	Bush-honeysuckle	not to be confused with exotic shrub honeysuckles ( <i>Lonicera</i> sp.)
<i>Hypoxis hirsuta</i>	Yellow star-grass	
<i>Rubus flagellaris</i>	Dewberry	
<i>Schizachyrium scoparium</i>	Little bluestem	
<i>Tridentalis borealis</i>	Starflower	
<i>Polytrichum</i> sp.	Haircap moss	Found on dry sites or mineral soil
<i>Stereocaulon</i> sp.		Lichen
<i>Cladonia</i> sp.	Reindeer lichen	several species of <i>Cladonia</i> occur
<i>Xanthoparmelia</i> sp.	Rock shield lichens	
<i>Umbilicaria</i> sp.	Rock tripe	



Outcrop community at Collier's Cliff on State Forest lands adjacent to GMF. Haircap moss, grows with oak seedlings and lowbush blueberry among lichen-covered bedrock. This site has excellent views of the Hollenbeck Valley.



A crevice community at the summit of Blackberry Hill in GMF. The well-developed community contains a variety of mosses, lichens, grasses, and blueberry. As plant parts and rock fragments continue to break off and become trapped among the vegetation, soil develops and more vegetation will grow.



A broad expanse of almost 2-acres of open, bedrock-dominated barren community on the Stoneman Trail. Scattered trees (oaks and pines here) grow where roots can penetrate. Lichens, mosses, herbs and grasses cover the still rocky areas. Regular disturbance from fire helps these communities thrive.



A band of *Cladonia sp.* lichens among graminoids and boulders on the south bald of Backberry Hill. The band of lichens spans an area lacking soil, while vascular plants cover more soil rich areas. A patch of hay-scented fern occurs in the background. The rocks were left by glaciers and are also covered in lichens.

## Resources

McMullin, T. and F. Anderson. 2014. *Common Lichens of Northeastern North America: A Field Guide*. New York Botanical Garden Press.

Wessels, T. 2001. *The Granite Landscape: A Natural History of America's Mountain Domes, from Acadia to Yosemite*. Countryman Press.

Gaige, M. 2015. *Short, bald, and beautiful: the New England open summit*. AMC Outdoors. [Link](#).

Swain, P.C. & J.B. Kearsley. 2001. *Acidic Rocky Summit/Rock Outcrop*. In: *Classification of the Natural Communities of Massachusetts. Version 1.3. Natural Heritage & Endangered Species Program, Division of Fisheries & Wildlife*. Westborough, MA. [Link](#)

Hale, M.E. 1950. *The lichens of Aton Forest, Conn. The Bryologist* 53(3): 181-213.



A community of pin-cushion lichens on the Stoneman Trail. The *Cladonia sp.* lichens are very old and very fragile. Note the shrubs at right growing along a crevice community and the single young pine emerging in bedrock. How large can it grow?

## NATURAL COMMUNITIES 5: OAK WOODLANDS

### Summary

GMF's oak woodlands form distinctive, open, park-like communities quite unlike the tall, closed canopy matrix forest. These communities tend to occur on higher, southerly aspect, slopes with low-density canopy. The oak woodlands of GMF are southern in character and reach the northern extent of their range in central New England.

### Access

None are particularly close to road, nor are they close to trails. All need to be accessed by navigating off-trail.

### Location

1. *Across from Yale Camp*: 41°56'59.38"N; 73°15'46.07"W
2. *Near Collier's Cliff*: 41°56'8.20"N; 73°16'15.87"W
3. *Above Rich Talus Slope*: 41°56'37.73"N; 73°16'41.11"W
4. *Near summit above Dorman*: 41°56'36.97"N; 73°16'8.19"W
5. *South of Sam Yankee Trail*: 41°56'30.98"N; 73°15'32.73"W
6. *South side of Blackberry Hill*: 41°56'14.96"N; 73°15'0.66"W

### Description

Natural community definitions typically divide oak woodlands, and other similar communities into distinct eco-types. For example, the Commonwealth of Massachusetts recognizes the following: Hickory-hop hornbeam forest/woodland; Oak-hickory forest; Open oak woodland/forest; and Ridge top chestnut oak woodland. Here, because such communities are somewhat uncommon, and our examination of them was cursory, we are treating them more broadly, as sub-xeric, oak-dominated woodlands. It is worth noting the distinction between woodland and forest: a forest, generally, has a denser canopy than more open woodland. Some authors rank woodlands as having 50% to 75% canopy cover while a forest would have 75% or greater cover. In GMF, the oak-dominated communities discussed here tend to have shorter, more widely spaced trees akin to woodlands by many definitions.

GMF's dry woodlands are dominated by red oaks with some areas having black oak. In the drier sites chestnut oak is common. Many of these trees are coppiced, a result of charcoaling and/or fires. Shagbark and pignut hickory can also be common, along with hop-hornbeam. At

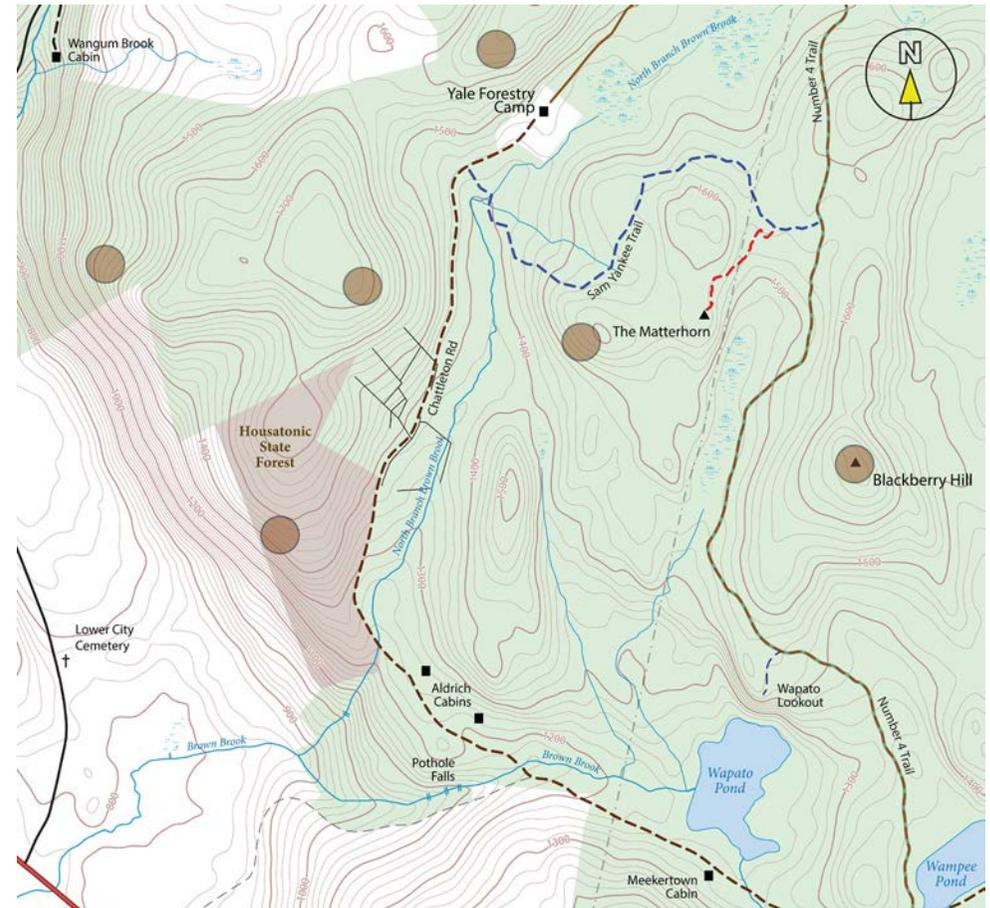

Map of oak woodlands communities.

times, white oak can attain a significant percentage of the understory composition. Where they occur on upper slopes near summits and soil is thin and bedrock close to the surface, the trees take on an elfin and stunted appearance, an adaptation to limited soil moisture and nutrients as well as canopy damage from summit exposure.

Oak woodlands occur at higher elevation on GMF, where soils are thin and sites dry. These are best represented on higher, south-facing slopes. Fire may have been a significant ecological process in these communities prior to Euro-American settlement. Fire would maintain the sites in a dry, low soil, open understory, graminoids-oak community. Many sites today would benefit from a woodland fire.

Colliers cut oak-hickory woodlands heavily during the charcoaling days. Hearths can be found in and around them today.

Below is a list of species identified during our brief recognizance. This list is not complete. Many graminoids and lichens were unknown. Additional botanical work should be done. Lichen diversity, in particular, should be documented.

SPECIES	COMMON NAME	NOTES
<i>Quercus rubra</i>	Red Oak	Common, frequently coppiced
<i>Quercus alba</i>	White Oak	uncommon
<i>Quercus montana</i>	Chestnut oak	uncommon
<i>Castanea dentata</i>	American Chestnut	
<i>Carya ovata</i>	Shagbark hickory	
<i>Carya glabra</i>	Pignut hickory	Could be <i>C. ovalis</i> , <i>C. tomentosa</i>
<i>Ostrya virginiana</i>	Ironwood	
<i>Vaccinium angustifolium</i>	Low sweet blueberry	
<i>Kalmia latifolia</i>	Mountain Laurel	
<i>Acer rubrum</i>	Red Maple	Invading these xeric woods
<i>Gaylussacia baccata</i>	Black Huckleberry	
<i>Amelanchier</i> sp.	Serviceberry	
<i>Deschampsia flexuosa</i>	Hairgrass	
<i>Carex pensylvanica</i>	Pennsylvania sedge (aka: Oak Sedge)	common ground cover in oak woodlands

### Importance

These warm-sited communities are not well understood particularly with regards to the role of fire. Their open, park-like nature offers an appealing environment for walking.

### Nearby/Related Sites

In several places balds and rocky outcrops occur among oak woodlands. The balds are simply a drier more xeric community along the spectrum. Coppice and charcoal hearth sites also typically occur among oak woodlands.

### Research Ideas

The role of fire in maintaining oak woodlands.

Stand ages in oak woodlands (charcoal logging is dateable through coppice trees)

Mesification: the increase of maples and other mesic-sited plants in formerly xeric locations due to fir suppression.

### Resources

Swain, P. 2011. *Open oak forest/woodland. Natural Heritage & Endangered Species Program, Massachusetts Division of Fisheries & Wildlife. Link*

Mickelson, John. 2000. *Great Mountain Forest Conservation Evaluation. Unpublished report by: The Nature Conservancy.*



An oak-hickory woodland on the south side of Blackberry Hill. The ground is dominated by Pennsylvania sedge. Note the open understory and lack of full canopy.



Oak hickory woodland on the south side of Blackberry Hill. Note the coppiced tree in center, open understory.



Oak-sedge woodland near the Jean Trail and the harvest along the slope to the east. Many dry oak sites occur on ridges like this one.



Open oak woodland near Yale Camp. Note the coppiced white oak in center. It was cut ~100 years ago during the charcoal days.



A chestnut oak woodland on thin bedrock soils. Trees are short stature as they invest in roots. The trees are older than is expected of their size due to the poorer conditions.



Oak woodland near the summit above the Dorman site. The bedrock emerging here shows how the soils in these dry communities are thin, and where it is too thin, trees fail and low plants, mosses, and lichens dominate.



Oak-hophornbeam woodland in the western extent of GMF. This site occurs high above the talus community.

## NATURAL COMMUNITIES 6: MIXED APPALACHIAN FOREST

### Summary

This site probably displays the highest native tree diversity in Great Mountain Forest with at least 20 tree species over less than 10 acres (5-acres for core area). Shrub and herbaceous diversity is also high. The site could be considered an extension of the Rich Talus Community (this section), but composition and structure is different enough, and the sites are distant enough, that it is listed separately. The site also contains a large block of Stockbridge Marble, several charcoal hearths, and a timber harvest from 2000.

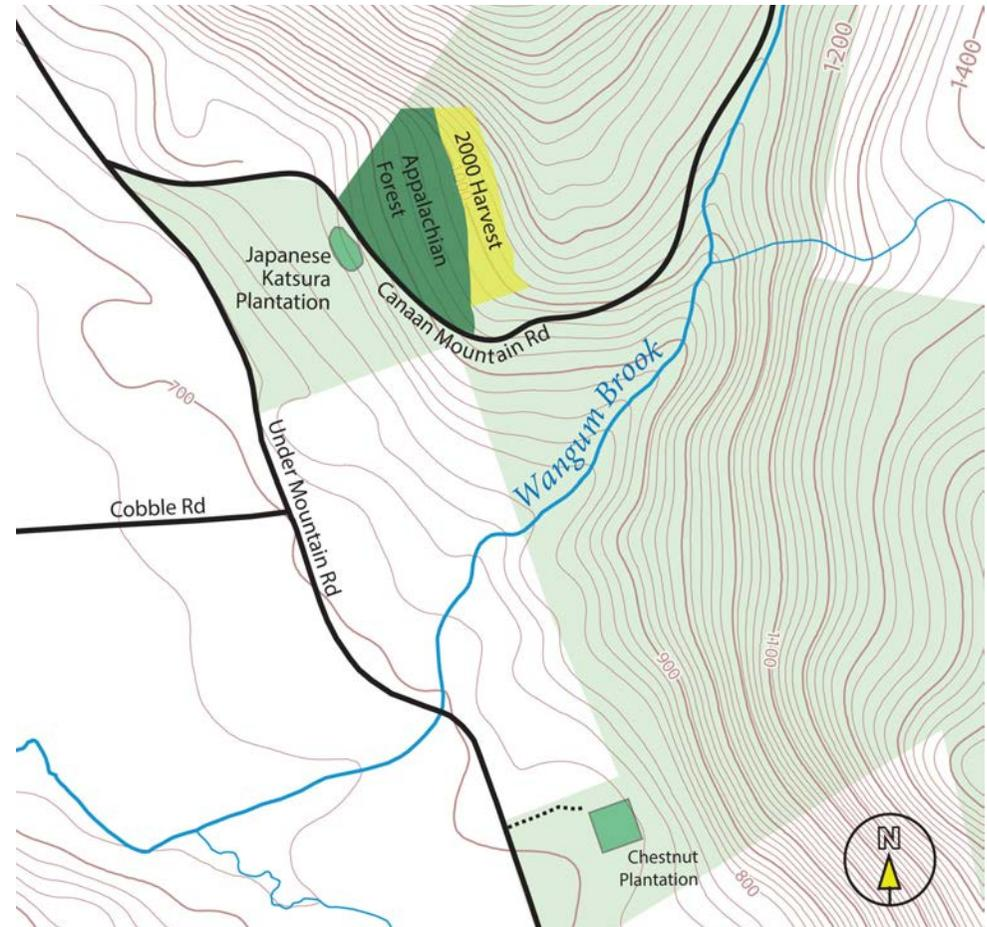

Location of Mixed Appalachian Forest.

### Access

The site is easy to get to and has room for ~3 cars on the downhill side of Canaan Mountain Road near a bend in the road with a guardrail. Coordinates for parking are: 41°56'54.85"N; 73°17'7.52"W

### Location

Site: 41°56'59.86"N; 73°17'9.65"W

Hearth: 41°57'0.75"N; 73°17'7.48"W

Hearth 2: 41°57'2.65"N; 73°17'7.12"W

### Description

Geological maps indicate this site lies above the margin of Stockbridge Marble and the rich soils created by that rock type. A large marble or limestone block, however, presumably of glacial origin, occurs on site, and with the vegetation indicates rich soils. The marble block must have been glacially deposited. Mickelson (2000, p. 8) suggests these soils are richer “due to both calcareous bedrock influences and telluric (sub-surface water) nutrient input.” He further states: “Heightened soil and air temperatures exist due to west facing light and radiation gain as well as upslope air currents. These conditions favor high biodiversity due to intermixing of communities found more commonly in southerly climates with those found in cooler northern systems.”

The area comprises only ~10 acres on GMF lands, though a variation of it continues upslope on a steep, rocky talus and cliff environment. Large coppiced trees (red and chestnut oaks, tulip poplar) and charcoal hearths (see hearths in Land Use section) indicate the site’s use for charcoal production. The size of the trees suggests robust productivity. The trees would have been last cut in the late 1800s or earliest 1900s during the charcoal era.

Additional disturbance occurred immediately above the site in 2000. The area was logged and now contains dense regeneration of early successional hardwoods. The cutting defines the upper limit of this community. The flatter bottomland below and Canaan Mountain Road defines the lower limit. *Wisteria* sp. is invading along the road edge and therefore believed to be exotic (Asian) and not the native species.

On this page is a partial species list from this site taken in August and therefore lacking spring ephemerals that should be present. This was a rapid assessment and a more thorough inventory on this highly diverse site should be conducted.

Species observed at the Appalachian Forest site in GMF.	
COMMON NAME	SPECIES NAME
Sugar maple	<i>Acer saccharum</i>
Red maple	<i>Acer rubrum</i>
Black birch	<i>Betula lenta</i>
Shagbark hickory	<i>Carya ovata</i>
Bitternut hickory	<i>Carya cordiformis</i>
Pignut hickory	<i>Carya glabra</i>
American chestnut	<i>Castanea dentata</i>
American beech	<i>Fagus grandifolia</i>
White ash	<i>Fraxinus americana</i>
Tulip tree	<i>Liriodendron tulipifera</i>
Hop hornbeam	<i>Ostrya virginiana</i>
Black cherry	<i>Prunus serotina</i>
White Oak	<i>Quercus alba</i>
Chestnut oak	<i>Quercus montana</i>
Red oak	<i>Quercus rubra</i>
Eastern hemlock	<i>Tsuga canadensis</i>
White pine	<i>Pinus strobus</i>
Basswood	<i>Tilia americana</i>
Paper birch	<i>Betula papyrifera</i>
Sassafras	<i>Sassafras albidum</i>

COMMON NAME	SPECIES NAME
Hog peanut	<i>Amphiocarpaea bracteata</i>
Wild sarsaparilla	<i>Aralia nudicaulis</i>
Naked tick-trefoil	<i>Hylodesmum nudiflorum</i> *
Wood fern sp.	<i>Dryopteris</i> sp.
Bedstraw sp.	<i>Gallium</i> sp.
Dwarf ginseng	<i>Panax trifolius</i>
Virginia creeper	<i>Parthenocissus quinquefolia</i>
Spicebush	<i>Lindera benzoin</i>
Maple-leaf vibur.	<i>Viburnum acerifolium</i>
Maidenhair fern	<i>Adiantum pedatum</i>
Witch-hazel	<i>Hamamelis virginiana</i>
Hanukkah fern	<i>Polystichum acrostichoides</i>
Grape	<i>Vitis</i> sp.
Beaked hazelnut	<i>Corylus cornuta</i>
Wisteria	<i>Wisteria</i> sp.*^
* Needs confirmation	
^ Exotic	



The Appalachian Forest. This site is the GPS point provided above. Here the forest backs up against the steep talus cliff (and also GMF property). This is a scenic, diverse, natural area and cultural landscape. Note the copped tulip tree at left. That, sugar maple, ash, and others showcase the site's richness.

### Nearby/Related Sites

From the parking area, the opposite side of the road contains the Katsura plantation (with dawn redwoods, white fir, and tulip trees). The bottomland is an old-field white pine stand selectively thinned in the 1980s. Additional charcoal hearths occur along the road. See Charcoal Hearths in the Land Use History section.

### Research Ideas

How does this site compare to the Rich Talus Slope in total vegetation diversity and soil properties?  
 What year was the last charcoal cutting?  
 What are the growth rates for trees on this site and how does that compare to other sites in GMF?

### Resources

Mickelson, John. 2000. *Great Mountain Forest Conservation Evaluation*. Unpublished report by: The Nature Conservancy.

In addition to the three charcoal hearths in the forest, there is another hearth along the road that displays a cross-section of the soil profile for a charcoal hearth. This is an interesting feature that warrants observation as charcoal hearths contain unique soil properties. See charcoal hearth discussion in the land use history section.

An old trail called the Military Road traverses this area and is discernable. Local lore has it that supplies such as canon balls and tools were delivered to Burgoyne's army.

### Importance

With 20 species of trees over just a few acres, this site likely has the highest tree diversity in GMF. Herbaceous diversity should also be high, but our visit was cursory and late season. This combined with charcoal hearths and other history makes it a top site at GMF. **Caution:** this area occurs in known rattlesnake habitat.



A rich charcoal hearth site at the Appalachian Forest. Here along the margins of a charcoal hearth, maple-leaved viburnum, maidenhair and wood ferns, and oddly, an American chestnut, grow. White ash in the photo is notable as an uncommon tree in GMF.



A block of Stockbridge Marble in the Appalachian Forest. At front is a coppiced chestnut oak, cut in the charcoal era around 1900. Several hearths are nearby. The marble is covered in maidenhair fern, hepatica, and other rich site indicators. The block is located between the parking area and the GPS point listed for the site.

## NATURAL COMMUNITIES 7: TOBEY BOG

### Summary

The only true peatland within the Great Mountain Forest, and one of only a few within all of Connecticut. A floating mat of sphagnum moss hosts a fascinating array of plant species within a closed, nutrient poor system.

### Access

Tobey Bog can be reached by walking through the Charcoal trail near the East Gate entrance of the Great Mountain Forest. Please contact GMF staff if vehicle access is needed, as all roads to the bog are private.

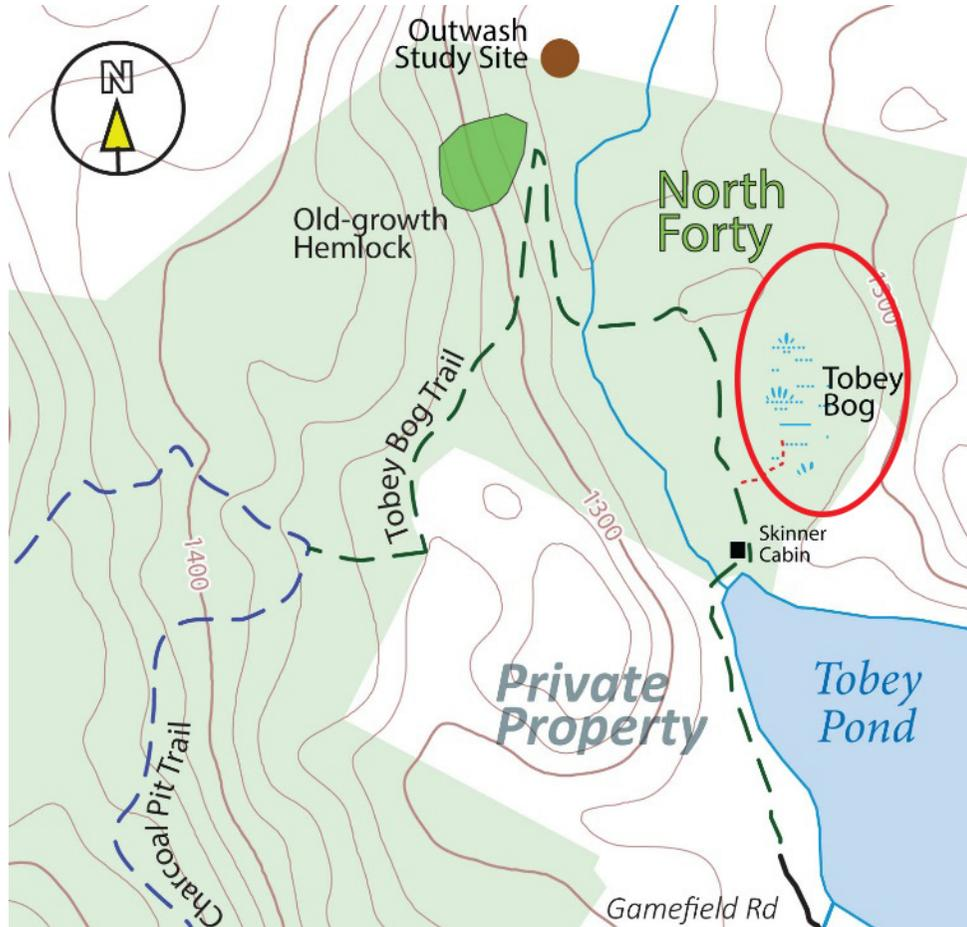

Map of the location of Tobey Bog.

### Location

*Tobey Bog*: N 41°58'42.56"; W 73°13'32.12"

### Nearby or Comparable Sites

Though a different classification of wetland, Tobey bog shares many characteristics and species in common with the red spruce swamps found elsewhere in the Great Mountain Forest (see Natural Communities 2). It is near to the Tobey Pond public beach, as well as the Norfolk Curling Club to the east.

### Description

#### *Bog Ecology*

Bogs are nutrient poor wetlands that are closed (or at least mostly closed) to any source of drainage. In such environments, waste products cannot leave the system, resulting in high acidity levels and strong selection for a specialized cohort of plant species that are adapted (sometimes uniquely so) to such harsh conditions. Bogs are defined by their thick carpets of *Sphagnum* mosses—sometimes thirty feet or more deep—whose slowly decaying remains form the bulk of the substrate upon which all other plants take root and grow. Common groups of these species include stress tolerant conifers, shrubs from the heath family (*Ericaceae*), and an impressive diversity of sedges (*Carex* sp.). Together with visiting wildlife, they comprise unique ecosystems whose continued existence depends on a tenuous set of specific site conditions.

Though identified by similar characteristics, there are a number of recognized bog types, distinguished into categories by differences in plant community composition, origins, and water source. In order to continue accumulating slowly decomposing peat inputs, bogs must gain water at a faster rate than it is lost from the combined effects of evaporation and plant respiration. Ombrotrophic bogs are completely isolated systems that receive water only from the atmosphere in the form of rain or snow. These only occur from Maine northwards, where the cooler temperatures restrict the loss of water from surface evaporation. Minerotrophic bogs are a group of peatland types that receive additional water inputs from auxiliary sources, such as ground water tables (topogenous), occasional flooding from nearby lakes and slow-flowing streams (limnogenous), or from seepage water (soligenous). Minerotrophic bogs tend to have greater concentrations of nutrients than ombrotrophic bogs because water that travels along or through the ground is able to accumulate elements from eroding rocks and



A sprawling high bush blueberry (*Vaccinium corymbosum*) growing in the thickest part of the bog. It thrives in acidic, nutrient poor sites, much like other members of its family (the Ericaceae).

soil particles. They are found across a variety of landforms, often in sandy or gravel filled areas within valleys or along coastal plains where water can accumulate in landscape depressions. Elsewhere, bogs occur in depressions that are underlain with a layer of glacial till deposits atop more compacted till or metamorphic bedrock to create a raised water table.

The key to bog formation is that the level of production by the collective plant community is greater than the rate of decay. In such systems, the partially decomposed leaf litter and dead roots accumulate to form the deep peat structure. The Sphagnum moss, which tends to form the bulk of this mass, grows continually upwards and dies at the bottom, where the weight of new vegetative inputs presses it down deep below the surface. This cycle results in the formation of two distinct peat horizons. The acrotelm is the surface peat that sits above the low water table, where there is still some amount of oxygen. It is the site of water storage for vegetation throughout the year, its retention capability determined by the depth and structure of the peat itself. The catotelm is the lower peat, which



View of the walkway into Tobey Bog. The wooden planks are not nailed to anything, just lain atop the thick floating mat of *Sphagnum* moss. Don't worry about sinking, though it may sag a bit.



View of the pitcher plants in flower. The flowers are raised high above the pitcher mechanism, possibly to avoid accidentally trapping any potential pollinators (primarily bees).



Close up of sundew (*Drosera rotundifolia*). Insects become trapped on the glandular tentacles on its leaves, where they are then digested by the plant.

is constantly water saturated and anaerobic. Flow between these horizons occurs in the lower portion of the acrotelm, where the water table rises and falls in accordance with seasonality—lower in the hot summer months when water loss can exceed accumulation, and higher during the other seasons when the opposite is true. Through the parallel processes of gravity bringing water to percolate down through lower levels, and evaporation bringing it back up to the surface, the actively growing surfaces of bogs can usually maintain more or less average moisture saturation throughout the year.

Bog vegetation is restricted to communities of stress adapted wetland species, but they can vary in composition based on the structure and geographic location of the bog, as well as position within the bog itself. Bog forests tend to proliferate most vigorously along the borders, though individual trees of varying sizes can grow throughout. Species like red maple (*Acer rubrum*), eastern hemlock (*Tsuga canadensis*), and northern



Panorama view of Tobey Bog from the end of the wooden walkway. Note the stunted black spruces in the foreground, unable to grow very tall due to nutrient limitations in the bog substrate. Illustration by Autumn Von Plinsky.

white-cedar (*Thuja occidentalis*) dominate in relatively eutrophic (nutrient rich) seepage water-fed bogs. In more acidic, nutrient poor bogs, American larch (*Larix laricina*), black spruce (*Picea mariana*), and red spruce (*Picea rubens*) tend to be the most abundant tree species. The shrub layer, with extensive, spreading root systems, is often the most vigorous horizon of growth. Thickets of high bush blueberry (*Vaccinium corymbosum*), clammy azalea (*Rhododendron viscosum*), mountain holly (*Nemopanthus mucronata*), huckleberries (*Gaylussacia dumosa*), leatherleaf (*Chamaedaphne calyculata*), and lambkill (*Kalmia angustifolia*), frequently flourish across the soggy peat landscape.

However, the most unique plant species exist in the bog's herb layer. To make up for the extremely low levels of nitrogen in the acidic Sphagnum substrate, these plants have developed carnivorous capabilities in order to acquire this vital nutrient from insects. The leaves of sundews (*Drosera* sp.) have sticky glandular hairs that trap and liquefy insect visitors. More sophisticated still is the selective insectivorous mechanism of the pitcher plant (*Sarracenia purpurea*). The modified leaves form a pitcher, which is filled with rainwater mixed with powerful plant exudates that attract and systematically dissolve certain species of insects. Others, such as the

midge *Metrocnemus knabi*, are not only unaffected by the pitcher fluid, but actually develop as larvae inside, feeding on the other trapped insects.

Though less abundant than in other habitats, birds and mammals are still an important component of bog ecosystems. Moose and deer make good use of the abundant shrub forage, particularly around the bog borders. Black bears are also frequent visitors, feeding on the high bush blueberries that are so abundant, and are also attracted to the relative cover that the brambles provide. The other major large mammal species found in bogs is the beaver, who sometimes builds lodges and dams in peatland centers. The subsequent flooding can greatly damage the fragile ecosystem, and the impacts can last for many years even after the beaver population has moved on.

Among the non-mammals, there are only a few species of amphibians and reptiles that can survive the acidic conditions of bogs. These tend to be more hardy, boreal associated species such as the wood frog, bog turtle, and spotted salamander. Conversely, many bird species, both of a boreal distribution but also from surrounding habitats, spend some or all of their time in bogs. These are typically passerine (tree

perching) birds, particularly the warblers who are often drawn to open or edge habitat. Certain species, such as the palm warbler and Lincoln’s sparrow, are highly site restricted, dwelling almost exclusively in bogs and related wetlands.

As with all sensitive ecosystems occurring within the Great Mountain Forest, it is important to consider the impact of human activity on the current and future health of bogs. The most immediate threat to bogs is systematic draining and destruction for the creation of resorts and housing developments, or the intentional damming to create lakes. Nutrient additions from nearby septic fields and surface fertilizers can seep into existing bogs, accelerating decomposition rates and thereby tipping the precarious balance of plant matter accumulation. The peat in bogs is also harvested in great quantities every year for mulches and potting mixes, and it can take decades for it to regenerate properly. Finally, bogs may be especially vulnerable to the impacts of anthropogenic climate change. As temperatures warm, decomposition rates within bogs may increase dramatically, even extending into the depths of the anaerobically preserved peat of the catotelm horizon. Globally, there is such a huge quantity of biomass stored in peatlands that their synchronized decomposition would release many tons of greenhouse gases into the atmosphere, thus catalyzing a dramatic feedback loop of accelerated decay and warming.

#### *Features of Tobey Bog*

Tobey Bog covers approximately 5 acres of land in GMF’s “North Forty”, just north of Tobey Pond. Though completely closed to aboveground water sources from stream flow and floodplains, it likely receives some nutrient rich seepage from adjacent ground water sources, as is common for peatlands that occur in southern New England. The growing substrate is a floating mat of sphagnum moss, apparently once measured to be 32 feet deep (Hamlin 1991). A wooden walkway extends about 50 feet from the road towards the center of the bog. In true bog fashion, the species composition shifts the farther one travels from the edge. The beginning of the pathway weaves through dense patches of highbush blueberry and the invasive glossy buckthorn (*Frangula alnus*). The midsummer visitor may thus treat herself to a tasty *Vaccinium* snack while examining the ground story vegetation of this thicket—intermingling patches of wild calla, arrow arum, with bog and fragile fern.

The pathway terminates in a more open area where the shrubbery grows less dense and the more acidic adapted species—pitcher plant,

sundew, and lambkill—become more abundant. Scattered throughout are stunted trees, red maple, larch, white pine, and black spruce, which are able grow in this environment, albeit not to their ecological potentials. The black spruce is particularly notable among these species. It is typical of boreal habitats much farther north, and Tobey Bog is the only place in the Great Mountain Forest where it is known to grow. Close inspection shows that some of these black spruce are being parasitized by *Arceuthobium pusillum*, a species of dwarf mistletoe that obtains its nutrients from the living tissues of the tree’s branches.

Tobey Bog is also the subject of “Bog Essays”, a 1991 masters thesis by Erica Hamlin. It is a series of creative scientific writing pieces that detail different topics of bog ecology, interspersed with charcoal drawings and ruminations about her own experiences wandering Toby Bog. It is a good reminder that strange ecosystems like bogs have the power to inspire people across disciplines and cognitive frames. Go there when you need to find some peace in your life, albeit of the soggy, acidic variety.

COMMON NAME	SCIENTIFIC NAME
Red maple	<i>Acer rubrum</i>
Eastern White Pine	<i>Pinus strobus</i>
Black Spruce	<i>Picea mariana</i>
American Larch	<i>Larix laricina</i>
High Bush Blueberry	<i>Vaccinium corymbosum</i>
Lambkill	<i>Kalmia angustifolia</i>
Glossy Buckthorn	<i>Frangula alnus</i>
Bog Rosemary	<i>Andromeda glaucophylla</i>
Round leaved sundew	<i>Drosera rotundifolia</i>
Pitcher Plant	<i>Sarracenia purpurea</i>
Wild Calla	<i>Calla palustris</i>
Arrow Arum	<i>Peltandra virginica</i>
Dwarf Mistletoe	<i>Arceuthobium pusillum</i>
Sedges	<i>Carex spp.</i>
Fragile Fern	<i>Onoclea sensibilis</i>
Cinnamon Fern	<i>Osmunda cinnamomea</i>
Bog Fern	<i>Thelypteris simulate</i>

## Resources

Damman, Antoni W. H., (1987) *The ecology of peat bogs of the glaciated northeastern United States: a community profile*. U.S. Fish and Wildlife Service Biological Report 85 (7.16)

Hamlin, Erica. (1991). *Bog Essays*. Thesis for Wesleyan University Master of Arts in Liberal Studies.

Johnson, Charles W., and Meredith Edgcomb Young (1985) *Bogs of the Northeast*. University Press of New England, Lebanon.

U.S.F.S Forest Insect and Disease Leaflet: *Eastern Spruce Dwarf Mistletoe* [http://www.na.fs.fed.us/pubs/fidls/ed\\_mistletoe/ed\\_mistletoe.pdf](http://www.na.fs.fed.us/pubs/fidls/ed_mistletoe/ed_mistletoe.pdf)

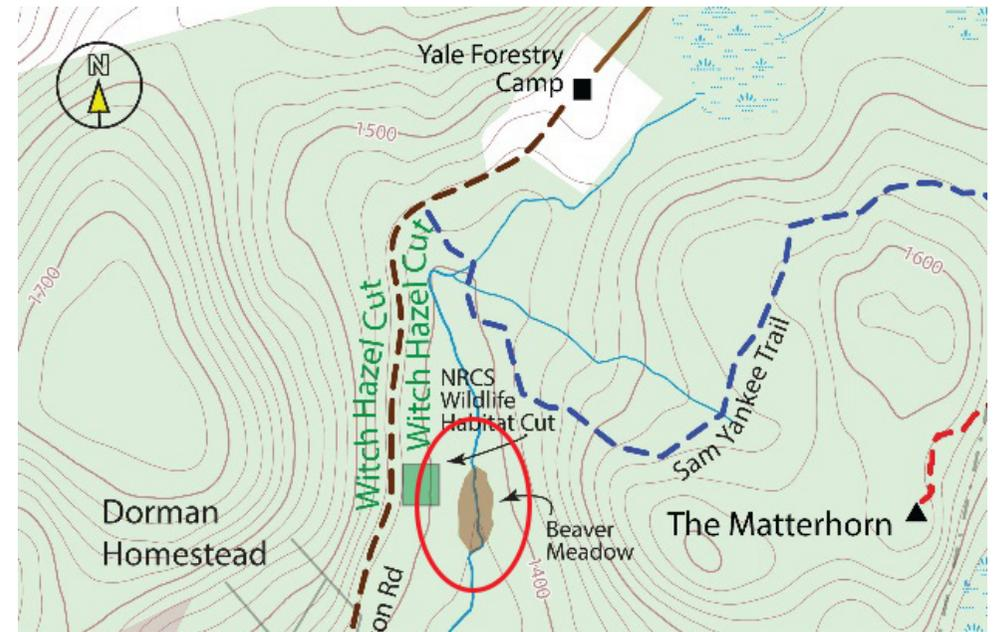

ABOVE: Map of Beaver Meadow. BELOW: Detail of Pitcher Plant.



## NATURAL COMMUNITIES 8: BEAVER PONDS

### Summary

Beavers are major shapers of the environment at GMF, impacting hydrology and forest composition. The cycle of dam creation and abandonment creates a patchwork of wetland types across the landscape. This section describes several sites of beaver activity, at varying levels of use and decay.

### Access

The beaver dam and lodge on Wampee Pond is accessible off the Number 4 Trail near the intersection with Old Meekertown Road in the southern part of GMF.

The recently abandoned dam sits in the middle of the wetland, located to the northwest of the Mountain House. Visitors may park on the grass near the intersection of Canaan Mountain Road and Wangum Road, and walk from there (bring muck boots!).

The beaver meadow site is east of Chatleton Road beyond the NRCS Wildlife Habitat Cut, a brief walk south from the Yale Camp.

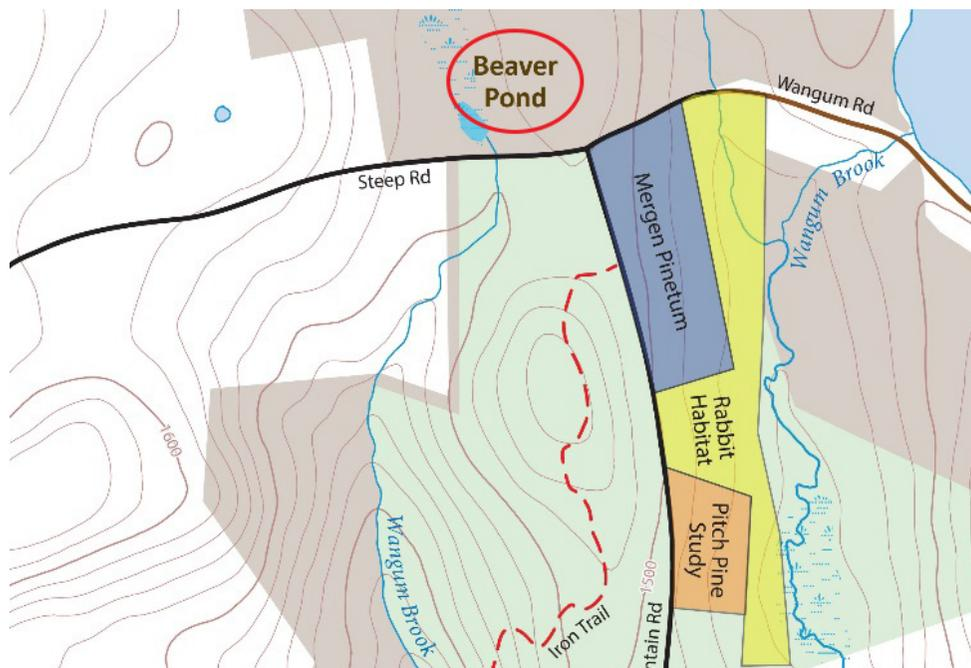

Map of Abandoned Beaver Pond.

Though all plants and creatures at Great Mountain Forest condition the environment to some extent, none (aside from perhaps humans) modify their habitat as drastically as the North American beaver (*Castor canadensis*). As previously described (see Species of Interest 17: Beavers), the recent resurgence of beaver populations in New England (and much of the continental U.S. and Canada) has caused a dramatic restructuring of local hydrology in protected areas like GMF.

### Location

*Beaver Meadow*

N 41°56'38.81"

W 73°15'49.38"

*Abandoned Beaver Pond*

N 41°58'27.23

W 71°16'30.29"



The active beaver lodge on Wampee Pond. These impressive structures feature underwater entrances to discourage predators. Beavers cover them with a fresh layer of mud every Autumn to ensure they are sound for the cold winter months.



A re-sprouting beaver-gnawed stump near the recently abandoned dam. Beavers typically prefer trunks 4-6 inches in diameter for dam construction.

Beavers create dams in existing waterways and wetlands by plugging outlets with sticks and mud. The flooded water bodies that result are rich with aquatic plants that are central to the beaver diet, and also are more optimal for their maneuverability. Beavers are ungainly on land, and will only travel about 200 feet from the pond's edge in search of tree forage—



View north of the wetland beaver pond. When the dam breaks down completely, the rapid lowering of water levels will lead to different plant communities, as opposed to the marshland species seen here.

any farther, and they risk high susceptibility to predation. By raising the height of dams and digging strategic canals, beavers can expand their range of harvestable trees.

Aside from construction material for their dams and lodges, beavers rely on young trees as a source of winter nutrition. They will always preferentially gnaw certain species, such as willows, before moving on to others, like oaks, and later birches. By the time only pines and hemlocks are left, the beavers abandon their ponds to start over somewhere else, typically after only 5-20 years. Over time, the abandoned ponds deteriorate and the forest regenerates around their edges.

Great Mountain Forest contains a number of sites with evidence of beaver activity, which together constitute a patchwork representative of different periods of abandonment. Wampee Pond, in the southern portion of the forest near the intersection of the Number 4 Trail and Old Meekertown Road, is still an active site of beaver habitation. Though the pond was originally dammed by GMF forester Bill Preuss in 1937, the beavers have done their part to maintain its integrity by piling and weaving



The beaver meadow near Chattleton Road. Though long gone from this site, the legacy of beaver activity lives on in the early successional shrub habitat where their pond once lay.



One of the GMF Field Book authors, offering a dramatic beaver-gnawing reenactment. Unlike human teeth, beaver incisors are coated in a hard, iron-rich enamel that prevents chipping and decay (Gordon et al 2015).

small branches in its cracks. Though there are many gnawed stumps around its periphery, enough desirable trees of appropriate size still exist for them to stay where they are for now.

The wetland immediately northwest of Canaan Mountain Road (see map) is now technically part of the Housatonic State Forest, though until recently it belonged to GMF. The beaver pond at its center is a prime example of recent abandonment. The dam at its southern edge is still mostly intact, but is leaking in certain places to join the flow southwards into Wangum Brook. Chewed stumps are abundant, though all are at least several years old, and there is significant regrowth of swamp ash and silky dogwood around its edge. Nonetheless, it is very striking to note the differences in vegetation still regulated by the beaver legacy. In the area north of the pond where water is being held by the dam, tall marsh monocots such as the common cattail (*Typha latifolia*) and common reed (*Phragmites australis*) are the predominate species. South of the pond, where water trickles in slowly, the wetland is a mucky tangle of shrubs and vines such as sweet pepperbush (*Clethra alnifolia*), arrowwood viburnum (*Viburnum recognitum*), multifloral rose (*Rosa multiflora*), wild grape (*Vitis* sp.), and speckled alder (*Alnus incana*), with a variety of ferns and herbs crowding the understory.

Once the dam completely breaks away, water retention returns to pre-beaver levels. The damp ground fills in quickly with shrubs and herbaceous plants. A good example of one of these “beaver meadows” at GMF can be found east of Chattleton Road near Yale Camp (see map). A meandering stream runs through cut sandy banks, no longer swelled to pond-sized proportions. Without further disturbance the site will likely grow back into forest, through in the meantime it serves as beneficial early successional habitat.

By creating this patchwork of ephemeral dams, here at GMF and elsewhere, beavers can dramatically alter the hydrology of an ecosystem. A growing body of evidence demonstrates that this cycle of land use benefits a suite of other plant and animal species by allowing water to be retained for longer periods of time. Their return to the GMF landscape in the past century heralds a new era of beaver-mediated ecosystems.



A series of beaver gnawed beeches near Lost Pond. In many cases, trees are not completely felled, but girdled around the base to encourage new growth.

### Resources

*Lyle, Gordon M., Michael J. Cohen, Keith W. MacRenaris, Jill D. Pasteris, Takele Seda, and Derk Joester (2015) Amorphous intergranular phases control the properties of rodent tooth enamel. Science 347, 746-750*

*Wessels, T. 1997. Reading the Forested Landscape. Countryman Press, Woodstock, VT.*



An area where the abandoned beaver dam is starting to break apart. Without continual maintenance, the sticks become dislodged and flushed downstream.



## LAND USE HISTORY

At GMF past land use in an ecological sense is nothing more than a forest disturbance. Cutting, burning, grazing, plowing, road building all occurred in Great Mountain Forest with one of these on almost every acre. But disturbance is a spectrum; cutting a few trees could be considered a minimal disturbance. Clearing the land, however, then burning it and turning over the soil is a much more substantial form of disturbance where very little of the original ecological community remains.

While most of GMF has been cutover, or settled, only a portion of the landscape has been cleared. During the charcoal and sawmill days, those cutters were selective in the species and sizes that served their needs. Hemlock was typically left behind, until the tannery era. And oak was cut repeatedly for charcoal, but it continuously resprouted. Cutting, then, was and still is, one of the lighter to moderate forms of human disturbance.

Agriculture, as well, can be a light touch, such as grazing a few animals over large acreage. Or it can be landscape altering with clearing, burning, grazing, and plowing. On several sites described here, agriculture, as short lived as it was, allowed a suite of early successional trees and other plants to emerge unlike the composition previously on the site. Stands of old-field white pine, for example, often now grow on these sites. The soil was disturbed and any long-lived ground flora is gone, replaced by ruderal, old field species for at least a couple centuries. It takes hundreds or even a thousand years or more for the full suite of forest organisms to reclaim a completely disturbed site.

In this section you will find nine sites that tell the story of peoples' interaction with the land at Great Mountain Forest over the past 200 years. People of varying means settled this land. Few made it work for more than

a couple generations. Their stories today live on in the stone walls, collapsing cellar holes, clearance cairns, hearths, fireplaces, barbed wire, sawmills, and more. After visiting these nine sites, you should have a reasonable understanding of the intersection of people and forest at Great Mountain. When we view the landscape through both ecological and cultural lenses we find the two lenses inseparable.

The exception is recent forest management. Forest activity since Ted Childs' day is important and interesting enough to warrant its own Forest Management section which follows. This Land Use History section covers settlement up to the Ted Childs era.

## LAND USE HISTORY 1: CHARCOAL HEARTHES

### Summary

This is a general landscape feature that appears dozens if not hundreds of times in GMF. The charcoal hearths, along with coppiced trees, provide a lasting legacy of GMF history. Because charcoal hearths are the most common land use feature in GMF after coppiced trees, it is worth expanding here, from what is otherwise simply a field mark.

### Access

Many hearths along Canaan Mt. Road are visible from the road. See location for several easily accessible sites. Other easy sites occur south of Yale Camp. See maps and locations right.

### Location

*Charcoal Hearths with easy access occur at:*

*Canaan Mt Road area: (see map)*

*East roadside 1: 41°56'59.01"N; 73°16'53.36"W*

*East roadside 2: 41°56'57.73"N; 73°16'53.30"W*

*At Katsura stand: 41°56'55.86"N; 73°17'10.85"W*

*Along road cut: 41°56'57.94"N; 73°17'11.49"W*

*North side of road in Appalachian forest and 2000 cut: 41°56'54.76"N; 73°17'4.38"W*

*In forest with Chestnuts and maidenhair fern: 41°57'0.75"N; 73°17'7.48"W*

*In forest near cliffs: 41°57'2.65"N; 73°17'7.12"W*

*Farther north outlier in forest: 41°57'7.12"N; 73°16'57.40"W*

*South of Yale Camp (see map):*

*Along Chatteleton Road (turn here for Collier's Cliff): 41°56'6.98"N; 73°16'7.35"W*

*At Collier's Cliff: 41°56'7.10"N; 73°16'13.77"W*

*South from above along ridge: 41°56'0.82"N; 73°16'9.31"W*

*Next south: 41°56'0.12"N; 73°16'8.55"W*

*Last south: 41°55'59.33"N; 73°16'7.30"W*

### Description

The estimated hundreds of charcoal hearths found in GMF are a legacy of the region's history, and a demonstration of human-nature

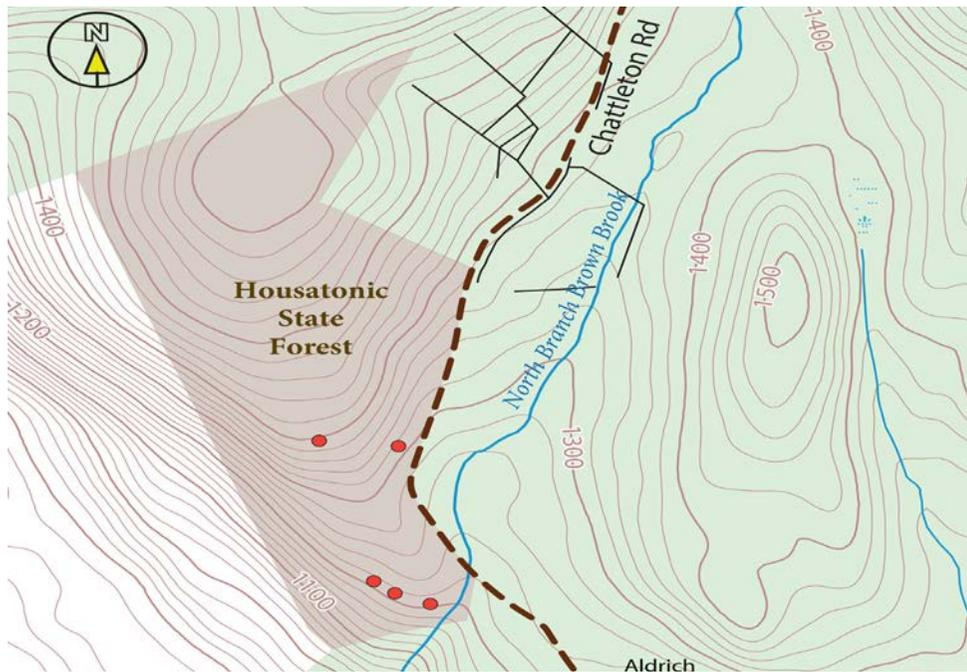

South of Yale Camp area charcoal hearth locations.

relationship. The direct effect of charcoal hearths on the landscape is small (100 hearths amounts to less than 2 acres). However, the indirect effects though the process of making charcoal were significant, altering forest composition and structure for hundreds of years.

### Process

Charcoaling first involved cutting wood into four-foot lengths, called billets. This was typically done in winter when sap quantity was lower. In summer colliers would clear a hearth. Hearths were typically set on gentle slopes where the uphill portion was dug out and filled into the downhill portion. This made a roughly circular flat area approximately 20 feet (6m) to 30 feet (9m) in diameter. Upon this, 30-50 cords of wood, taken from about 3-acres of land, was stacked in the shape of a dome with an open chimney in the middle. Wood thicker than 6-inches in diameter was split. Hardwoods were used almost exclusively and hemlock was rarely used as Connecticut furnaces typically avoided it (Gordon 1996). The stack was covered in leaves and soil to prevent the wood from igniting. Many of the GMF hearths have small pits dug around the edges presumably from soil

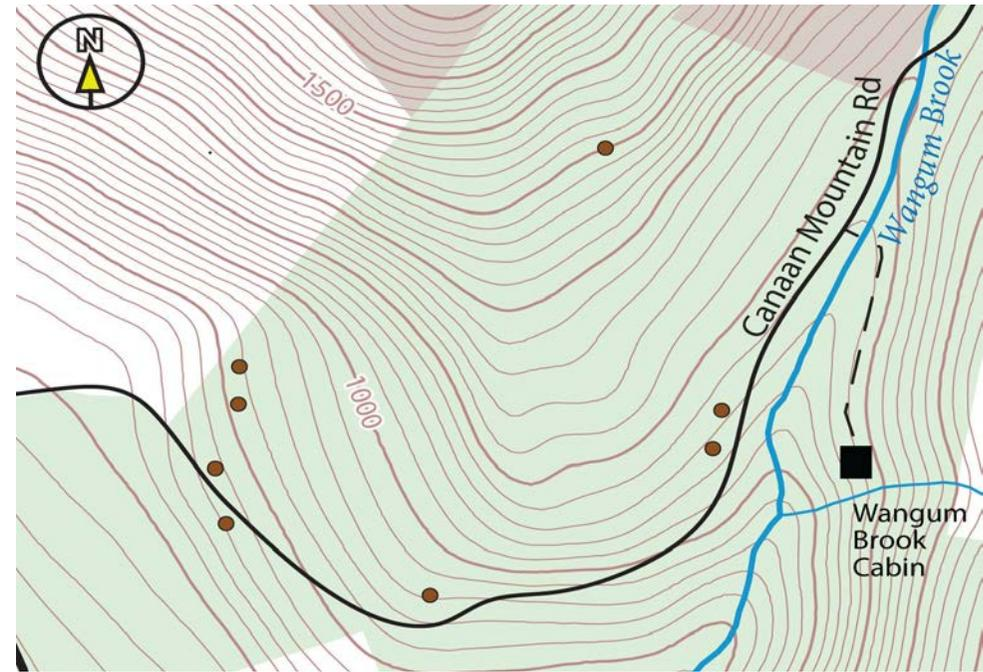

Map of Canaan Mt Road area charcoal hearth locations.



This hearth occurs on the north side of Canaan Mt Road up along the base of the steep slope. It is a large hearth, and though no trees grow on it, there are a number of herbs. Notice how it has been mounded up on the left and cut into the side of a slope. Typical GMF hearth.



This hearth also shows excavation from the slope on the right and mounded up on the left. This hearth has a few white pines growing on it. Often one tree grows on the site from the location of the pole placed in the center of the stack.



This hearth in the rocky soil on a higher slope has stones forming the base of the built-up section (lower left). Though the surrounding forest has grown up (background) the hearth has only herbs and seedlings.

excavation for this purpose. Smoldering water, gasses, and resins out of the wood produced pure carbon charcoal.

Colliers would build three or more hearths close together and then construct a small hut nearby from where they could watch over the hearths. If the pile began igniting they would have to add more leaves and soil, or douse it with water. Once in a while the fire would get away and scorch the slash and burn the cutover forest.

Typically stems down to 3-inches (8 cm) were used. Clear cutting was the most common practice. The controlled smoldering of wood from forest trees produced a form of crystallized carbon that was ideal for iron furnaces. Smoldering would take approximately 2-weeks. When the charcoal was unearthed, it was extinguished or cooled with water, bagged into bushels, and loaded for transport to the furnace.

One-acre of land yielded 20-cords of wood. One cord of wood made 33-bushels of charcoal, or 660-bushels of charcoal per acre (~1500-bushels per hearth). It took 250-bushels of charcoal to make a ton of iron, or 1-acre of woods to yield 2.4 tons of iron. (J. Bronson personal communication).

### Legacy

Studies by Mikan and Abrams (1995; 1996) and Young et al. (1996) suggest numerous soil chemistry changes from the charcoal process. The legacy is evident in the slow and poor recruitment of vegetation on hearth sites. Specifically, Mikan and Abrams (1996) show hearth sites have elevated pH, cation exchange capacity, base saturation, and exchangeable Ca, Mg, and K relative to surrounding soils. Greenhouse experiments of hearth soils show reduced growth and vigor compared to surrounding soils.

Interestingly, at least two sites in GMF show remarkable diversity and richness growing on the hearth site. On a site near the Meekertown Sawmill (this section) plants include wake robin trillium, hog peanut, jack in the pulpit, Solomon's seal, among others. These plants occur only on the hearth site in a hemlock forest with otherwise little herbaceous vegetation. What happened to this soil on the hearth to allow not just richness, but richness in a low-diversity forest? In the Appalachian Forest (see Natural Communities) a hearth lies covered in maidenhair fern and small chestnut trees. The chestnut sprouts must postdate the last burning around 1900. There is



This is the "Rich Hearth" found near the confluence of Brown Brook and the North Branch of Brown Brook. In the background notice the complete lack of herbaceous growth in the hemlock forest. However, the hearth is lush with flowers atypical for both the hearth and the forest.

no evidence of dead stems from chestnut blight and dieback. It is possible that this tree arose from a seed recently.

Charcoaling altered forest composition in favor of vigorous coppice resprouts such as oak. Coppice red oak is abundant throughout GMF especially on higher slopes in communities now dominated by oak and which also contain many hearths.

### Importance

The Charcoaling era was noteworthy in GMF history. The amount of wood cut and the shift in forest's composition, suggests this was a significant disturbance in GMF. Understanding the charcoal era is critical to understating the contemporary forest as well as the human history and conservation efforts that followed.

### Research Suggestions

What species of wood was burned in the hearths? (Observable charcoal fragments available at sites should reveal the species of tree burned.)

- What is the process of succession on charcoal hearths?
- What soil chemical or physical changes occur on charcoal hearths?
- Why are two hearths covered in flowers when no other (known) hearth is, nor the surrounding forest?
- How did charcoaling alter forest composition in GMF? Which species were selected for? Which species regrew? Did vigorous coppice sprout species (oaks) come to dominate?
- What stand ages are found around charcoal hearths? Do these match the dates of cutting indicated by coppiced oaks?

### Resources

- Winer, H. 1955. History of Great Mountain Forest. Dissertation, Yale University.*
- Mikan, C., and M. Abrams. 1996. Mechanisms inhibiting the forest development of historic charcoal hearths in southeast Penn. Canadian Journal Forest Research. 26: 1893-1898.*
- Mikan, C. and M. Abrams. 1993. Altered forest composition and soil properties of historic charcoal hearths in southeast Penn. Canadian Journal of Forest Research 25: 687-696.*
- Young, M., et al. 1996. Vegetative and edaphic characteristics on relic charcoal hearths in the Appalachian Mountains. Vegetatio 125: 43-50.*
- Rand, C. 1968. The Changing Landscape: Salisbury Connecticut. Oxford Press.*
- Gordon, Robert. 1996. American Iron: 1607-1900. The John Hopkins University Press.*

## LAND USE HISTORY 2: S. DEAN HOMESTEAD (MEEKERTOWN)

### Summary

This small settlement site located in southern GMF provides a glimpse at the marginal conditions upon which farming was attempted, and leaves questions about intention from several landscape legacies. Little is known of the settlers of this property. Both groundwork and historical research present opportunities for discovery.

### Access

The site is 1.67 miles walk south on Chatleton Road from Yale Camp. Or, it is 0.66 miles walk west on Meekertown Road from Trail #4 at Wampee Pond.

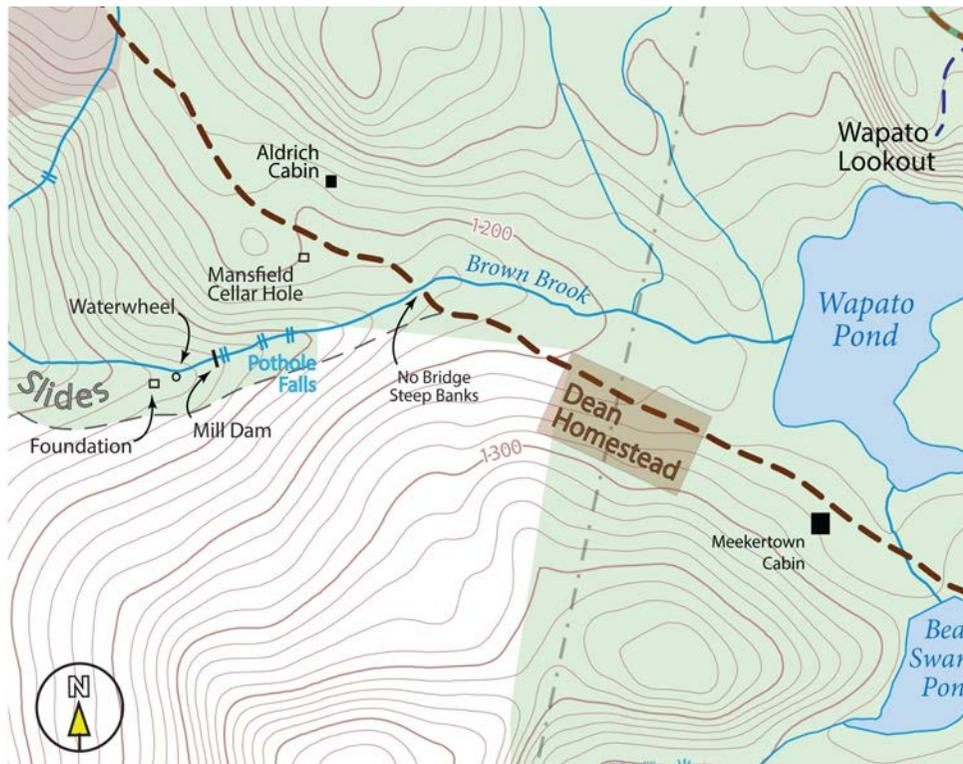

Location of Dean homestead at Meekertown. Evidence of the settlement is scattered throughout the area, and perhaps beyond. The Norfolk-Canaan Town Line is the dashed line running north-south.

### Location

*Site occurs on the south side of the road/trail: 41°55'44.25" N; 73°15'35.08" W*

### Near-by or Comparative Sites

The site serves as an excellent comparison to other settlement sites. It compares nicely with other small sites to see how the smallest farms got by. These include the Trail #4 Pioneer cabin, and the Mansfield site.

### Description

On the south side of Meekertown Road at this site a faint trail rises up the slope. It quickly fades in an area with several clearance cairns. Settlers created these stone heaps by ridding the ground of stone to increase pasture production. This site does not appear to have had crops (though a small garden likely occurred somewhere); the area would have been pasture for animals. The extent of the area pastured is unclear; it may have remained close to the settlement, or continued upslope some distance. If it had continued up-slope, the impact on the land was minimal. An acre or two of land shows sign of intensive land-use (smooth ground, indicator plants).

A stonewall runs along Meekertown Road to the west. And another wall runs south (uphill) away from the road for about 100 yards. This fence would have hemmed in the farm on its western edge. This stone fence appears to occur on a property line slightly west of the town line that may have itself been a survey error for the town line. The western line serves as the property line for GMF today. Inside this wall (to the east) are the telltale signs of pasture: smooth ground, young even-aged trees, dense Canada May-flower, and about a dozen clearance cairns.

Subtle remains of a foundation occur on a small rise near the stonewall, just beyond the smooth ground. The rise has been flattened, and a few stones serving as piers likely supported a structure. There is no cellar hole, so maybe this was not a year-round settlement. The site would have provided nice access to the pasture, and also a perch above the road.

The site is located on Meekertown Road and could have served products to the many colliers and sawyers working these woods. It appears to have been small production, nonetheless, and/or perhaps only lasted for short duration.



Location of the Dean homestead on the 1853 (Fagan) maps of Canaan and Norfolk, Conn. The maps are joined in the center where the dean property occurs on both maps as it lies on the town line. Chattleton Road enters from the upper left, Meekertown Road from the lower left.



Three clearance cairns at the Dean site. There are a dozen or more clearance cairns (aka: stone heaps) at this site. These indicate clearing of stones from fields. Small stones were simply placed on a large unmovable boulder.



The stonewall running north-south along the west property line at the Dean site. The wall is short (~100-meters) and ends abruptly where a wooden fence would continue. Large stones indicate it was a fence rather than clearing frost-derived stones (small) from an agricultural field.

### Importance

This site is small and compared to other settlement sites is probably of minor importance. Nevertheless, it serves as a good example of yet another way people were making a living in Meekertown and GMF in general.

### Research Ideas

Mapping cairns, walls, and house site etc.

Succession on old pastures

Historical research into ownership and/or tenants (who lived here?)

### Resources

Wessels, T. 1997. *Reading the Forested Landscape*. Countryman Press, Woodstock, VT.

## LAND USE HISTORY 3: SOUTHWEST STONE WALLS

### Summary

This site contains a system of stonewalls amounting to 1.25 miles on GMF property and an unknown amount of contiguous wall south of GMF lands. Classic examples of former pasture, as well as sections of wall occur in hardwood forest and old field pine.

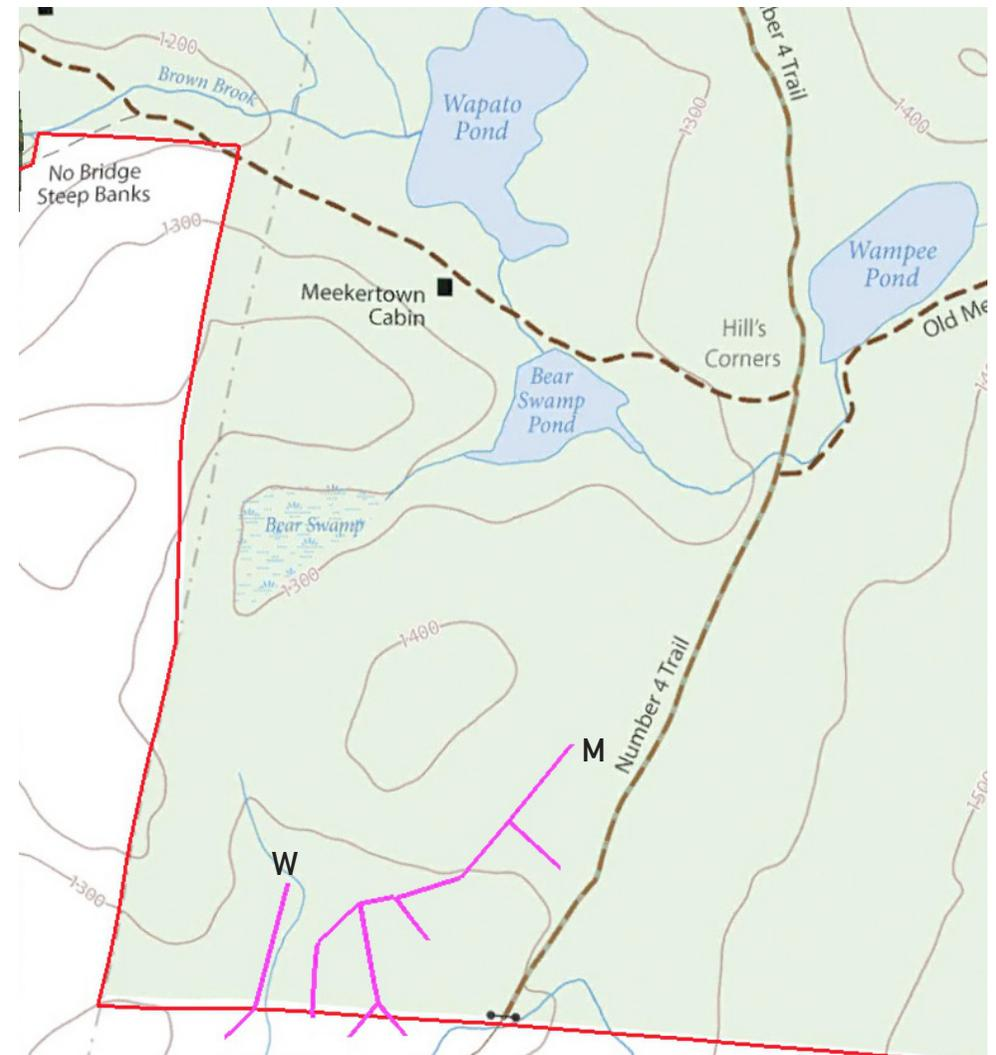

Location of Southwest Stonewalls in the southern reach of GMF. Walls are shown in pink. M indicates moose enclosure site and W indicates West Wall for coordinates reference.



A length of well-preserved wall from the southern stonewall maze. Over a mile of wall, much of it well preserved, occurs here. Notice the distinct communities on either side of the wall. The near side contains sparse ground-flora while the far side contains a dense rich layer. The differences will be accounted for by the land-use practices occurring on the opposite sides of the fence. Closer examination will reveal the exact practices.

The area around the stone wall maze contains abundant old-field white pine including many weevil-damaged pines such as these. When pine establishes in dense, full sun areas like old fields, weevils proliferate and damage the trees' leaders. This creates multi-trunked trees. Pines do not coppice or resprout like oaks, maples, etc.

### Access

Best access is from the southern end of the Number 4 Trail. Access via the Moose Exclosure site (see forest management sites) brings one to the northeastern terminus of the wall system.

### Location

The walls occur in the far southwest corner of GMF property, and run off the southern property boundary. Coordinates for two locations given below:

#### *Western Wall:*

41°54'57.77"N; 73°15'34.33"W

#### *Moose Exclosures:*

41°55'12.69"N; 73°15'10.84"W

### Near-by or Comparative Sites

Adjacent to this wall-maze is the moose exclosure. A rich talus community occurs in the ravine to the northwest of the Western Wall (see map). The Dorman home-site on Chatteleton Road also contains abundant stonewalls.

### Description

This is an excellent but sprawling site for people interested in pasture abandonment, old-field succession, and stonewalls. A dozen wall segments link up to create a 1.25 mile long wall complex, with contiguous walls continuing on private lands to the south. The walls appear to all be pasture fences, indicated by the large stones. (Walls made from stones removed from crop fields would have small stones.)

There are clear signs of old field communities. These include stands of old field white pine, some weevil-damaged white pines, extensive patches of smooth ground, dense communities of Canada May-flower, and

clear community delineation on opposing sides of walls. Additional early successional species are found (black cherry, red maple, etc.).

Many of the pines show damage from the white pine weevil (*Pissodes strobe*). The weevil kills the terminal leader of vigorous white pines growing in the open. Once the leader is damaged and dies, branches from the upper-most whorl shoot up.

It is unclear when this area was pastured, for how long, and when it was abandoned. The photo right shows the site in 1934 and also in 2012. Even in 1934 there was considerable tree cover suggesting that abandonment occurred at least 50 years before that. The peak of agricultural abandonment in New England was the late 1800s (beginning ~1860 and leveling out by ~1950). By coring pines, one should be able to attain an accurate date of abandonment.

### Research Ideas

Date of pasture abandonment? Degree of clearing (percent cover?)  
Effect of stonewalls on wildlife in second-growth forests: corridors or impoundments?

### Resources

Allport, S. 2012. *Sermons in Stone: The Stone Walls of New England and New York*. Countryman Press.

Thorson, R. 2004. *Stone by Stone: The magnificent history of New England's Stone walls*. Walker and Co.

Foster, D. G. Motzkin, and B. Slater. 1998. *Land-use history as long-term broad-scale disturbance: regional forest dynamics in central New England*. *Ecosystems* 1: 96-119.

Wessels, T. 2010. *Forest Forensics: A Field Guide to Reading the Forested Landscape*. Countryman Press.

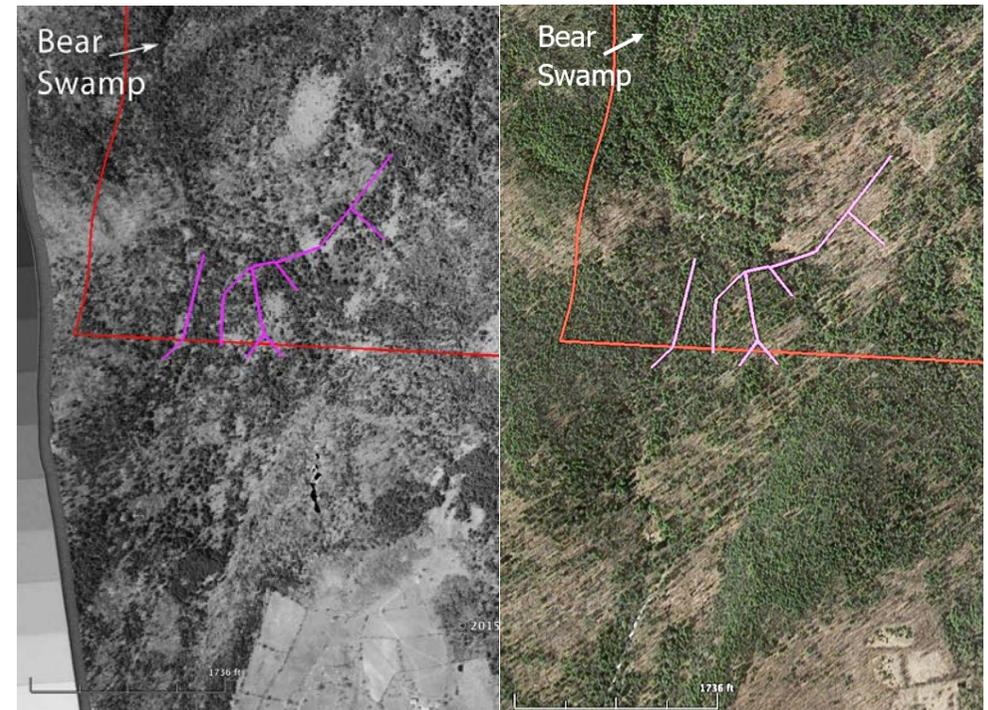

Southern Stone wall Maze and adjacent property south of GMF taken 1934 (left) and 2012 (right). Stone walls in pink and GMF southern border in red. The walls amount to 1.25 miles. It appears the old pastures around the walls were accessed via properties to the south as they occur in the same watershed. Note the change in field cover at the bottom

## LAND USE HISTORY 4: NORFOLK DOWNS GOLF COURSE

### Summary

The abandoned Norfolk Downs golf course is an interesting slice of land-use history showing that even contemporary land-uses can fail and revert back to forest. Here, a golf course purchased by Ted Childs in the 1940s, naturally reforested (portions were put in plantation). The white pine dominated forest provides a nice laboratory growing on glacially derived deposits.

### Access

Best access is via “The Shelter” on Golf Drive. Inquire with GMF.

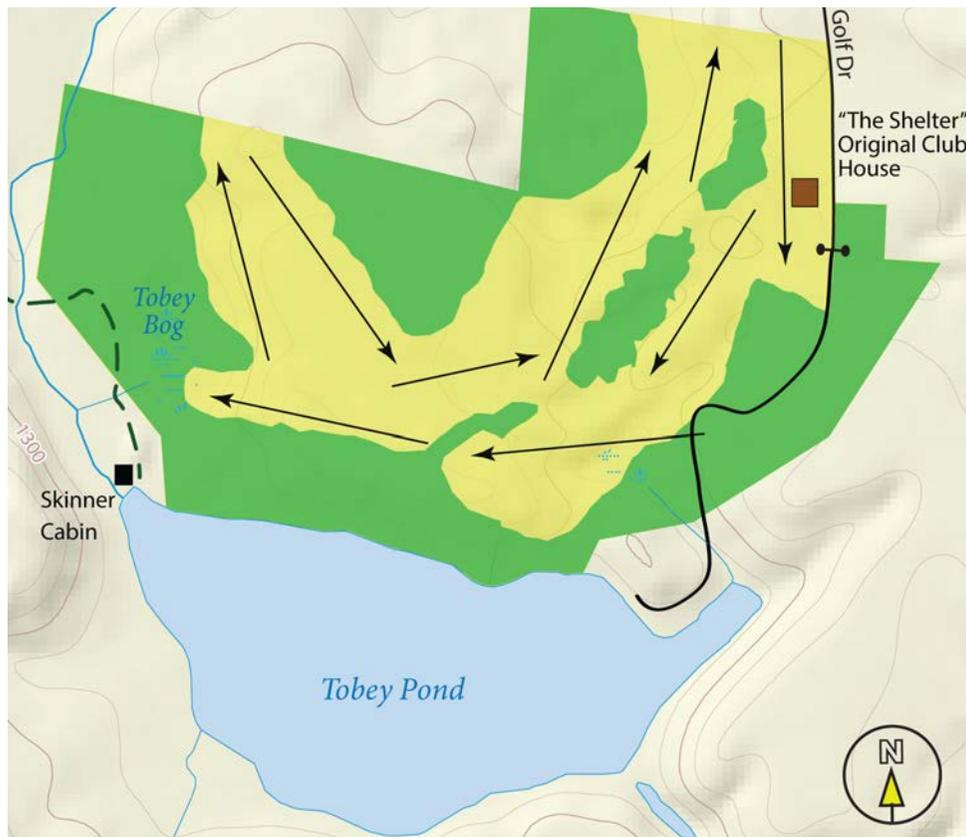

Norfolk Downs golf course as played in the 1940s. The site is forested now having grown since Childs purchased the property.

### Location

The old golf course occurs south of the existing Norfolk Country Club and north of Tobey Pond. The property is GMF owned but inquire to gain access.

#### *Legacy Cherries:*

41°58'52.71"N; 73°13'20.64"W

#### *Young Pines:*

41°58'51.37"N; 73°12'59.52"W

#### *Glacial Deposits in white pine:*

41°58'43.14"N; 73°13'5.77"W

### Near-by or Comparative Sites

This site contains glacially deposited sediments and topography of Glacial Lake Norfolk described in the geology section. To the west is Tobey Bog (see Natural Communities) and the North-40 old growth hemlocks (see Natural Communities).

### Description

This interesting site contains a 9-hole golf course that has, over about 60 years, reverted back to young forest. Ted Childs bought the property in the 1940s and allowed it to revert naturally to forest. A few small plantations were established, but the majority of the property has reverted to old field white pine. The ground, although it is dramatically topographic due to glacial deposits, is remarkably smooth as a golf course would be. To the observer, a pasture would come to mind, which the land likely was prior to golf. Perhaps using the maps shown here one could seek out the greens and tees. We found the undulating glacial deposits masking any sense of fairways or greens.

Nonetheless, this is a fascinating area with several successional stands ranging from about 15 years, to 25 years, and over 50 years. A few legacy black cherry and hemlock trees were also found (see location for coordinates). Invasive plants, mainly barberry, are scattered but not prolific.

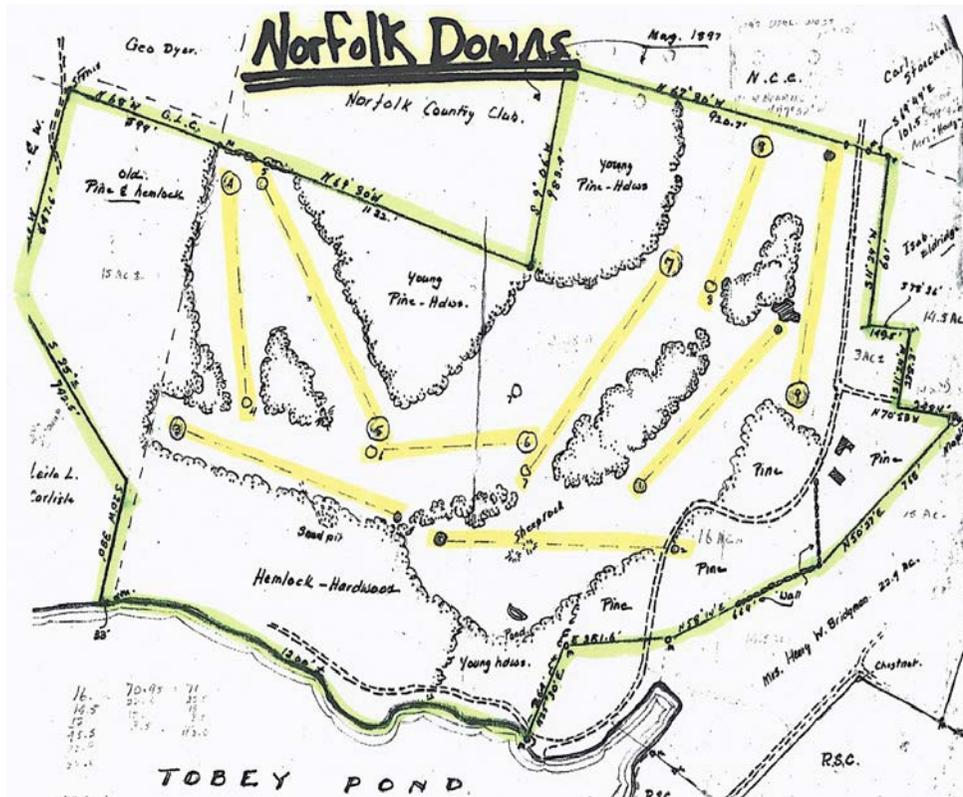

Map of the Norfolk Downs golf course by D.G. Bush dated June 2, 1945 showing forest types in the wooded areas between fairways. These could be groundtruthed for relevance. (Map courtesy of Great Mountain Forest.)

### Importance

Another example of old field pine succession. It could be interesting to see if the greens, tees, and traps contain unusual communities.

### Research

Colonization of greens, and traps.

Old field pine succession and wildlife

To see if the distribution of current species shows dispersal from the various source populations around the edges (hemlock to the west, cherry and hardwoods to the north, etc.).



Typical old-field white pine community in the abandoned Norfolk Downs golf course at GMF. Some pines, as expected, are weevil damaged. Trees appear to be about 60 years old. Coring should confirm actual date of abandonment.



A younger stand of paper birch and yellow birch on the golf course. Dense stands such as this occur mainly on the east side of the parcel. Areas within these are dominated by white pine.

## LAND USE HISTORY 5: MANSFIELD SITE

### Summary

According to the 1853 (L. Fagan) map the site was owned or inhabited by E. Mansfield. Since Elisha Mansfield was a land trader of sorts, it is unclear if he and/or his family actually lived there, or simply owned it, or something else. It may have been the elder Mansfield's homestead, and perhaps simply owned by the younger Mansfield, uninhabited or rented in 1853. Nonetheless, the site contains an excellent cellar hole, a series of poorly constructed stonewalls and cairns, and several legacy trees.

### Access

Access to this site is from Chatleton Road, 1.45 miles south of Yale Camp. Alternatively, one could enter from the Number 4 Trail and walk 0.8 miles west on Old Meekertown and Chatleton Roads. The site is listed as Point 7 on the GMF Trail Map.

### Location

*Coordinates to cellar hole:*

41°55'50.58"N; 73°15'52.64"W

### Near-by or Comparative Sites

The Dean homestead (Land Use section) occurs 0.3 miles east on the Meekertown Road. Sawmill remains (this section) occur nearby on Brown Brook. Stonewalls and hearths are scattered throughout.

### Description

This site contains one of the best preserved cellar holes in GMF along with a series of small, incomplete stonewalls, and clearance cairns. The Mansfield homestead provides yet another example of the ways people were living and making it work in Meekertown.

The 1853 map identifies the site as belonging to Elisha Mansfield. Winer (1995) makes few references to the site, instead noting the various land purchases by the Mansfields' and their sawmill located slightly southwest on Brown Brook. Winer (1955) also discusses in some detail the Mansfield burn – a fire that occurred on a property owned by Mansfield in 1851. See Winer (1955 p.190) for more details on the Mansfield Burn.

According to Winer (1955) Elisha Mansfield built a cabin in 1795 on

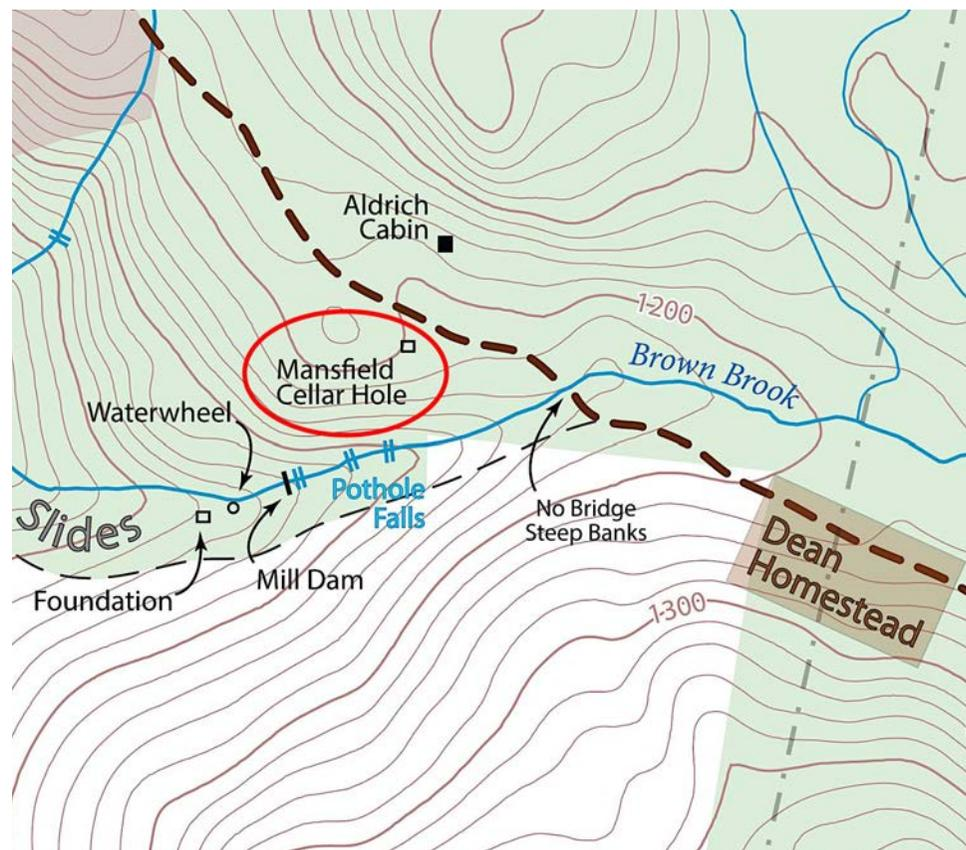

Location of the Mansfield Cellar Hole in Meekertown.

the site of today's Yale Camp. Sometime after 1806, when he and Dorman bought land, on what was then called Meekertown Brook (aka Rocky Brook) at the town line, he built a sawmill. Today this is known as Brown Brook (presumably named for Meeker's wife with last name of Brown). He also cleared and graded Chatleton Road from today's Yale Camp to the Meekertown Road. In 1829 Mansfield sold the mill to his son Elisha D. Mansfield. In 1831 Lyman Howe purchased the mill and operated it until 1874. Thus we don't know if it was Mansfield the elder or younger who owned the homestead property in 1853, though chronologically it seems it was the younger.

The cellar hole is one of the larger cellars found in GMF though still amounts to only one or two rooms. With its topographic setting (see location map above) the inhabitants would have had vast southwest views from the hilltop just a few dozen yards from the house. The scant amount



1853 map of Canaan, CT showing the area of Meekertown including the Mansfield home site (center) and sawmill.



Mansfield Cellar Hole along Chattleton Road near Brown Brook. This is one of the better-preserved cellar holes in GMF. With this are an array of stone walls, clearance cairns, and a couple legacy trees.

of stonewall present is not surprising; they would have used much wood fencing as long as wood was available on site. Stone was used only to get it out of the fields (or roads), and as fencing when wood became sparse. So at this site the stonewall (fence) looks pathetic, which it was, because wood and brush would have covered it making a real fence.

### Importance

This is one of the best-preserved cellar holes in GMF (and should be maintained as such mainly by keeping the trees away). The site provides another example of how people were making a living in challenging terrain.

### Research Ideas

Additional work mapping the site and completing a thorough botanical inventory in order to determine the layout and extent of the original farm. Historical research on inhabitants, landowners, etc.

### Resources

Winer, 1955. *History of Great Mountain Forest. Yale University Dissertation.*

Fagan, K. 1853. *Map of Canaan, CT.*

## LAND USE HISTORY 6: DORMAN FARM

### Summary

This is an outstanding site that inspires contemplation in a forest filled with stonework, centuries-old sugar maples, and young stands of trees in abandoned pastures. Approximately 1.1 miles of stonewall occurs in an area of under 30-acres. Complete with a barn foundation, an intact cellar hole, abandoned crop fields, a stream, and dozens of sugar maple and black cherry legacy trees, this outstanding site is an easy walk from Yale Camp. We have expanded the site relative to others because of its value, to include more information, photos, maps, including a detailed map of most site features.

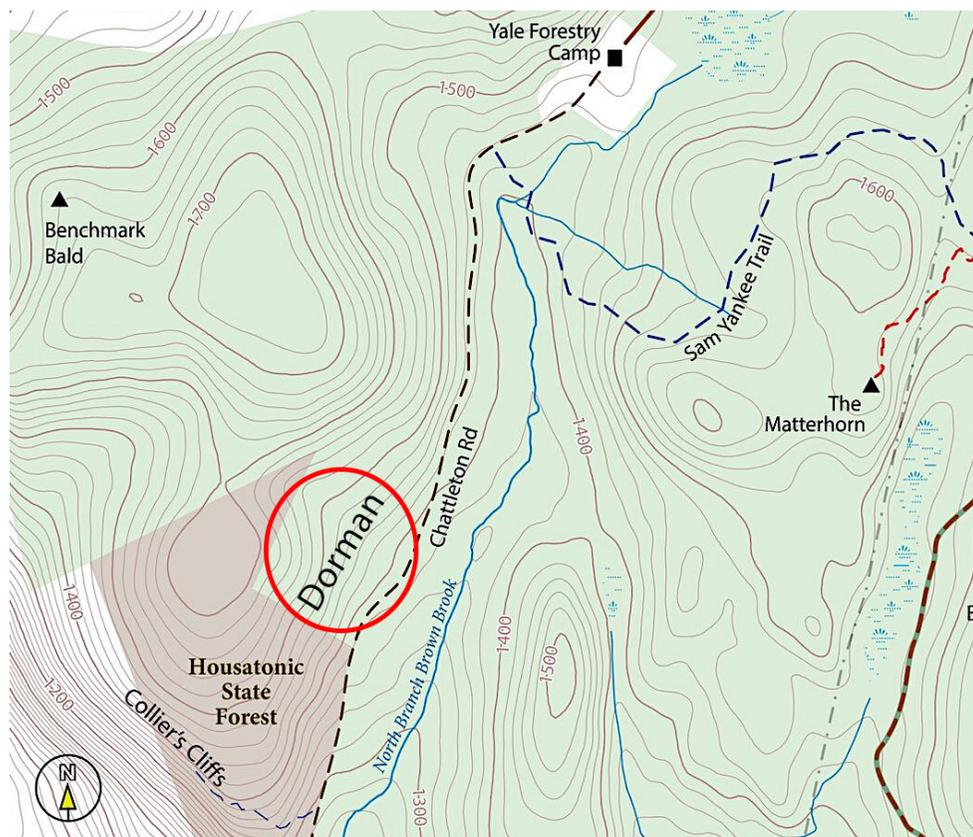

Map of Dorman Farm location.

### Access

The site is accessed via 0.6 mile walk south of Yale Camp on the Chattleton Road. After passing a wet area (with phragmites), large sugar maples and stone walls mark the site.

### Location

Site entrance coordinates: 41°56'22.47"N; 73°15'59.63"W

Additional coordinates for particular places within the site are referenced in the text and map.

### Near-by or Comparative Sites

A burned-over stunted oak woodland also occurs near the summit of the hill above the site. A beaver meadow occurs slightly upstream on North Branch Brown Brook from the site. Two forest management sites occur on the Chattleton Road between this site and Yale Camp.

### Description

#### *General Background and History*

The Dorman site – so-called because it is listed as such on the 1853 map of Canaan, Connecticut – is one of GMF's gems. In a compact area of ~30-acres, one can explore the remains of a life strategy that flourished in New England for a brief century. Today, like the remains of great civilizations the world over, this site lies reclaimed by forest, leaving the contemporary explorer to imagine, study, and search for answers of who they were, how they lived, and what they left behind.

The 1853 map shown here indicates this property along Chattleton Road as owned or resided by C. Dorman. Winer (1955) references Chauncey Dorman, which online records indicate was born in Litchfield County in 1777. It is unclear when Dorman acquired the property or when he settled it. But likely this occurred not before the early 1800s.

Winer (1955) mentions Dorman sparsely and he does not definitively describe this homestead. He notes Dorman and Elisha Mansfield bought the land that would become the sawmill (see 1853 map) in 1806 (p. 171). He further notes (p. 195) that the Dorman and Mansfield families "were associated in a number of ventures." The land south of Mansfield's in 1851 belonged to Dorman. This is today Housatonic State Forest land immediately west of the Dorman site and GMF more generally. Writing about the Mansfield Burn, Winer (1955) states: "as the fire may

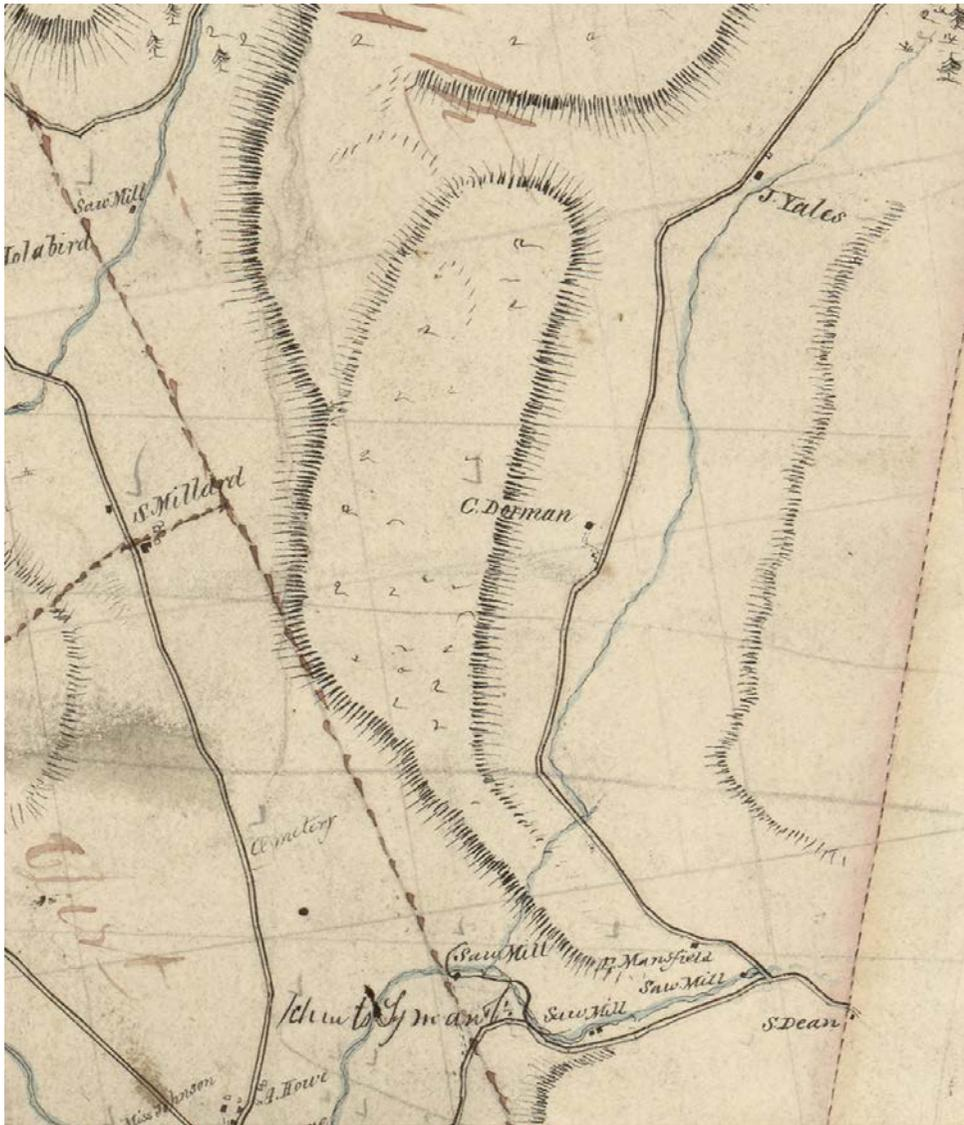

1853 Map showing the C. Dorman property in center. The J. Yales property to the north is the site of Yale Camp (no relation) while E. Mansfield and S. Dean farms occur farther south in the heart of Meekertown.

have started on Dorman's land, one may speculate on the possibility that enough ill will had arisen to breed a claim or suit for damages" (p. 195). These are the only references to Dorman in Winer's dissertation.

To describe the site we will take it element by element, providing coordinates, photos, and referencing a detailed map that follows at the end of this section.

### *Stonework and other farm improvements*

Today the most obvious remains of the farm are the stonework and the sugar maples. The stonework represents an often-underappreciated amount of work. With stones at hand, two men could build 10 to 20 feet of stone wall per day (Alport, 2012; Thorson, 2004). At this rate, the ~1-mile of wall at the Dorman site would have taken two men about 365-days. This was only after they had collected and staged all the stones.

The maps on the next page outline in purple all the stone walls found at the Dorman site. You will see several are comprised of small sections. These gaps would have been filled with wood rails or gates. Larger spans in the north and west lacking wall would have had wood fences initially and later barbed wire after its introduction in the 1870s. Barbed wire is found in the northern sections today (see large map). Other than those sections, we did not find additional barbed wire on this site.

A New England stone wall is rarely taller than thigh-high, though occasionally some reach waist high. It's believed this is a result of ergonomics; lifting stones above the thigh is challenging (Thorson, 2004). To properly pen animals in, the wall would have a rail or rails along the top.

Looking at the size of the stones and the construction we can interpret the purpose of a wall. A well-stacked wall with large stones built was a fence for keeping animals in, or out, of a field. It was as important to for an owner to keep their animals in an enclosure. And it was important for a crop grower to keep animals out of their fields. Stone-fence regulation was serious business in early New England (Wessels, 1997).

A wall comprised of many small stones indicates an agricultural wall, or in other words, stones moved simply to get them out of a field. Freeze-thaw activity, animals, and soil erosion in plowed or overgrazed fields, all expose stones. In a crop field these are always removed so the stones do not damage the plow. In pastures, too, stones are often removed because forage does not grow under rocks and the removal of rocks increases the amount of forage area. Often these fieldstones are heaped or dumped rather than properly stacked, as in a fence (see photos).

Often in pastures or crop-fields stones will be picked up and placed on larger rocks. This could be to simply expose more ground to sun to promote forage, or to clear a crop field. If there are large, unmovable rocks in a field the small stones may simply be placed atop the large ones. These stacks are called clearance cairns, or sometimes stone dumps (see photos on page 142). Little has been written about clearance cairns in New England.

The last stone features at the Dorman site are the cellar hole

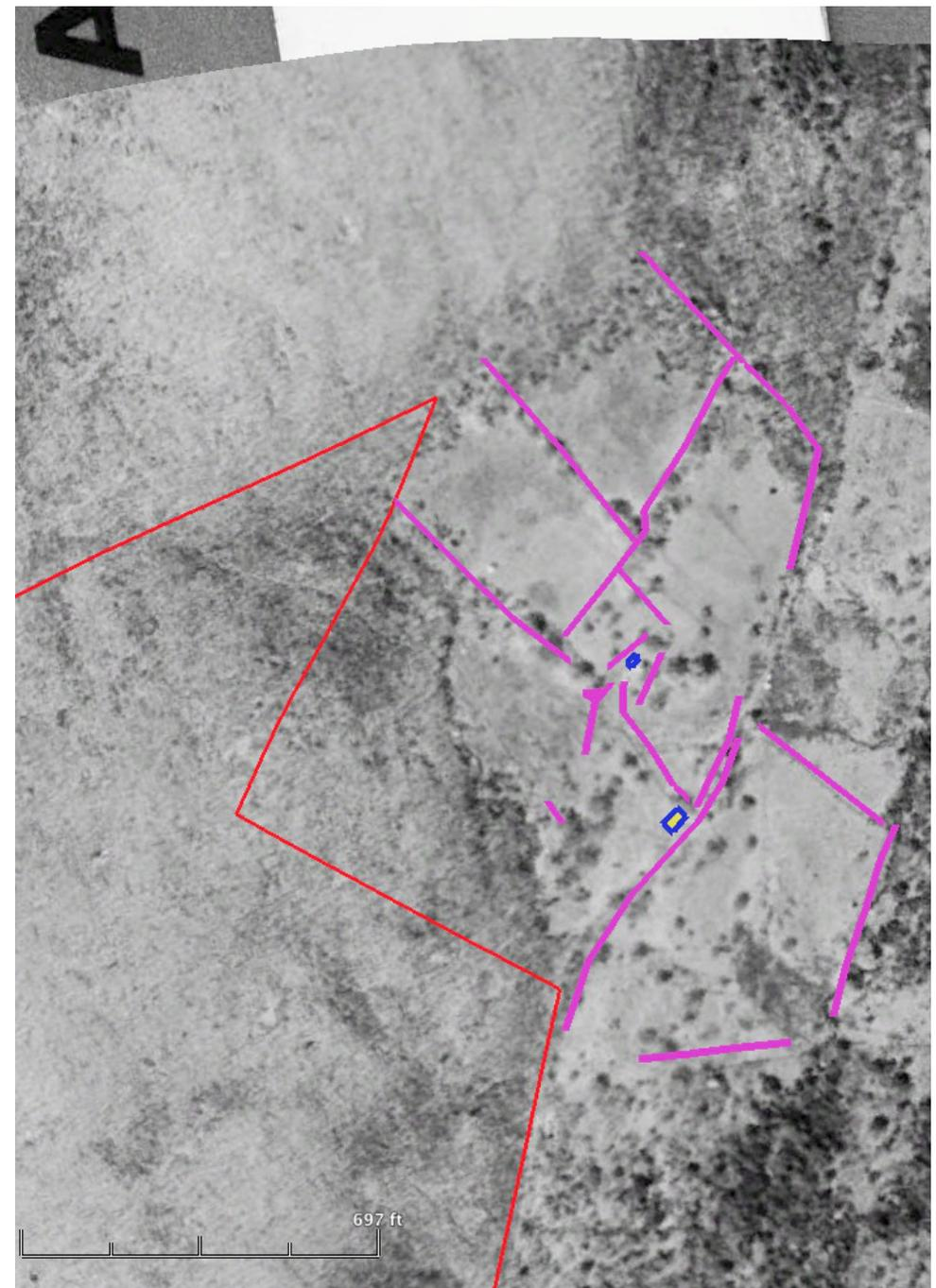
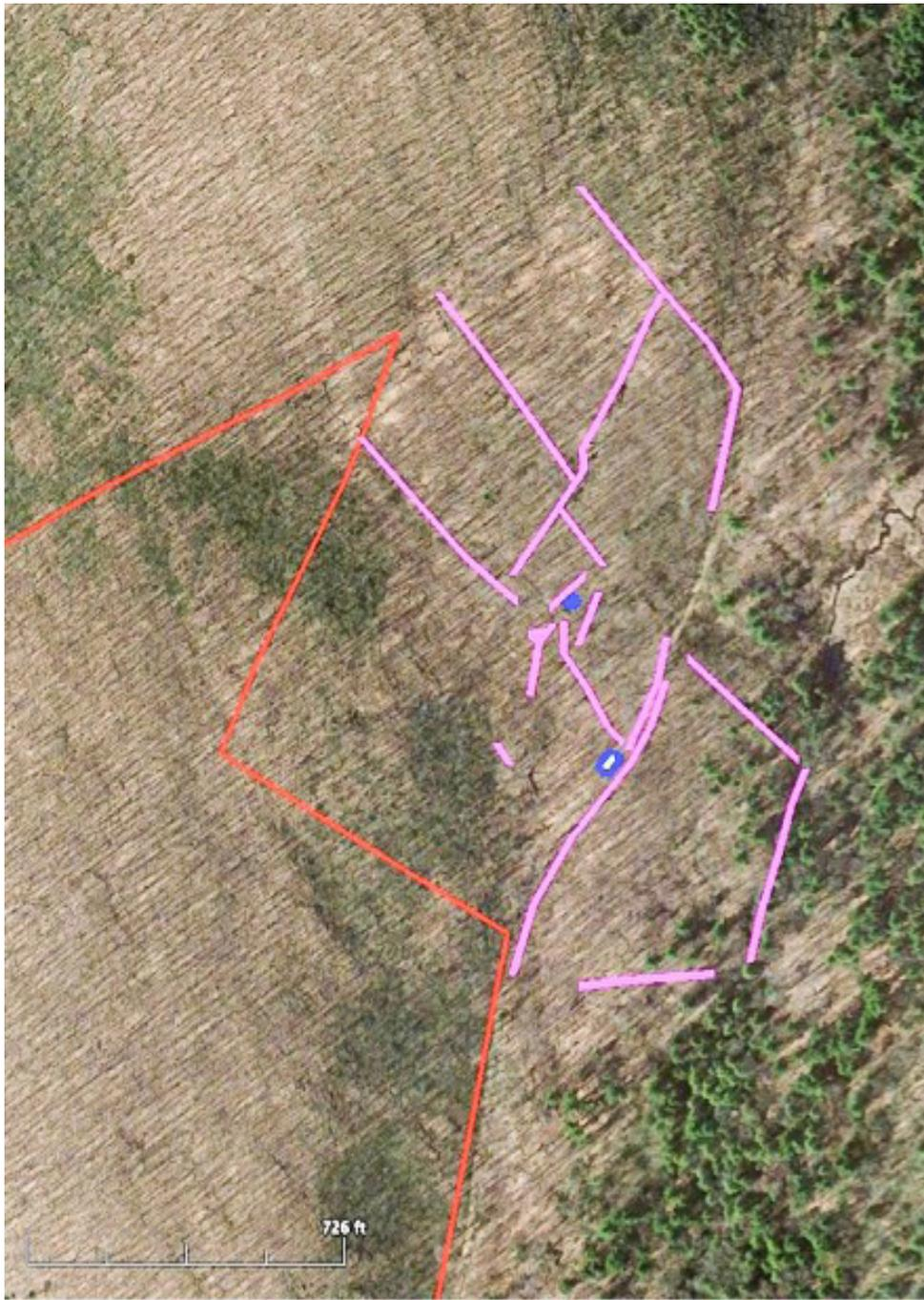

Dorman Farm from 2012 (left) and 1934 (right). Red line on left is GMF property boundary. Pink lines are stone walls identified on the ground and marked with GPS. There is over 1-mile of wall. The small blue rectangles locate the house and barn. Many of the pasture trees in the 1934 image are still alive. Note the patches of mountain laurel that occur in center-left of both images (dark areas). Conifer distribution is also similar despite being nearly 80-years apart.

and barn foundation. The site contains one of the larger and better-preserved cellar holes found in GMF. One wall has collapsed. The house foundation contains a chimney suggesting it was built before 1830 when woodstoves and stovepipe came into use. The barn foundation lies along Chattleton Road at the entrance to the farm. The rectangular structure can be discerned with two steps in the front, foundation stones around the perimeter, and stone footings for center posts (see photos right).

On the west side of the farm, on the edge of the forest (identified by change in community and old edge trees) is a charcoal hearth. It is a typical hearth, and charcoal fragments are evident on the edges. While the surrounding forest contains ferns, and other woody vegetation, the hearth contains mainly grass. Charcoaling changes the soils chemistry such as to prevent plant growth. See the hearth section (Land Use 1). Charcoal was typically not a family operation, but a skilled trade. We can only speculate on the presence of the hearth on the farm site.

It is also important to point out the most widespread and often overlooked field mark for unraveling this site. All the pastures and formerly cleared areas have smooth ground. Unlike the adjacent forest, which, despite almost two centuries of disturbance, has undulating lumpy-bumpy ground, all the pastures and formerly cleared areas have smooth ground. This is an indicator and field mark for identifying formerly cleared areas.

### *Trees and Vegetation*

With the stone walls, the many large old sugar maples comprise the other dominant landscape feature on the Dorman site. Dozens of trees, up to 48-inches in diameter, occur in and among stone walls, near the cellar hole, and along Chattleton Road. The maples are identifiable in the 1934 imagery, and based on bark characteristics they are estimated to be 200-years old. Some trees may be nearer to 300-years. Several large black cherry trees also occur in and among the stone walls. Cherry, as an early successional sun-loving tree probably sprouted up in the walls. Dorman, or whoever the first settler on the site was, likely left many of the sugar maples uncut from the original pre-settlement forest. The trees would have provided sugar as well as shade for cows. Some may have sprouted up in the walls and could now be around 200 years old.

Today the legacy of sugar and shade lies with wildlife. Unlike the small, young trees taking over the old pastures, these old trees provide important forests structural features otherwise not found. Cavities, large hollows, rugose and decorticating bark, form only on old trees. These

features are important to birds and mammals as well as invertebrates upon which the larger animals prey. See Gaige, (2009) for more on wildlife use of legacy trees. See photos for examples of the sugar maples.

Another small group of trees with a story to tell occurs on the western edge of the farm area. In this area stand several edge-trees. The white oaks have branches on the lower (downhill) side of the tree while the uphill side contains no branches. In Dorman's days, these trees backed up to the forest, while the sides with the spreading branches faced the open pasture. The sun exposure allowed the trees to branch out, and spread into the open. See photos for image and coordinates.

Filling in the pasture matrix today are young, early successional trees. On the west side of Chattleton Road, in the main part of the farm, sugar maple dominates (especially lower on the slope) with ash, black cherry, some paper birch. There is surprisingly little oak regenerating in these old pastures, despite the fact that oak dominated the surrounding forest. Perhaps they were not of acorn-producing age when the pastures were abandoned in the 1940s.

On the east side of Chattleton Road, downhill from the main farm, the old fields are dominated by white pine mixed with other species. These pines appear to be 60 years old but they could be cored for accurate aging.

Japanese barberry dominates some areas east of the cellar hole and is a typical invader in old pastures. Often the species was planted decades ago for promoting turkey habitat when turkey was a focal species for conservation and reintroduction. Unfortunately, the people administering those policies did not anticipate the problems we see today from barberry infestation. It is the dominant exotic invasive plant in GMF. No Japanese barberry was planted in GMF for turkeys, though it was distributed to adjacent land owners.

### **Map**

A detailed map of the site is provided at the end of this section. The intention for this is to help groups with limited amounts of time see the layout and be able to visit the features. However, groups with longer amounts of time may wish to engage students by having them map the site (a challenging task!) and checking their work. Or a group may wish to use this map as a starting point to discussion and discovery.



The cellar hole at the Dorman property. The cellar is in moderately good condition with one collapsed section. Removal of the trees would help preserve it. The fireplace foundation suggests it was built before 1830. It is one of the larger cellars in GMF. It may have been expanded over the years.  
 COORDINATES: 41°56'24.31"N; 73°16'2.23"W

### Importance

This is one of the best homestead sites we found in GMF. It is replete with so many legacy features condensed into a small space (~30 acres) that we felt it should be mapped closely and presented with more detail than other sites. That it is so close to Yale Camp makes it better still.

It is rare to find an entire farm lie as an unaltered landscape legacy in New England. Since most of the farming occurred in flatter areas of low elevation, those areas remain inhabited at best, and paved-over at worst. Here, farming was at its fringe and the poor productivity of the mountains lead to farm failure in a changing economy. And today, when we view the landscape as a historical and ecological landscape, we find the two inseparable.



The two stones in the center foreground in this image are the steps that lead into the barn at the Dorman site. The tree in the center-background sits on rocks that served as the center-post for the barn. The barn is located on Chatleton Road and likely served as a staging for the sale of products to travellers and for bringing products to Meekertown and Lower City.  
 COORDINATES: 41°56'20.99"N; 73°16'0.79"W

### Research Ideas

- The progression of pasture succession: dates, composition, processes
- Historical research into ownership and farm production. Who lived here?
- What did they produce?
- Wildlife use of cultural landscape legacies (stonewalls, old pasture trees, etc).
- Succession in old fields: why maple and why not oak?



This clearance cairn lies in the northeast corner of the Dorman site where a number of stone dumps also occur. The northwest corner also contains clearance cairns, though smaller than this one. Clearance cairns indicate pasturing or crop production where smaller stones are laid upon larger, unmovable rocks. Note the paper birch in the background, indicating relatively recent abandonment.  
COORDINATES: 41°56'28.05"N; 73°15'58.62"W



This barbed wire fence occurs in the northern reach of the site. Barbed wire hems in the farm on its northwest edge backing to the forest. Much of this can be found strung in oaks and on the ground. Barbed wire was popularized in the 1870s, primarily for cattle since sheep get their wool caught up in it. By cutting one of these oaks, the exact year this wire was strung could be obtained.  
COORDINATES: 41°56'32.31"N; 73°16'2.16"W

## Resources

- Allport, S. 2012. *Sermons in Stone: The Stone Walls of New England and New York*. Countryman Press.
- Thorson, R. 2004. *Stone by Stone: The magnificent history of New England's Stonewalls*. Walker and Co.
- Gaige, M. 2006. *The use of abandoned pasture trees (wolf trees) by birds and mammals in second growth forests of Vermont*. Master's thesis, Antioch University New England.
- Gaige, M. 2014. *Wolf trees: elders of the eastern forest*. *American Forests*. 120(3): 16-23.

- Foster, D. G. Motzkin, and B. Slater. 1998. *Land-use history as long-term broad-scale disturbance: regional forest dynamics in central New England*. *Ecosystems* 1: 96-119.
- Wessels, T. 2010. *Forest Forensics: A Field Guide to Reading the Forested Landscape*. Countryman Press.
- Winer, H. 1955. *A history of Great Mountain Forest*. Yale University Dissertation.



Note the branches reach to the left on this tree, while no branches reach right. The tree grew on an edge: forest to the right, and pasture on the left. The plant community types are dramatically different on the forest side of the tree compared with the second-growth side. 41°56'22.49"N; 73°16'6.13"W



This small grassy clearing at the Dorman site was a charcoal hearth. Bits of charcoal can be found around the edges. Vegetation typically remains sparse on old hearths. Perhaps Dorman (or later inhabitants) sold charcoal or rights to it as a farm commodity. 41°56'24.29"N; 73°16'6.45"W



A confluence of stone walls in the center of the Dorman site. It is unclear what this central "paddock" area was for, but could have been for penning animals for brief periods. 41°56'23.41"N; 73°16'2.96"W



Well-preserved stone fence along the northeast border of the Dorman site illustrates the quality of work that went into fence construction. On top of this would have been wood or other material to attain the height necessary for keeping animals penned. 41°56'29.14"N; 73°15'57.90"W



This stone wall, internal to the Dorman site, contains small and large stones heaped rather than stacked. Small stones indicates some level of cultivation, and the removal of stones from such a field. The sugar maples here can be seen in the 1934 image. 41°56'25.86"N; 73°16'2.63"W



A large spreading sugar maple legacy tree from the Dorman site. Many of these trees pre-date the settlement of the farm and are over 200 years old. Legacy black cherry trees also occur. The spreading form shows they formerly grew in an open setting. They are outstanding wildlife features. Shade now threatens their longevity. 41°56'23.99"N; 73°16'3.70"W

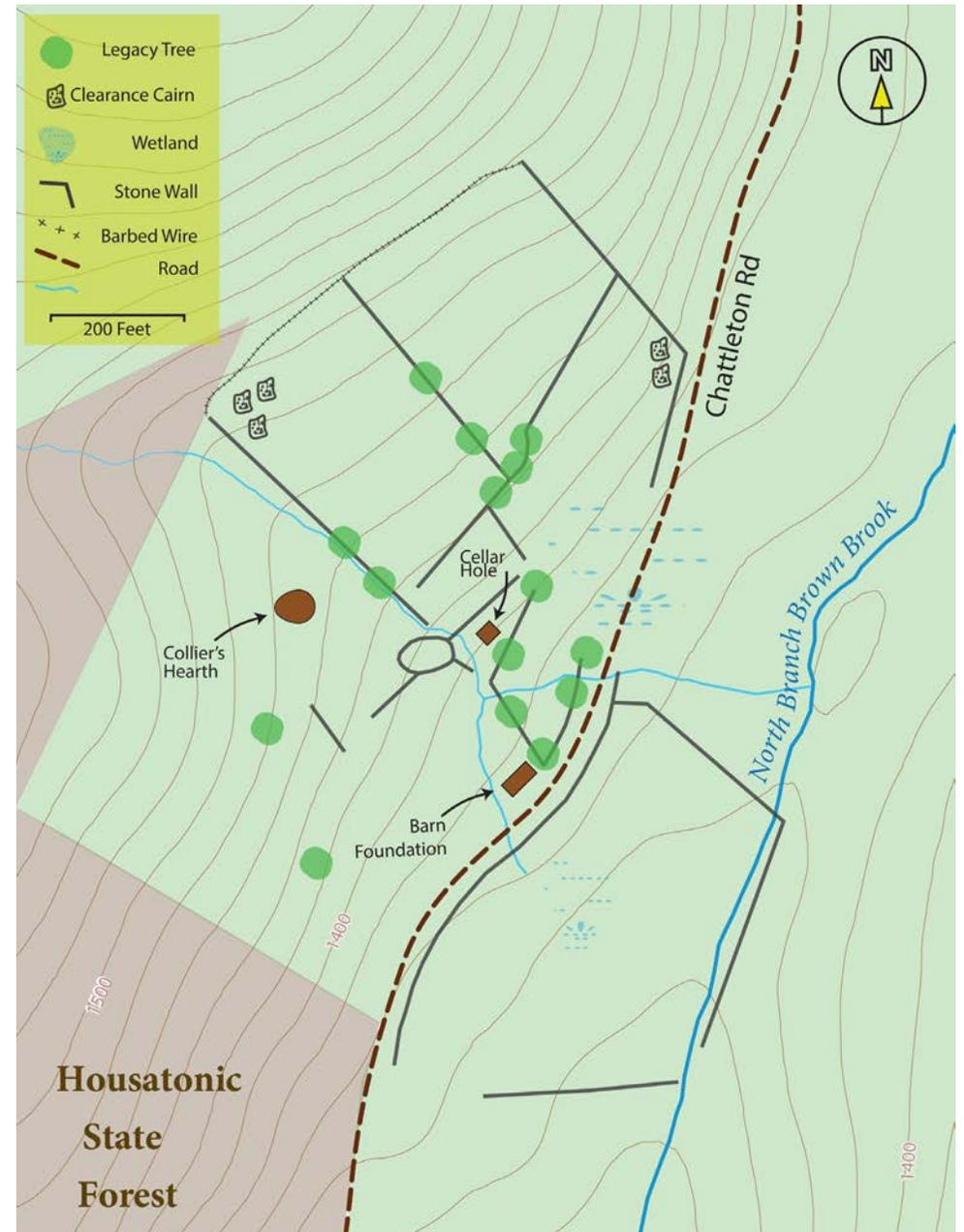

Map of Dorman Site.

## LAND USE HISTORY 7: PIONEER CABIN ON NUMBER 4 TRAIL

### Summary

This site represents perhaps the smallest settlement site we identified in GMF. It consists of a small cabin foundation (earthen, not stone) and other stone features. The vegetation and cultural features showcase the site's history. This is a good, small site to challenge beginners with the process of reading the landscape.

### Access

Number Four Trail to Wapato Pond Overlook parking area. Continue down Number Four Trail to an opening from a cut on the left. Site is ~200 feet in. The cellar hole occurs on the skid trail; rest of site on the side south of trail.

### Location

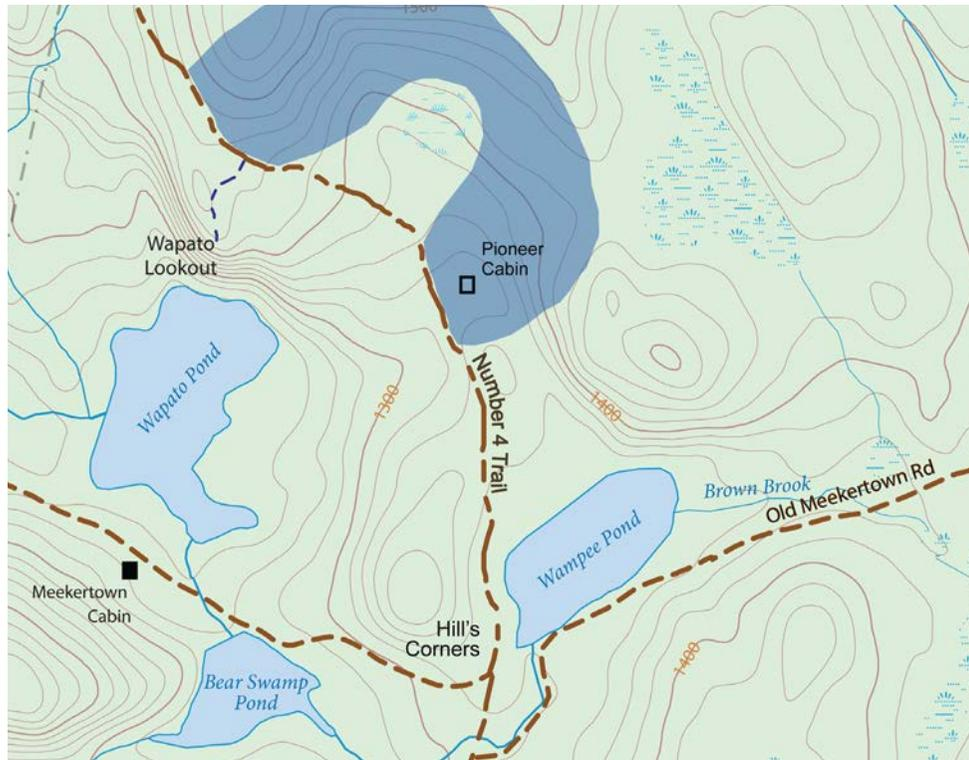

Map of Pioneer Cabin area.



The earthen cellar hole from the pioneer cabin on the Number Four Trail. It was a small cabin, maybe 12x10 feet.

41°55'58.37"N; 73°14'56.58"W

### Near-by or Comparative Sites

Several forest management sites occur in this area. A stand of old tulip trees occurs to the east near a swamp.

### Description

This small but excellent site contains a handful of cultural features and a few ecological features that together tell a short story of early habitation. The first feature is the cellar hole. The cellar is earthen, not stone. It is shallow, but still dug indicating that people were spending winters here and storing food in the cellar. The cellar is approximately 10x12 feet. Its intention may have been for temporary use and for this reason not built of stone. Certainly, there is no shortage of stone on the site.

Across the skid trail (southeast) a short distance one finds other features. Several clearance cairns, containing no more than a few stones, dot the site. The makings of a stone wall, as incomplete and insignificant as it is, lines the edge on the downhill side. The inhabitants likely were growing food by hoe in this area, working around the larger stones, and moving only the smaller ones. This was a simple, but perhaps hard, life.

The vegetation also speaks to this history. A fallen dead eastern



The fallen eastern red cedar at the pioneer cabin. Cedar is an early successional tree requiring full sun to establish. Its presence here tells of us of the open farm environment on the site a century prior.

red cedar lies close to the stonewall. Cedar is an early successional tree requiring full sun for germination. This indicates the site was formerly open, despite its present forest cover. The tree is about nine inches in diameter, suggesting it was 80 years old when it died. Cedar is slow to rot and fall, so this tree may date to the 1800s when it germinated. Coring the tree could provide an accurate age, but the age that it died can only be speculated on. A tangle of grape vines weaves through the interior of the site. Grape is also an early successional, sun-loving plant. However, it is possible that pioneers planted them. Grape is notoriously difficult to identify to species.

### Importance

In the spectrum of the scale to which people settled what is now GMF, this site ranks as the smallest footprint and extent, but still leaving an imprint. When compared to the Dorman Farm, the Dean Farm, or even the Mansfield site, this pioneer cabin was a small enterprise. The site is small, and the features are apparent, and so this site is excellent for beginners to



A small clearance cairn at the Pioneer Cabin on the Number Four Trail. The site contains several small clearance cairns, and a small length of wall. This was a small, single family or single person operation. Also note the tangle of grape vines (*Vitis sp.*) in the background. These also indicate the disturbed nature of the site and may be agricultural relicts.

the process of cultural landscape interpretation.

### Research

Historical research to find out who owned/settled this site and when.

Can anything be found in the cellar hole and is it in fact earthen and not stone?

Coring trees could reveal when the site was abandoned. Coring the cedar would help with that mystery.

## LAND USE HISTORY 8: BROWN BROOK SAWMILL

### Summary

This site displays the remains of one of Great Mountain Forest's many 19th century sawmills. The site contains basically three features: the dam; the mill remains; and an unknown foundation. This may have been one of the larger, more significant mills and its robust construction has allowed its persistence for over 160 years. As such an important aspect of GMF history, as well as its present day operations, the sawmill represents a significant feature in the forest's story. Understanding the mill is important to understanding the ways people have made habitat from this land.

### Access

Easiest approach is from Yale Camp, past Dorman site to Meekertown. Alternatively, Number Four Trail to Meekertown cabin and beyond. Either way, expect a good walk on trails until reaching the site.

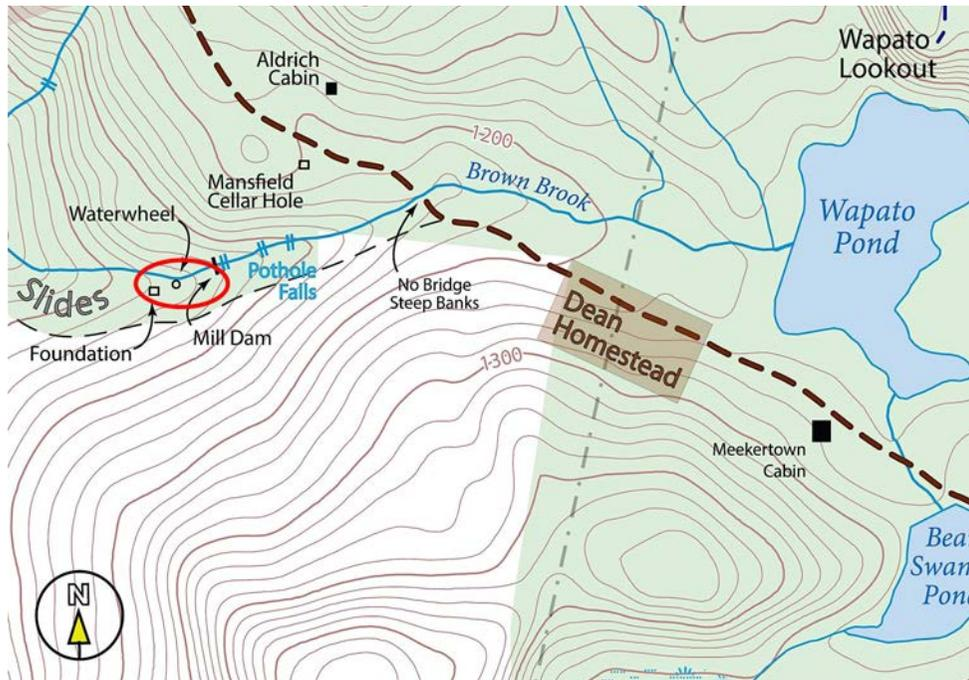

Location of the sawmill structures in Meekertown. The site contains three structures: dam, waterwheel house, and a foundation.

### Location

41°55'44.39"N; 73°16'1.97"W

### Near-by or Comparative Sites

Meekertown is full of homesteads including E. Mansfield and S. Dean. Around this sawmill on the far side of the stream are a few charcoal hearths.

### Description

The site displays three main features that comprise a significant and robustly built sawmill on Brown Brook in Meekertown. (According to Eldridge (1900) Phineas Meeker, namesake of Meekertown, married Sarah Brown in 1764. Brown is probably the namesake for Brown Brook, the power behind the sawmill.) The first feature is the dam. It sits at the top of a waterfall and stretches ~100 feet across the stream. The rocks comprising



The 1853 (Fagan) map of Canaan, Conn. showing Meekertown (upper right) and Hunt's Lyman Ironworks of lower city (bottom left). The two foundations remaining for this sawmill are circled. No sign of the sawmill farther upstream remains. A lower sawmill is off GMF property and any remains were not verified.

the dam are huge, up to approximately 20 cubic feet, which would weigh 3500 lbs. The construction of the dam is impressive. Floods have blown out the channel, but the majority of the dam remains.

The second feature is the mill, 50 yards or so downstream from the dam. There is a cylindrical well which, by way of a sluice, would have powered a wooden wheel, moving a reciprocating saw above. The stonework on this feature is also impressive in appearance and by the fact it has held up for over 160 years. The third feature, 50 feet downstream from the mill, is a stone foundation of about 20x20 feet. It is unclear what the building's purpose was. But once again, the stones are large and it was built to last.

The Fagan map of 1853 shows the sawmill and the other features of Meekertown and beyond.

In addition to the cultural history, the site at the waterfall below the dam contains American fly honeysuckle (*Lonicera canadensis*) and Canadian yew (*Taxus canadensis*). These are uncommon or rare plants in GMF and regionally. Watch your footing.

### Importance

This sawmill is yet another excellent cultural feature at GMF. This is the type of feature that a national park would highlight, learn about, and interpret in a way the public can safely explore and learn. The sawmill represents a significant element in the forest's story. Understanding the mill is important to understanding the ways people have made habitat from this land. This site ranks high on the list of cultural sites.

### Research

What did the sawmill look like and how did it function?  
Was the wood used locally or did it supply a market farther away?  
How was it built and the stones moved?

### Resources

*Eldridge, J., and T.W. Crissey. 1900. History of Norfolk 1764-1900 Litchfield County, Connecticut. Massachusetts Publishing Company.*



Dam site for the millpond at the Brown Brook sawmill. The stones are impressive in size and number. The site was built on a massive investment in human labor.

## LAND USE HISTORY 9: DEAN FARM AT THE JEAN TRAIL

### Summary

This is an excellent site about 30 minutes walk from Yale Camp that displays another example of people making a living from the land. The former agricultural lands are now covered in Norway spruce plantation. However, the ground, the trees, the cellar holes walls, and apple trees paint a reasonable picture of the site's history. The site is especially useful when contrasted with the Dorman site, and visa versa.

### Access

The site is located on the Jean Trail, which provides the best access. Much of the site is located off of GMF property, however, permission has been granted to use it. Inquire with GMF prior to visiting.



Quartzite boulder from the Dean Farm. The boulder has two large flakes removed (shown here where the pine needles had settled). These are likely Native American flake removals. The stone is about 3 feet in diameter.

### Location

Main cellar Hole: 41°57'28.21"N; 73°15'57.69"W

Use this main location as a starting point, and then use the large map below for further exploration.

### Near-by or Comparative Sites

The Dorman site (this section) provides an excellent comparison. The two farms are similar in size, similar distance from Yale Camp, but differ in their environmental setting, history, and contemporary composition and structure.

### Description

Evidence of this site's human history begins with a quartzite boulder located 200 feet SSE from the main cellar hole. A couple large flakes have been removed from the boulder (see photo) suggesting resource use by indigenous Americans hundreds or thousands of years ago.

But the thrust of this site is more recent land use history. We begin with the nucleus of the farm: the cellar holes. Two cellar holes occur at the abovementioned GPS point. The first is larger, deeper, and also more thickly covered in vegetation. The second lies to the east. The first hole

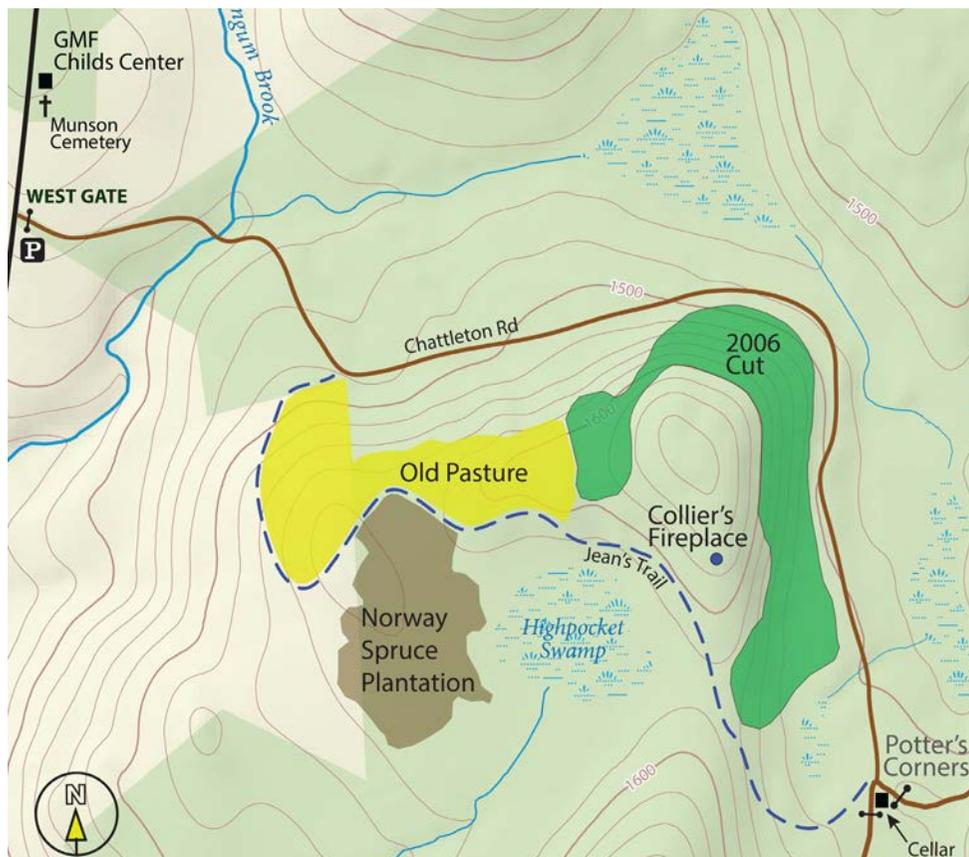

Map of Dean Farm location.



Norway spruce plantation on old crop field indicated here by smooth ground and stone wall dump. Spruce was planted 1962. Note that moss is largely absent on the quartzite stones.



Apple tree among Norway spruce plantation at the Dean Farm cellar hole.

clearly suggests a house site. The lack of a central fireplace suggests it was built after 1830 when stovepipe became common. The site does not appear on the 1853 (Fagan) map of Canaan, so likely post-dates that year as well. The second cellar is smaller, shallower and it is unclear what its function was. It could have been a house for children or elders, or a barn, or cider house. Apples were just beginning as an industry in the mid-1800s and Canaan would have had rail-to-market access by 1860. There are several apple trees still on the site today. Nonetheless, the cellar hole suggests people were storing food below ground.

Stone walls on the farm are mapped on the large map that follows. The walls are generally loose, unformed stone dumps except for one along the Jean Trail that appears to be stacked into a fence for domestic animals. We identified the space to the north of the wall and trail as pasture. The area has bedrock at the surface, no smooth ground to indicate crops, and the wall contains no small stones. A few strands of barbed wire also indicate pasture, specifically for cows (not sheep as their wool gets caught in the barbs).

The stones in the walls are largely quartzite and are similarly sized. The wall clearly differs from other GMF walls in its geology. This suggests a different glacial or geomorphic history of this site (or at least a different



Old farm road through woods, now the Jean Trail. The left side of the formerly open grown sugar maples was pasture, indicated by lumpy ground, bedrock, and a stone fence. The right of the road is now plantation and was formerly crop fields.

source of glacial sediment). In addition to the quartzite, there is also a block of marble located 150 feet SSW from the abovementioned quartzite boulder. This block also must have been glacially deposited from several miles farther north. Perhaps additional marble was deposited here creating richer soils indicated by a large basswood tree. Basswood and calcareous soils are atypical for GMF and Canaan Mountain in general (see geology section).

Somehow, Dean, or the original settler (if someone else) identified this site as being rich and carved out a living here. Settlers often recognized sugar maple and basswood among other trees and plants as indicators of rich soils. Nonetheless, the farm didn't last—it was gone in less than 100 years. The site doesn't appear on the 1853 map. Childs bought it by the 1950s and planted spruce in the 1960s.

The dominant feature today is the spruce plantation. A look at the ground among the spruces reveals completely smooth ground, indicating previous cultivation. GMF history suggests the plantation site was once an old potato field. The land was leased to the Torrington Brass co., which permitted workers to grow potatoes for themselves there. Undoubtedly, over the years a variety of crops were grown in these fields. The former fields stretch away to the south. Today this area has become an impenetrable thicket of Japanese barberry.

The Norway spruce plantation was planted from 1962-64. The trees are now over 50 years old. The species was chosen for growing fast. The pines mixed in were tiny when the spruce were planted, or seeded in later as the plantation self-thinned. Several of the pines have been girdled with an axe. Since the spruce was planted and pines girdled, the site has seen little activity. However, the opening along the Jean Trail is maintained by mowing. There is a research plot of unknown origin among the spruces, evidenced by the tagged trees of mixed species.

### Importance

The Dean Farm offers an excellent site for uncovering land use history and observing the way people have made a living from this landscape during different economic-cultural periods. The site also contains one of the few Native American relicts in GMF (quartzite boulder with flakes removed).

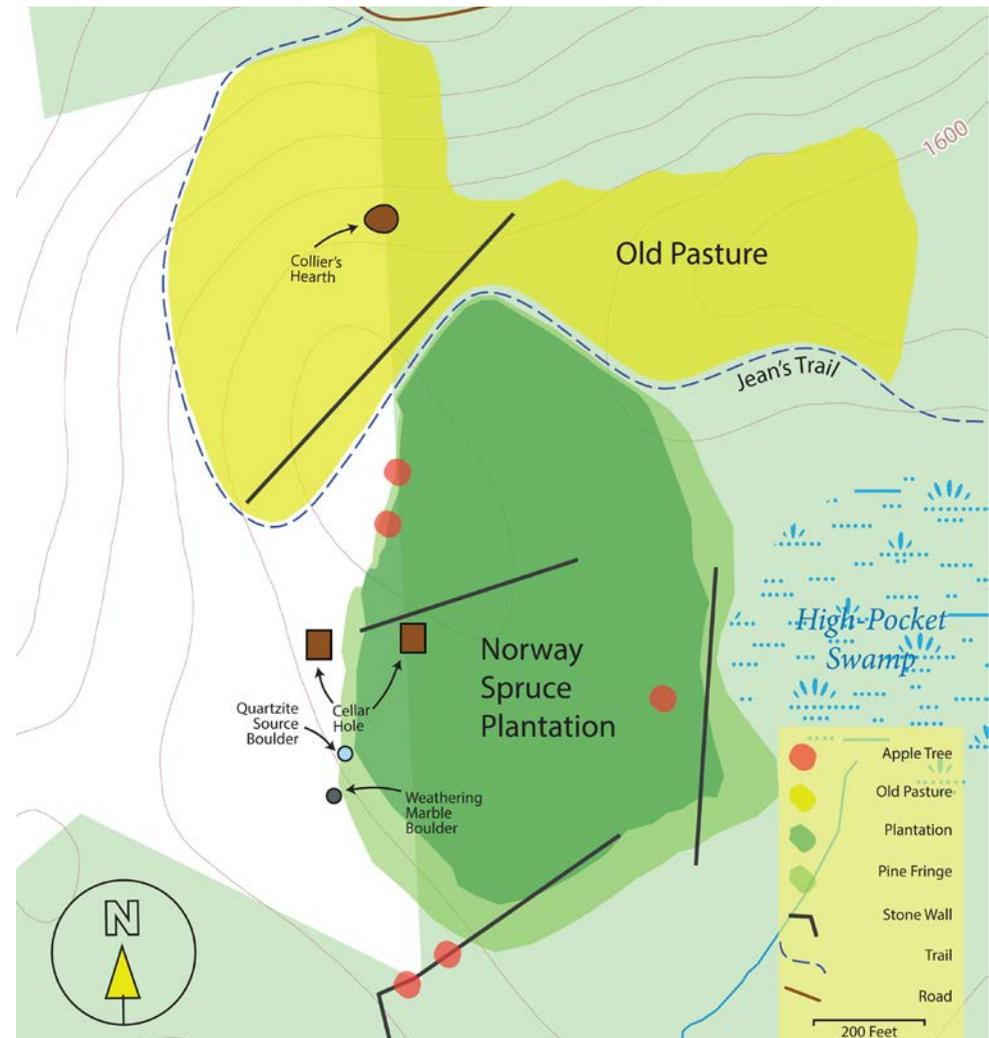

### Research

Soil changes in the spruce plantation after half a century of agriculture and half a century of Norway spruce plantation.

Additional soil and geomorphic study to reveal the site's history.

Comparisons of soil among the plantation, pasture, and natural succession sites.

Growth rates of Norway spruce.

### Resources

Wessels, Tom. 1997. *Reading the forested landscape: a natural history of New England*. Countryman Press.





# FOREST MANAGEMENT

AT GREAT MOUNTAIN FOREST

The Great Mountain Forest is well known for its beautiful natural communities and the story of its human legacy, but it is also actively managed for a variety of economic, educational, and environmental objectives. Since the early days of Childs and Walcott, GMF has striven to serve as a model for forest management that sustains and strengthens the integrity of the ecosystem, serving human stakeholders as well as plants and other creatures.

Silviculture, in its broadest sense, means using principles of ecology to guide the management of trees and forests. Although practiced meticulously for many years in countries like Germany, the seemingly boundless expanses of old growth forest in the United States fueled centuries of waste and decimation with no plan for the future. The U.S. Forest Service was officially established in 1905 (first as the USDA Division of Forestry in 1881), to address concerns of an impending “timber famine” by employing scientific silviculture methods for sustainable yields and growth across federal forest lands. Gifford Pinchot, the first Chief Forester for the new agency, (and co-founder of the Yale Forest School) wrote in 1907: “Unless we practice conservation, those who come after us will have to pay the price of misery, degradation, and failure for the progress and prosperity of our day.” The initiative to acquire and sustainably manage federal lands was part of a larger growing environmental movement—an awakening consciousness of the limits to unbridled resource depletion.

The Great Mountain Forest is very much a product of such emergent land use ethics, though the manifestation of their mission has evolved over time in step with shifts in forestry science and environmental culture. The early days of Childs and Walcott were part of the generation

dominated by figures like Theodore Roosevelt, concerned with improving game habitat and hunting practices that sustained their populations. They planted trees, dug ponds, and imported animals to help achieve their social goals. Forestry in the traditional sense of the term (that is to say, concerned with timber production) didn't get underway at GMF until the 1940s, under the careful guidance of Ted Childs and his succession of hired foresters—most notably Darrell Russ and, later, Jody Bronson. Prescriptions for harvesting were always conducted with an eye to sustainable yields and preserving the integrity of the ecosystem, and over the years became more sophisticated as new technologies and methodologies of landscape management came into vogue.

The sites in this section are ordered such that they follow GMF's forest management practices, more or less, through this progression of ideas. We start with the various tree plantations (Plantations) that are scattered throughout the property; interesting, though representative of an old fashioned forestry practice that is now rarely employed in the New England region. There are then examples of five timber treatment sites (High Pocket, Skyline Drive, Wapato Lookout, Lowland White Pine, and Red Pine Salvage), selected to demonstrate a range of nuanced silviculture techniques. These sites are followed by descriptions of the harvesting of two non-timber products (Witch Hazel, and Maple Syrup), which have their own specialized niches in terms of markets and management practices. The final two sites (NRCS Bird Habitat, and New England Cottontail Habitat) are examples of silviculture operations specifically designed with the aim of creating habitat for target animal species, a practice becoming more common among conservation organizations.

### Resources

*Pinchot, Gifford (1907) The conservation of natural resources. The Outlook 87: 291-294*

*Smith, D.M., B.C. Larson, M.J. Kelty, and P.M.S. Ashton (1996) The Practice of Silviculture: Applied Forest Ecology, 9th ed. John Wiley and Sons, Hoboken.*



The Great Mountain Forest Office: where the magic happens.

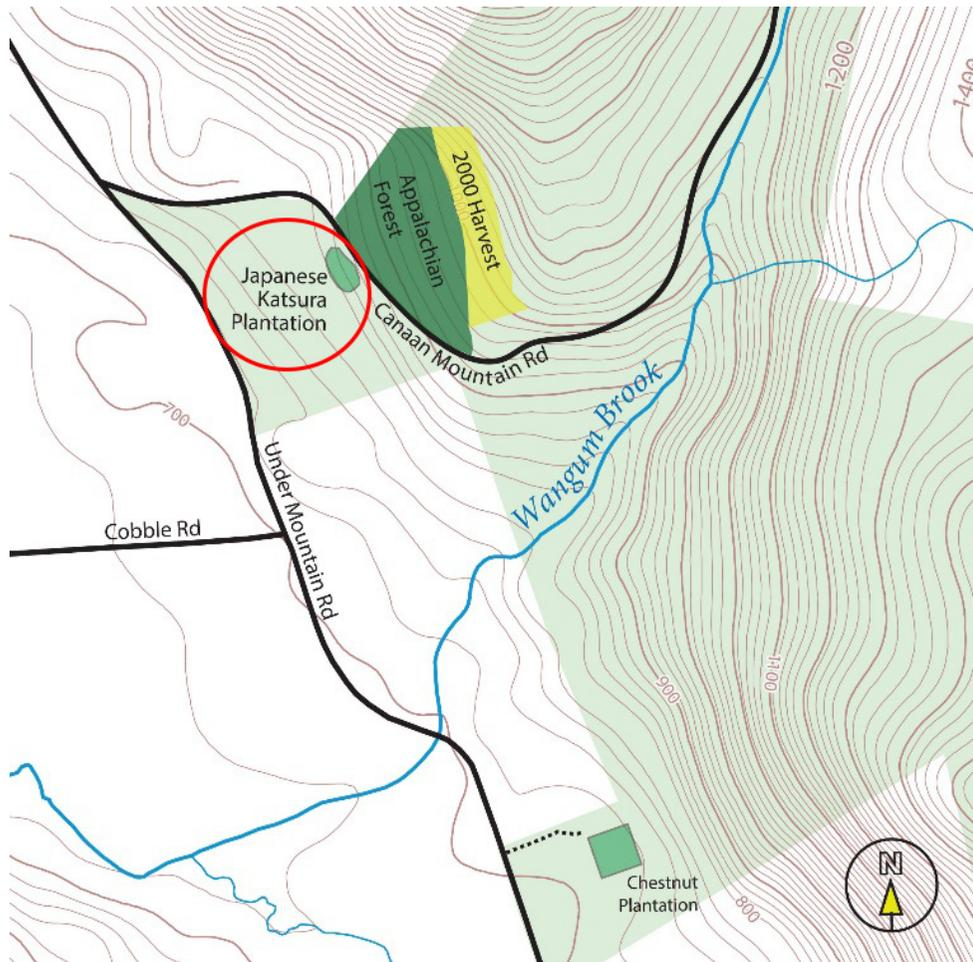

Katsura/Dawn Redwood: N°41 56'54.54"; W°73 16'58.76"

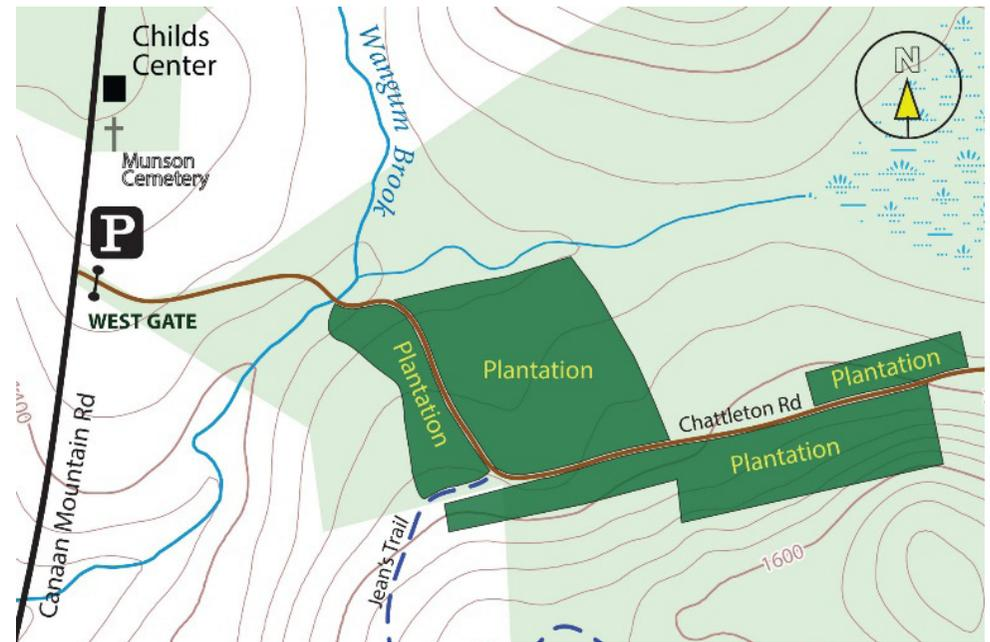

Exotic Conifers: N 41°57'39.24"; W 73°15'16.23"

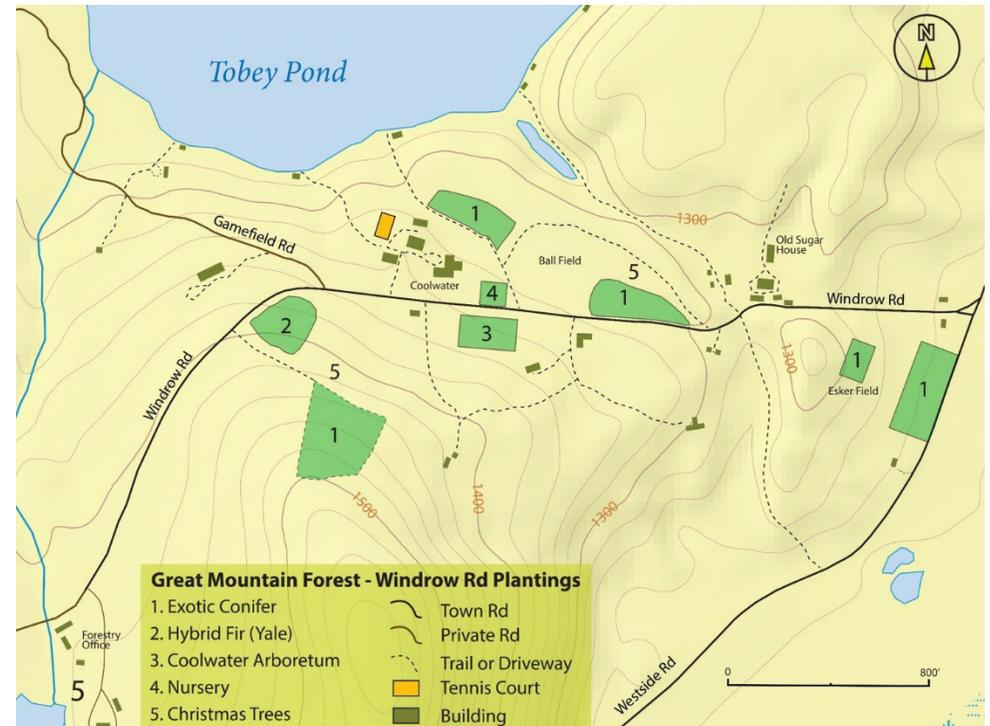

Coolwater Plantings: N 41°58'12.48"; W 73°13'26.52"

## FOREST MANAGEMENT SITES 1: PLANTATIONS

### Summary

A brief overview of the various tree plantations that exist at GMF, from the arboretum at the Coolwater estate to the exotics planted by Ted Childs and Darrell Russ from 1959-1976. Though no longer part of any active research or conservation effort, those plantations still standing offer an opportunity to see many species unusual to the region, and continue to be a distinctive feature of the forest.

### Access

The major plantations are arranged in two main clusters. The so-called “Coolwater Area Plantings” lie along Windrow Road, to the south of Tobey Pond. Visitors may park at the Forestry Office and walk to them, or else obtain permission to park at the Coolwater residence.

The Exotic Conifer plantations lie along either side of old Munson and Chatleton Roads, soon after crossing the bridge while heading south to Yale Camp. Another set of plantations, which includes the katsura (*Cercidiphyllum japonicum*) stand, occurs along the south side Canaan Mountain Road, heading north to the Mountain House from the intersection with Under Mountain Road. Visitors may park in any of several clearings to the side of the road near there (see appalachian forest in Natural Communities for location and information).

### Location

See included maps.

### Nearby or Comparative Sites

Three of the research sites covered in this field book are plantations in their own right, often with similar goals: The Chestnut Plantation (Research Site 3), Mergen’s genetic studies (Research Site 4), and the Pitch Pine Study (Research Site 5). See also the red pine salvage site (Forest Management 6). Spread as they are across different regions of the forest, the various plantations today lie nearby too many sites of interest to name here (see maps).

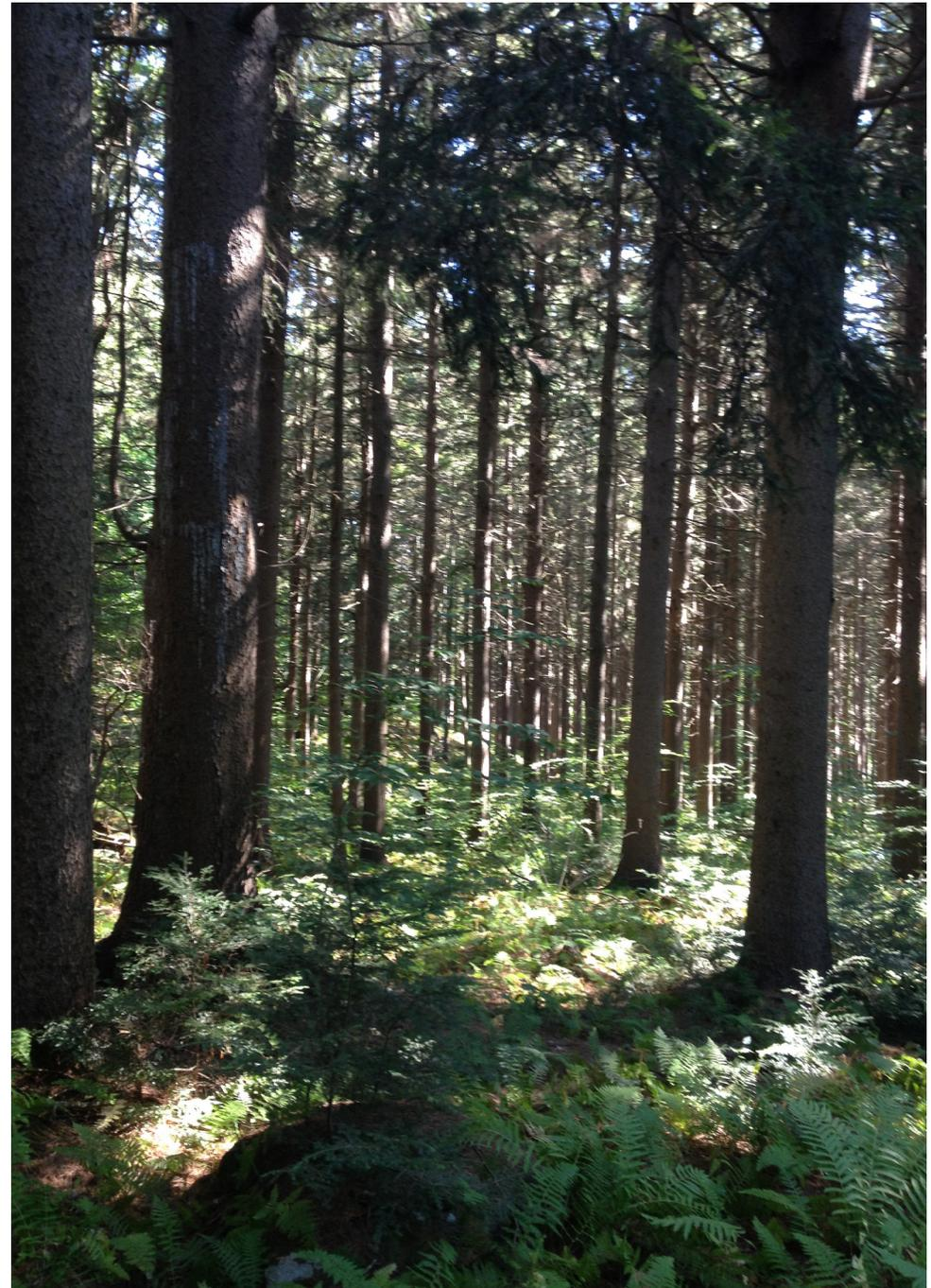

The Norway spruce plantation on Camp Road near the Forestry Office, planted in 1919. These trees are much larger, and have been thinned to allow for more space between plantings, permitting a lively fern and shrub understory to develop.



Close up of the katsura tree bark.

### Description

The various plantations that dot the GMF landscape are among the forest's most unique and distinctive human legacies. When Ted Childs began to take over operations beginning in the 1930s, he used his background in forestry to shape the landscape. The forest was young in those years, still recovering from a century of fires and repeated clear cutting under the auspices of the charcoal industry. As was in vogue at the time, one of his first activities was to establish tree plantations in denuded areas. In many cases, these were former agricultural sites that had just recently been abandoned.

The earliest plantations were planted near and around the family's Coolwater estate along Windrow Road. These were gradually added to over the years to make an expansive cluster that stretched north to Westside Road, west to Tobey Pond, and south to the Forestry Office (see map). Included among these plantings is the Coolwater Arboretum, which features various hardwood and coniferous species (both native and exotic) planted in artful arrangements. A section to the south next to the intersection with Gamefield Road was set aside in 1971 for Francois Mergen's hybrid fir study.



View of the katsura plantation canopy. The straight and tall growth form makes katsura a prized timber species in its native Japan.

Immediately north of the Coolwater house was the nursery, used to supply various spruce, fir, and pine growing stock for Christmas tree cultivation, which was once a significant non-timber forest product of GMF. Once big enough, saplings were transplanted to the Christmas tree plantations, mainly located along Under Mountain Road, where they would grow to a harvestable size within 8-12 years. Production of Christmas trees was in decline by the early 2000s, and stopped altogether by 2004. Much of the land where they were once grown is now owned privately by members of the Childs family, and are no longer within the official boundaries of GMF. The Chestnut plantation is actually planted on one of the former Christmas tree plantation sites. The nearby cultivated stands of Scots pine and quaking aspen are lingering relicts from that earlier era.

In 1959, Ted Childs and head forester Darrell Russ began a new set of plantations on the Canaan side of the forest, along Munson and old Chatleton Roads. As part of a long term adaptability study, they collected and planted pine, spruce, fir, larch, and cedar species from all around the world. This exotic conifer planting mania would consume Ted and Darrell's interest and efforts for the next seventeen years, ultimately resulting in 69 individual stands representing 31 species. Most of the trees were purchased



Close up of the leaves of the katsura tree. The heart shape resembles the leaves of the unrelated redbud tree (*Cercis* spp.), which is where the katsura genus name is derived (*Cercidiphyllum*, “Cercis-like leaves”).

from local nurseries such as Musser and Itasca. However, according to GMF folklore, on one occasion Ted smuggled pine seeds to the U.S. by hiding them in his shoe. Many of these stands are still in solid shape to this day, now with signage designating the species, country of origin, year planted, and treatment history of each.

Additional exotic conifers were planted by the Coolwater estate, as well as along Canaan Mountain Road, across the street from the Appalachian forest area (see Natural Communities 6: Mixed Appalachian Forest). This last stand, which contains grand fir (*Abies grandis*), western red cedar (*Thuja plicata*), and a small grove of dawn redwoods (*Metasequoia glyptostroboides*), was also planted with several broadleaf species: an experimental plantation of native American chestnut (*Castanea dentata*) in 1962, the highly invasive, though medicinal, Amur corktree (*Phellodendron amurense*), and a stand of Japanese katsura (*Cercidiphyllum japonicum*) in 1978. Katsura is Japan’s leading lumber species, prized for its soft, light wood. Ted thus sought to corner the katsura timber market in Connecticut, where it is only grown ornamentally in urban settings. Today the trees have grown huge (70+ ft.), owing perhaps to the rich limestone soils where they are planted, which the species prefers. The species is escaping and growing



The Norway spruce plantation on Chattleton Road, planted in the 1960s. The trees still grow so densely that no herb or seedling can establish in the understory.

from seed on the flat bottomland of this site leading to, yet another, exotic species outbreak.

Though interesting for their history and botanical specimens, these sites have far lower species and structural diversity when compared with the surrounding forest. Such plantations, with their tight rows of dense shady conifers, exclude the regeneration of trees and herbs in the understory. This effect is particularly stark in the Norway spruce plantations, along both Chattleton Road and Jean’s Trail. In some areas, as with the katsura stand, the planted exotic species have begun to naturalize by reproducing outside the planted area, with potentially harmful long term effects.

In the aim of maintaining a functioning, self-replenishing forest ecosystem, plantation forestry in the New England region has long been rejected in favor of naturalistic harvest methods, as is practiced at GMF and outlined in the succeeding management site selections. Though the various plantations are periodically thinned and maintained for their timber and sentimental value, they have not been added to for over thirty years, and there are no current plans to replace the trees when they die or are harvested. In time, they will revert to the composition of the surrounding forest matrix.



## FOREST MANAGEMENT SITE 2: HIGH POCKET TIMBER HARVEST

### Summary

A timber harvest parcel that was logged in 2002 and 2006. The goal was to create a shelterwood cut, promoting the regeneration of new red oak seedlings—a common approach at GMF.

### Access

The site lies just to the west of Chattleton rd., along Jean's Trail to the south.

### Location

See included map.

### Nearby or Comparative Sites

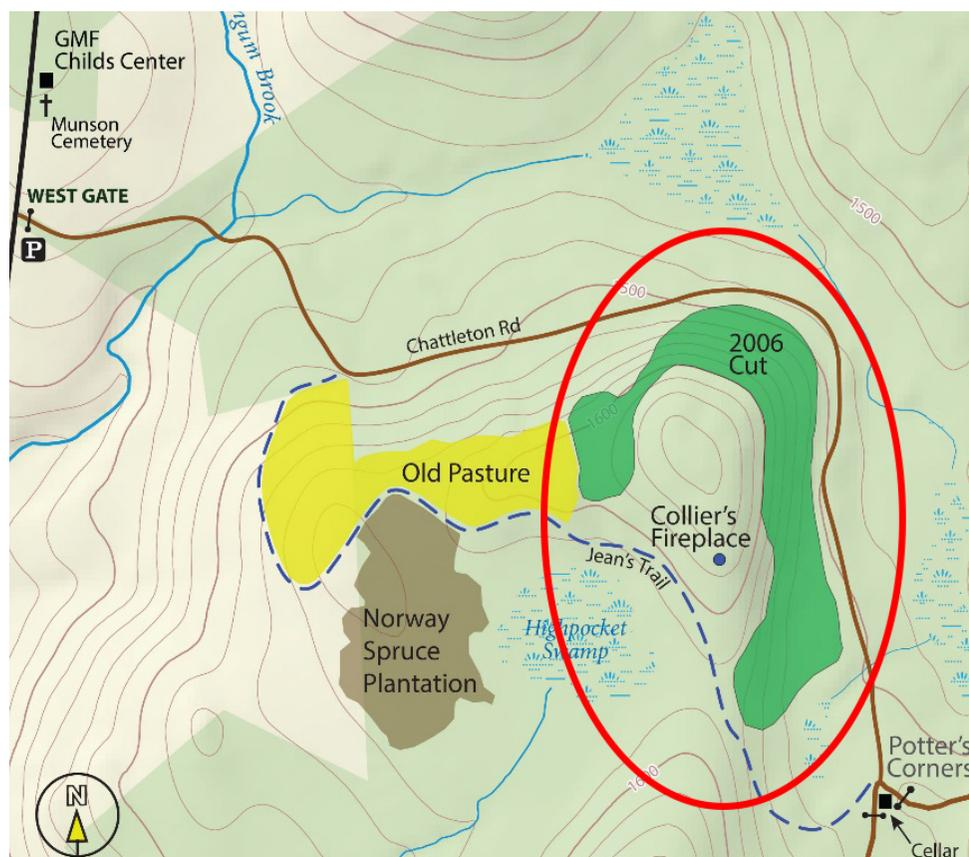

High Pocket Timber Harvest: N 41°57'18.91"; W 73°12'23.70"

This harvest gets its name from being next to the High Pocket Swamp described in the Dean Farm Site (Land Use History 9). Potter's Corners cellar hole site (Land Use History 10) lies just to the east.

### Description

As with many harvests in Great Mountain Forest, the goal was to promote the regeneration of oak by clearing large gaps in the canopy, thereby leaving sturdy trees to provide the seed source. Trees like oaks, chestnuts, walnuts, and beeches are all mast species. Their main dispersal strategy is to produce, as groups, copious quantities of protein rich nuts during particular years, so as to overwhelm and satiate their seed predators. Foresters must time their harvests carefully to coincide with these mast years, to ensure that there is ample regeneration of the desired species. Timber harvests must also be conducted with an eye to appropriate weather conditions and the relative strength of timber markets—a dance that Jody and Russell must perform with mastery to keep operations afloat.

This 32-acre area was first harvested by GMF in 2002. Prior to the cut, the site had a canopy dominated by red oak, with a dense overstory of more shade tolerant beech and red maple. Like much of Great Mountain Forest on the Canaan side, the area had been cut hard for charcoal production during the 19th century. The canopy was undisturbed since that time, with a tree age class of approximately 130-150 years.

Most of the harvests at GMF today are contracted by South Norfolk Lumber Co. They used chainsaws to fell the trees, and a cable skidder to transport logs to the timber truck. Cable skidders are nimble vehicles which use a winch-loaded cable to drag logs from where they are cut to a desired loading location. It is often used for forest operations at GMF, partly because the reach of the chain can be used to gather trees from steep locations that would otherwise be inaccessible (as iterated throughout this field book, such topography is extremely common at GMF). From this site they removed 130,000 board feet (BF) of timber, of which 56% was high value red oak.

Jody returned to do an additional harvest in 2006, removing an additional 8,000 BF of oak. It is not uncommon for foresters to have repeat treatments on an area several years later, if the results of the first harvest are not to their satisfaction. In this case, recruitment of new seedlings was low following the initial cut. Removing the canopy opened up additional light for the regenerating understory, with a goal to stimulate germination.

Today the stand has an abundance of oak saplings dispersed



Regenerating red oak, in the midst of an ocean of hay scented fern. Herbaceous vegetation can quickly colonize growing space opened by timber harvesting, inhibiting the initial establishment of young tree seedlings.

throughout the harvest area. Some gaps have grown back thick with black birch, a pioneer species whose millions of wind dispersed seeds can quickly colonize newly opened growing space.



GMF head forester Jody Bronson (left) at an active harvest site with one of the forestry interns. Note the chain tires on the yellow cable skidder in the background, which provide extra traction when moving cut logs.

## FOREST MANAGEMENT SITES 3: SKY LINE DRIVE TIMBER HARVEST

### Summary

A relatively small harvest area, but with one of the most beautiful views in GMF. The site has been cut twice: in 1996 to remove low quality oak and hemlock, and again in 2014, opening up a small viewshed over a steep ledge on the western border of the parcel.

### Access

The Skyline cut sits on the western side of the Number 4 Trail, just north of Wapato Pond.

### Location

See included map.

### Nearby or Comparative Sites

This site is part of the mosaic of harvest areas that run along both sides of the Number 4 trail. One other of these, the adjacent Wapato Lookout harvest, is covered in this fieldbook (Forest Management 3).

### Description

The goal of this harvest was to promoting regeneration of white oak—common regionally, but rare in GMF, except on dry hill slopes inaccessible to harvest equipment. The 15.2 acre area was first treated in 1998, removing about 35-40% of the mature growing stock, mostly low grade oak and hemlock, and assorted hardwoods that were split for cordwood. Left behind was a motley mixture of white oak, hickories, hemlock, tulip tree, and some white pine.

The ideal scenario prescribed by silvicultural concepts often runs up against the realities of the actual harvest on the ground. As a result, additional measures must often be undertaken to ensure that the operations do not leave harmful environmental impacts. During this harvest, a skid road was constructed on the site to facilitate movement of timber to the landing. The last 50 yards were extremely muddy, and moving vehicles across it would have wrought long lasting damage to the soil community there. To fix this problem, they constructed a “corduroy road” —laying softwood slabs to stabilize the ground for vehicles and equipment.

The site was cut again in 2014, opening up the canopy more

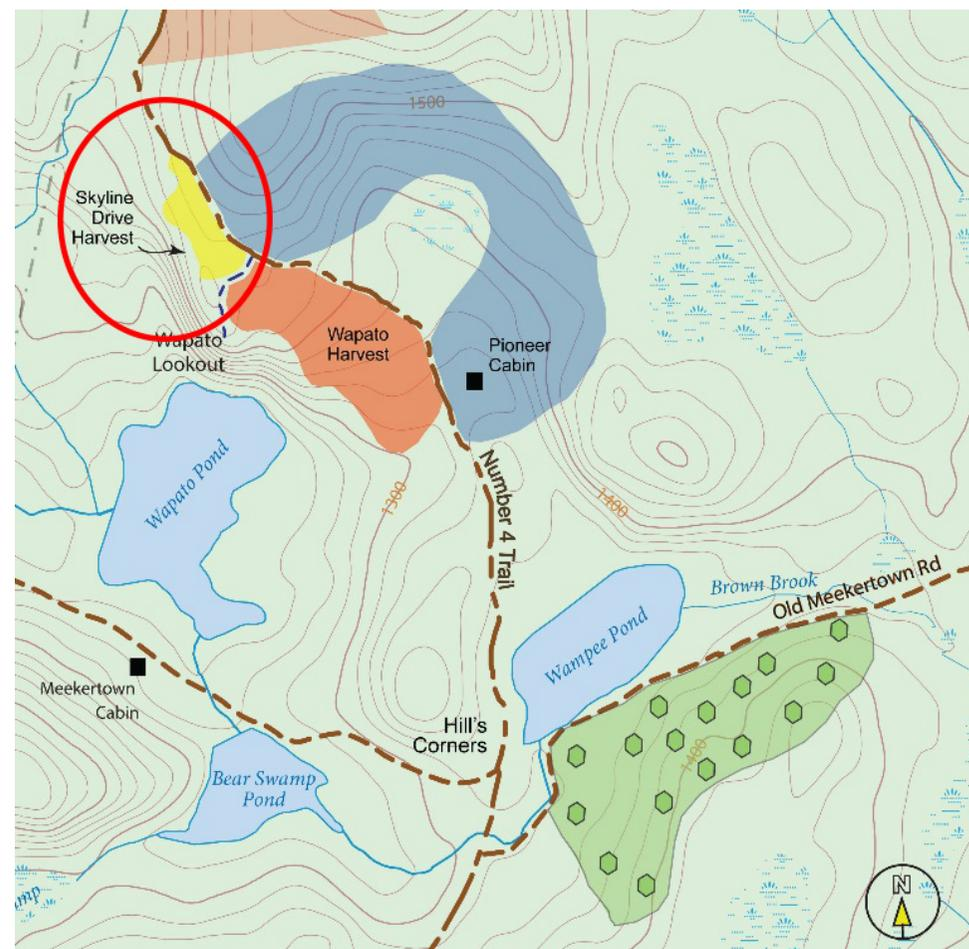

Vista 41°56'2.78" N; 73°15'14.69" W

dramatically to create the west facing viewshed seen today. About 10% of the original trees were left for mast. A year later, the ground story is covered in all manner of blackberries, raspberries, ferns, wildflower forbs, and regenerating trees, many of which must have been established since the canopy was first opened in 1996. The goal of the vista itself was two-fold: removing more oak and white pine to add to the adjacent harvests of that year, while creating a striking view across the steep west facing slope.

As with the nearby Wapato Lookout harvest (next entry), this forest area is noteworthy for its abundant of tulip tree seedlings, a more Appalachian species whose presence has increased in GMF in recent years. Many can be found in the dense ground story of the vista area, and will possibly constitute a significant proportion the future canopy.



## FOREST MANAGEMENT SITE 4: WAPATO LOOKOUT TIMBER HARVEST

### Summary

A more complex harvest involving specialized prescriptions for three distinct stands. Subtle differences in topography, underlying geology, soil type, and land use history, all contribute to the character of given patches within the larger forest matrix. The ability to read complex landscapes is essential for the proper administering of sustainable forest management.

### Access

This site is accessible along the Number 4 Trail.

### Location

See included map.

### Nearby or Comparative Sites

Directly adjacent to the Skyline Drive Harvest (Forest Management Site 3) and the Pioneer Homestead (Land Use History 7). For more on moose herbivory research, see the Moose Exclosure entry (Research Site 1).

### Description

This 2014 harvest was conducted on a much larger scale than the previous two, covering approximately 75 acres. The parcel contains three distinct stands of differing topography and tree composition, and accordingly each was given its own custom treatment. The first stand consists of about 20-acres to the north and northeast, characterized by slow growing oaks and hickories on rocky substrate with a poorly developed shrub layer. This stand was mostly left alone due to inaccessibility, the low timber value of the trees, and its value as an interesting natural community.

The second stand, comprising 37.4 acres across the middle of the parcel, has an oak dominated overstory with scattered large beech, averaging 7,900 BF per acre. In 2001, some of the large red oaks were thinned in order to open up parts of the canopy. This created the conditions for open areas of advance regeneration oak and red maple to establish in the midst of hay scented fern patches. Unlike the first stand, the canopy here was well stocked with merchantable oak trees, with an average diameter at breast height (DBH) of 15 inches.

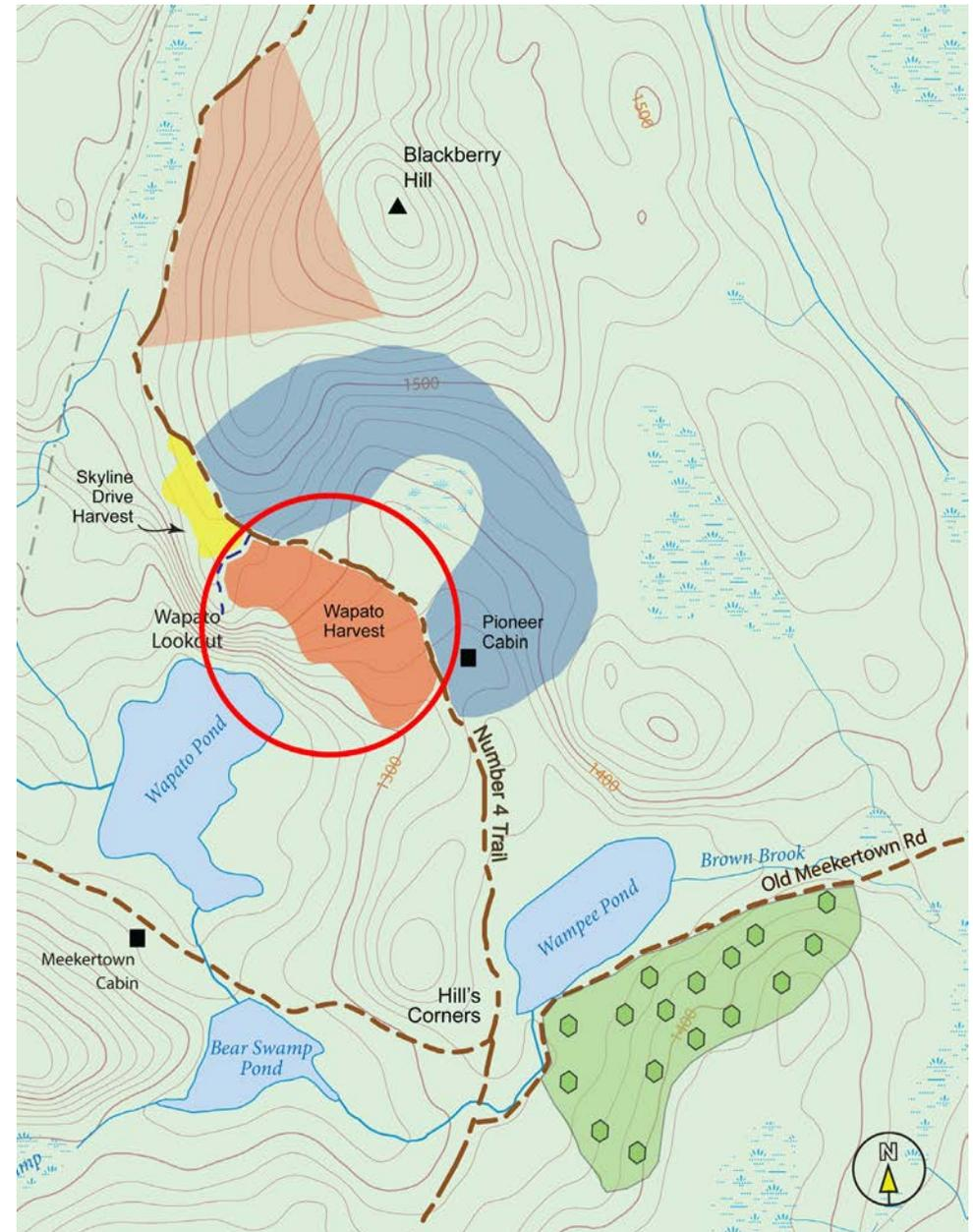

Map of Wapato Lookout Timber Harvest.



The rocky substrate stand. The white oaks growing here are very old, yet are too poorly formed and gnarly to produce much merchantable timber.



Regenerating tulip tree seedlings from the harvest area, emerging from beneath dense mountain laurel.

The third stand comprises a wet lowland sector of 12.2 acres in the center of the parcel. The canopy composition is dramatically different from the previous two stands: dominated overwhelmingly by hemlock, but interspersed with tulip tree, yellow birch, white ash, black cherry, and several black gums. It is notable for being a site frequented by moose, and one of the few places where they have come into contact with tulip trees.

In all, the harvest brought in 120,000 board feet of timber, 66,000 of which was from the 37 acre site alone. In the third stand, a smaller amount was harvested, mostly in the area surrounding the mature tulip trees. The goal here was to provide space for their seedlings to germinate and grow, and to observe whether moose prefer it as a source for browsing. Though it has not been officially documented here, the foresters of GMF have noticed that they do indeed favor the young tulip tree shoots as a food source.

## FOREST MANAGEMENT SITES 5: RED PINE SALVAGE OPERATIONS

### Summary

Red pine plantings at GMF began in 1919, with two small groves installed by Childs and Walcott. This was followed by more extensive plantations in 1938 under Ted's guidance. When these fell victim to the red pine scale in 1999, it prompted a desperate salvage operation to obtain what timber could be harvested before the trees became non-merchantable. This site is distinctive for containing several trees that never succumbed to the insect.

### Access

The site lies at the trailhead for the Tamarack Trail, near the Forestry Office at 201 Windrow Road.

### Location

See included map.

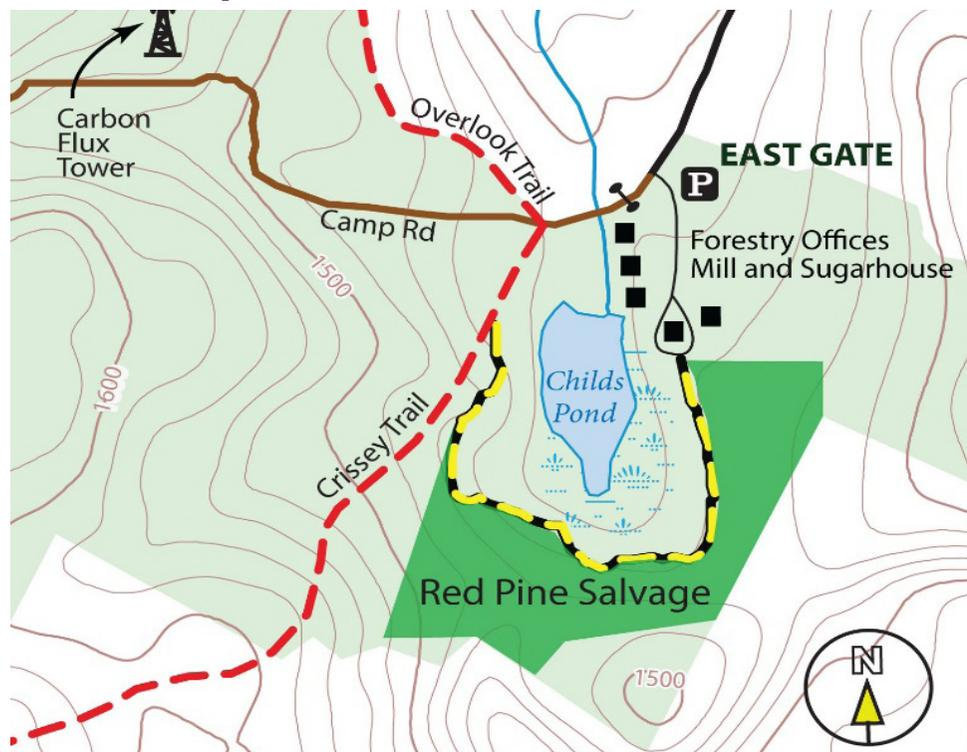

Red Pine Plantation Salvage: N 41°57'59.83"; W 73°13'28.21"

### Nearby or Comparative Sites

The salvage site is just south of the GMF saphouse (Forest Management Site 8). See also the more detailed description of plantations at GMF in general (Forest Management Site 1).

### Description

Red pine was once among the most abundant of the plantation tree species at GMF. Ted Childs and his crew planted most of them in 1938, intrigued by the impressive yield of board feet per acre that the straight trees were known to produce. There was a healthy market for red pine posts then which could be harvested cheaply from thinning the young stands. At this site, two plantations adjacent to one another stood north-south along what is now the start of the Tamarack Interpretive Trail.

The red pine scale (*Matsucoccus resinosa*) is an invasive insect from Asia, thought to have been introduced to the United States during the New York World's Trade Fair in 1939, clinging to exotic trees planted for the event. The larvae hatch from eggs laid on branch axils, and move beneath bark scales to feed on the phloem of the host tree, eventually killing it or making it vulnerable to attack from other pathogens, such as the annosum root rot (*Heterobasidion annosum*). Spread by the wind, the red pine scale reached northwestern Connecticut by the late 1970s, and soon converged on Great Mountain Forest.

A string of several warm winters boosted their populations, and by the summer of 1999 red pine scale spread to nearly all the plantations in the forest. Jody and his forestry crew scrambled to mark as many of the red pine stands as they could while they were still merchantable, which were cut by an independent contractor. This site was no exception to the infestation and harvest, but miraculously, several of the adult red pines never got the scale, and can be seen standing today. A positive consequence of the salvage operation was the scrubland habitat left behind—a haven for passerine birds and small mammals.

Following the salvage operations, Jody and staff planted white pine and European larch in the area. The fast growing larch aided in deterring the white pine weevil from infesting the white pine. A small open patch of these is still growing, on the east side of the trail near the entrance. For the most part, however, the space was quickly overtaken by vigorous pioneer hardwoods, chiefly black birch, which dominate the growing space today.



The red pine salvage operation in progress, summer 1999. The vehicle here is called a harvester, whose long boom can reach a range of trees from a single stationary position, thereby minimizing soil compaction and damage to understory vegetation.



Some of the few remaining red pine at GMF, out of the many plantations which once existed. They stand out high above the surrounding canopy, which mostly established post-salvage efforts.

## FOREST MANAGEMENT SITE 6: LOWLAND WHITE PINE THINNING

### Summary

This site of old field white pine was thinned in the early 1980s to promote the growth of selected individuals. The site has become a haven for several invasive species, who have made the most of the rich soils to grow abundantly around the understory.

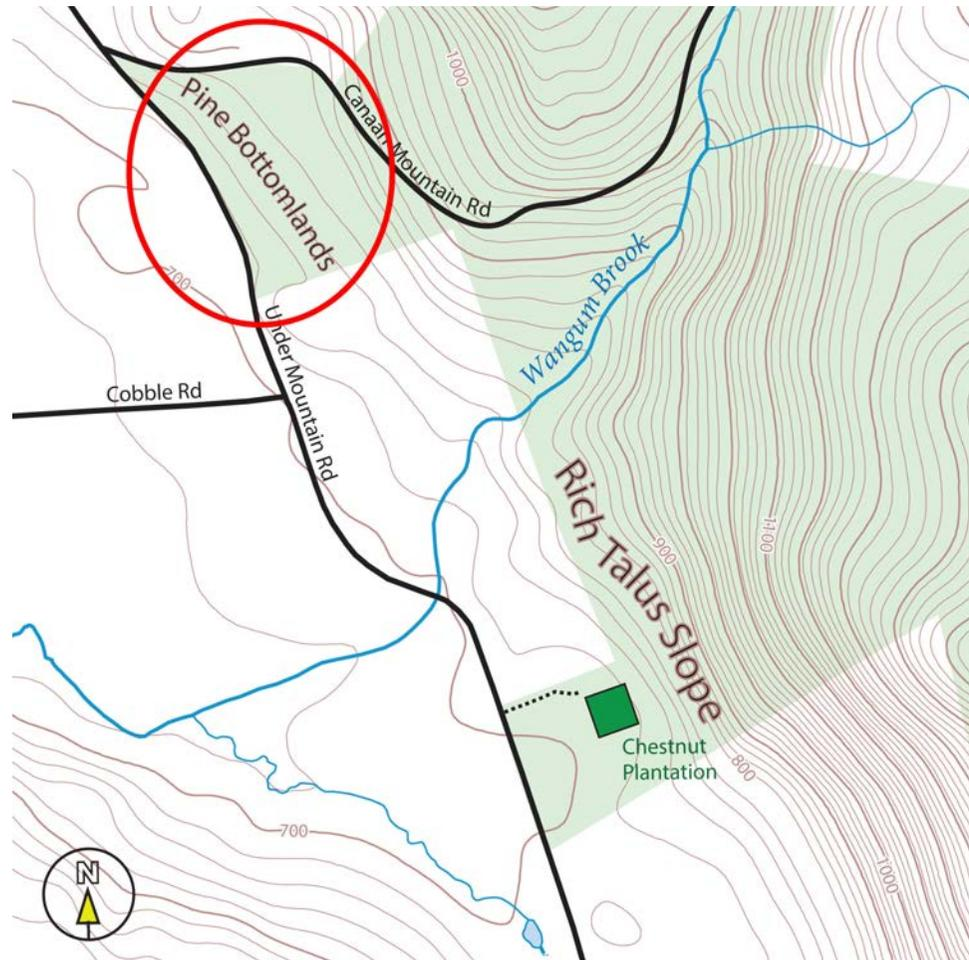

Map of Parking Area and Lowland White Pine.  
Parking Area: N 41°57'00.14"; W 73°17'16.17"  
Lowland White Pine: N 41°56'58.89"; W 73°17'16.03"



View of the attempted white pine planting area in the former red pine plantations along the Tamarack Interpretive Trail. Though a few of the young individuals persist, most did not make it. Darrell Russ, the former GMF head forester, was known to quip at times like these: "the site will grow what it wants to grow!"

**Access**

The site is accessible off of Undermountain Road, heading into the thicket near the intersection with Canaan Mountain Road. Visitors can also park along Canaan Mountain Road, and descend into the site via the katsura plantation.

**Location**

See included map.

**Parking Area**

N 41°57'00.14"

W 73°17'16.17"

**Lowland White Pine**

N 41°56'58.89"

W 73°17'16.03"

**Nearby or Comparative Sites**

The lowland white pine lies just to the north of the rich talus slope (Natural Communities 1) and TACF chestnut plantation (Research Sites 3), and across the street to the south of the Appalachian Forest (Natural Communities 6).

**Description**

This site contains former agricultural land, which regenerated naturally with white pine approximately 70 years ago. Ted Childs bought the parcel as part of the Kellogg purchase in 1941, and proceeded to have several small plantations of chestnut, katsura, dawn redwood, and white fir planted throughout the 1960s and 1970s (see Forest Management 1: Plantations). Abundance of spicebush (*Lindera benzoin*) and a healthy understory wildflower community indicate that the soils here are nutrient rich, underlain as they are with the same blessed limestone as the rich talus slope (Natural Communities 1: Rich Talus Slope).

Over the course of the years of 1980-1984, the GMF crew systematically thinned pines growing in the lowland were by hand. Thinning is a site treatment method that creates more growing space for selected individuals. Self-thinning occurs naturally given enough time, as trees that germinated densely in a site during the stand initiation phase begin to crowd one another, and those without a competitive advantage die

off. By thinning manually, humans are in effect speeding up the process, and are able to exert choice in the remaining trees based on desirable timber (or other) characteristics.

This thinning prescription also included pruning the branches of younger pine stems with hand saws. This ensures that subsequent radial growth will be knot free, and therefore produce a higher quality product.

After each thinning, foresters wait until the remaining trees have grown larger into the released growing space before conducting a harvest, or additional thinning treatments. In the meantime, the understory of this site has unfortunately grown in with hordes of invasive plant species, possibly released themselves by the extra light made available from the thinning treatments. Japanese barberry (*Berberis thunbergii*), a lover of wet environments, is abundant here in the lowland environment along Under Mountain Road. Asiatic bittersweet (*Celastrus orbiculatus*) is a common invasive vine that is now common in the site. Also a lover of mesic woods and edges, it climbs almost cartoonishly by winding around tree trunks of all sizes. Sometimes after removing them, a spiral shape is left embedded in the wood of their host trees if the bittersweet has been growing for a long time. Katsura, from a small adjacent plantation, is also escaping and regenerating in this forest.

Jody plans to return to the site in the future to conduct a harvest of the pine trees, but is concerned about the possibility of the spread of invasives and susceptibility to windthrow. After a thinning, the stem density in the treatment area is, by definition, greatly reduced, which exposes a greater proportion of the stand to the wily whims of the wind. Further harvesting, particularly in this wet area, could heighten the risk of the remaining trees toppling after a particularly heavy storm. Jody and Russell must always dance their dance...



A preponderance of Japanese Barberry, growing below the opened white pine canopy.



Asiatic bittersweet, climbing a mature white pine. The thick, fast growing vines can twist and graft to one another as they ascend.

## FOREST MANAGEMENT SITE 7: WITCH HAZEL HARVEST

### Summary

Witch hazel oil is a non-timber forest product that is harvested at GMF. The process involved opportunistic hand felling along Chattleton Road, and hiring someone with a specialty vehicle to collect to stacked trunks and branches for processing elsewhere.

### Access

This harvest was not conducted in one distinct location, but rather all along either side of Chattleton Road, south of Yale Camp. Look for cut stumps at the bases of witch hazel growing in this region.

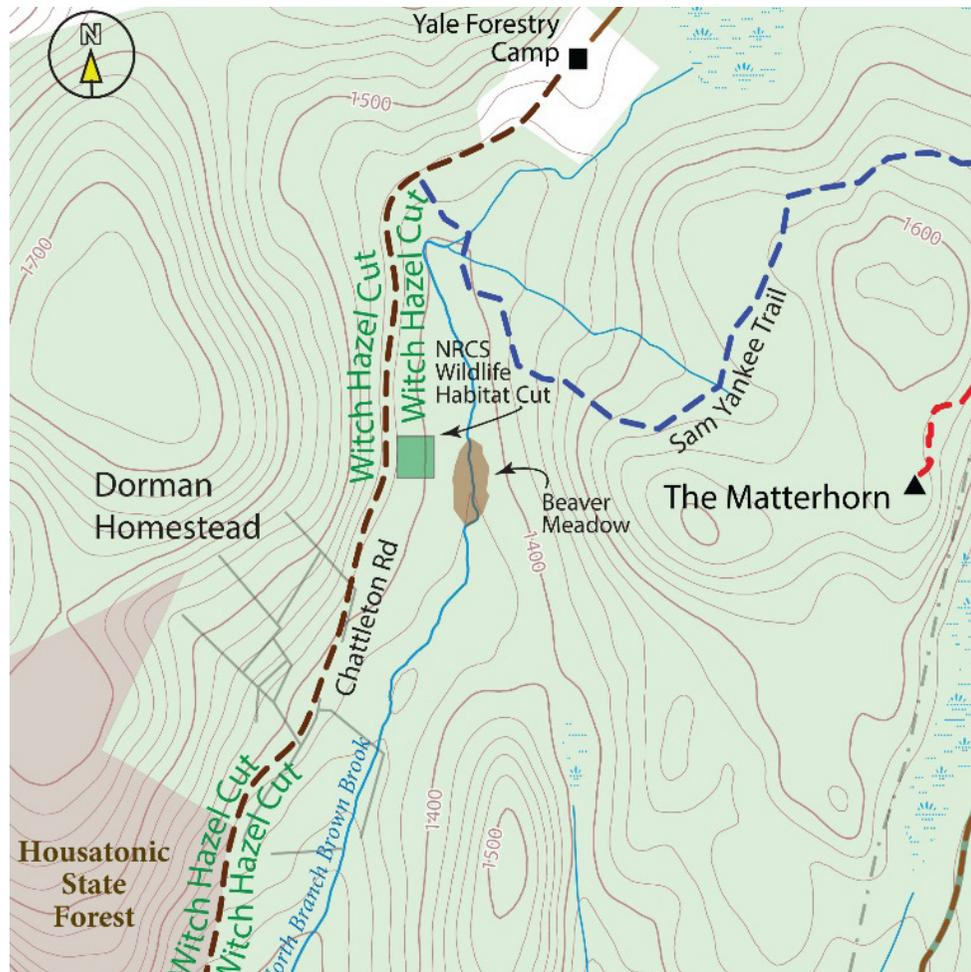

Map of Witch Hazel Harvest location.



Early advertisement of Dickinson's Witch Hazel, circa. 1920.

### Location

*Witch Hazel Harvest, North Boundary*  
N 41°56'43.95"  
W 73°15'53.27"

### Nearby or Comparative Sites

The witch hazel harvest occurred beside the Dorman Homestead Site (Land Use History 6), and the later NRCS Bird Habitat Cut (Forest Management 9).

### Description

Witch hazel is a common understory shrub in the forests of New England, sometimes growing to tree like proportions. The oil extracted from the bark and leaves has various medicinal properties, used mostly for topical wounds and skin care. As it turns out, Connecticut is the #1 global exporter of witch hazel oil and its associated products.

This witch hazel harvest represents GMF's first foray into the lucrative industry. The entire process took place in the fall of 2002, after the leaves were down. The first step involved cutting witch hazel all along

either side of Chattleton Road, south of Yale Camp, and stacking them in piles of about 1-ton each. GMF contracted Eugene Buyak, a proud witch hazel harvest specialist, to cut and gather the piles using his home-made doodlebug. This was an old deuce-n-a-half military truck with a chains added on the back to grapple the stacks of witch hazel. He used this contraption to drag stems to a specialty wood chipper, loaned by Dickinson's Witch Hazel. The chips were then delivered to their processing facility for oil extraction. From there GMF's hard-earned witch hazel made it to the skin and faces of people near and far.

In all, around 2000 tons of witch hazel were removed from along this corridor. In general practice, witch hazel can be harvested from an area on a 10-12 year rotation. The species re-sprouts so vigorously that it is often hard to tell that a plant had ever been cut in the first place. Upon careful inspection, you can see the flat cut stumps at the bases of the fully grown individuals alongside Chattleton Road.

As an unforeseen consequence of this harvest, the doodlebug unearthed many acorns that were buried beneath the duff layer. This facilitated great regeneration of oak trees around the stumps of the cut witch hazel. It is yet another example of a chance factor steering the fate of complexity in forest development.

## Resources

*Dickinson's Witch Hazel Website: <http://www.dickinsonbrands.com/>*

*Beers, David (2010). At work with Bob Haines. Northern Woodlands Magazine, Summer 2010 <http://northernwoodlands.org/articles/article/at-work-with-bob-haines>*



Huge multi-trunked witch hazel along Chattleton Road. This individual resprouted vigorously after the initial cutting.



The coppiced stump of a resprouted witch hazel on Chattleton Road.

## FOREST MANAGEMENT SITE 8: MAPLE SYRUP PRODUCTION

### Summary

This section outlines the history of maple syrup production at GMF. Sugaring operations have been ongoing at Great Mountain Forest for 75 years. Over time various technologies and innovations have been implemented to streamline the process. There have been four incarnations of the GMF saphouse—where sap collected from trees is processed into syrup. In addition to the delicious syrup, sugaring activities provide educational opportunities for community engagement, with folks of all ages.

### Access

The saphouse is adjacent to the Forestry office at 201 Windrow Road. Visitors may park in the parking area by the welcome kiosk. There are areas of currently tapped maple trees along Windrow Road and a sugarbush on Westside Road (green areas, map 1). The primary sugarbush currently in use for gravity tube harvest is just along the Old Meekertown Road, accessed from the southeast quadrant of GMF (green area, map 2).

### Location

See included map.

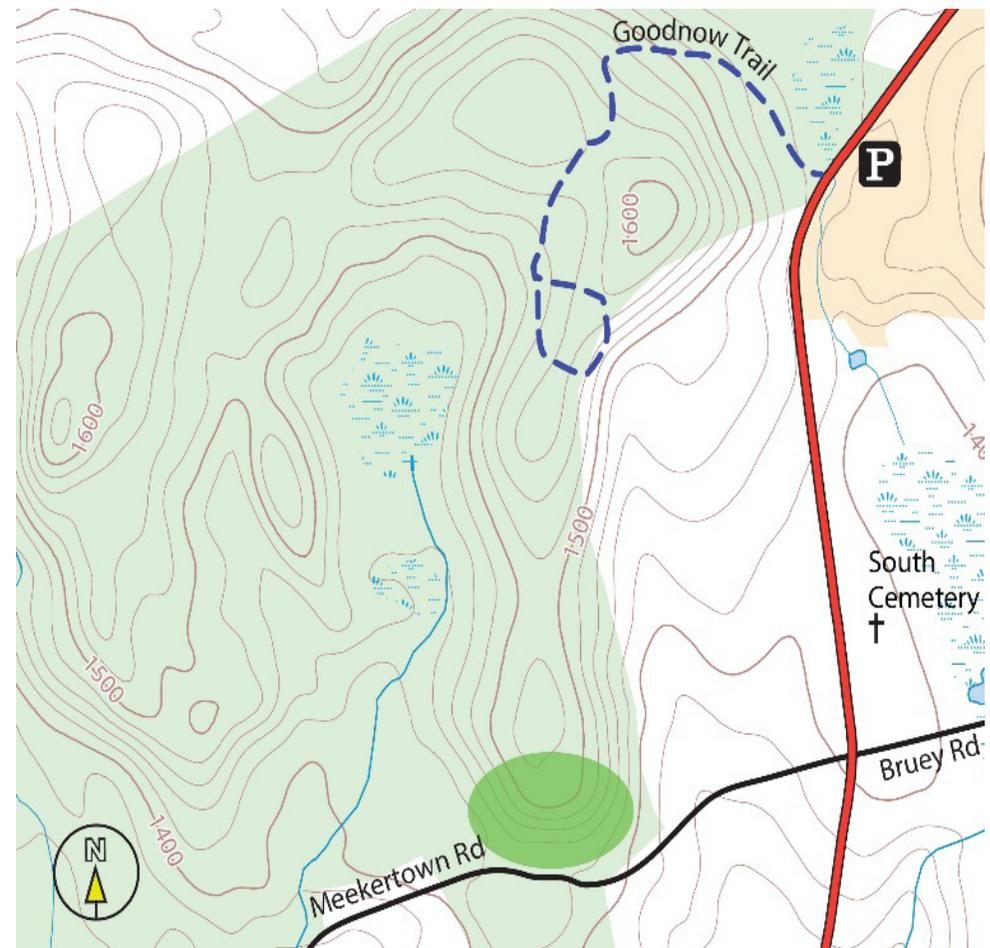
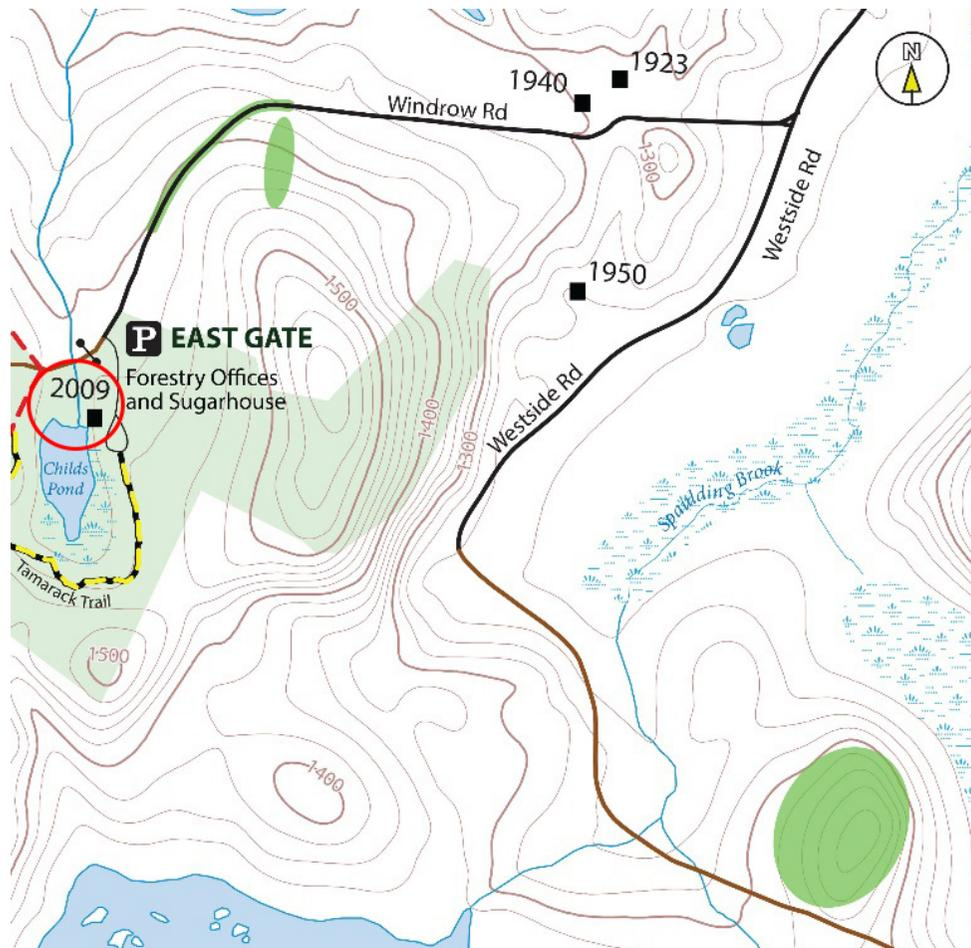

Map of Current Saphouse: N 41°58'03.47"; W 73°13'03.26" and Tapped Maples (in green).

Map of Gravity Tube Harvest Site: N 41°56'30.20"; W 73°12'40.42"

### Nearby or Comparative Sites

The saphouse is near the Forestry Office, the start of the Tamarack Trail, and the Red Pine Salvage Site (Forest Management 6).

### Description

By far, maple syrup is the most beloved of the forest products of GMF. Maple syrup making is a relatively simple process that has been practiced in New England for millenia by Algonquian Indian tribes, many years before the arrival of Europeans. Sap is harvested by drilling short holes into the xylem (water conducting tissue) of sugar maple trees during the earliest part of the spring thaw—a brief period in late February and early March when starch stored in the roots over winter is converted to sugar, and moved upwards through the trunk to provide energy for leaf-out on the outer branches. The collected sap is then boiled to evaporate excess water, leaving behind the viscous sugary substance we know as maple syrup. American Indians accomplished this by filling carved out logs with sap and depositing heated rocks until it was boiled down to the desired consistency. Most private and commercial maple syrup enterprises today use heated evaporators specially designed for that purpose, often with vacuum pumps and reverse osmosis, designed to increase the yields and efficiency. Sugar content in the sap varies according to a number of known and unknown environmental factors, but as a general rule it takes about 40 gallons of sap to produce 1 gallon of syrup.

Retail sugaring operations at GMF have been ongoing continuously since 1940, when Ted Childs established “Coolwater Maple Syrup” (named after the Coolwater family estate) by building a saphouse on Windrow Road. The fledgling enterprise used a small 3’ x 8’ evaporator to heat the collected sap. Initially, GMF staff used a large wagon-mounted tank to transport the gathered sap from the 300 tapped trees to the saphouse. The most valuable workers in this effort were the two horses charged with pulling the wagon on the back and forth journeys, named Chubb #1 and Chubb #2 (respectively). These equine tree sugar couriers served dutifully until 1950, when a second, bigger saphouse was built near Westside Road, and a newly bought truck took over sap collection responsibilities.

The new saphouse, with its larger wood fired evaporator, could process sap into maple syrup at a much faster rate—heating almost 200 gallons of sap an hour (the old evaporator was employed as a pre-heater, to accelerate the proceedings). Productivity increased with the tapping of many new trees, reaching a maximum of 1,950 at one point. An ingenious



A 1973 ad for Buc Wheats cereal, featuring the second GMF saphouse. During shooting, the photographer insisted that he wanted more sap buckets to be visible, which is why additional ones were hung on the tree to the left, even though apple trees are never tapped for sap production.



The faithful Chubbs at work, circa. 1940s.

system to streamline sap collection was devised whereby strategic sap depo containers were established at the tops of steep hills. The sap could then gravity flow down through a labyrinth of aluminum piping to larger holding tanks at the bottom. This incarnation of the saphouse was featured in an advertisement for Buc Wheats cereal, of which maple syrup was apparently a key ingredient (see photo). The second saphouse was used until 1973, when a third house was built near Windrow Road. The fourth (and current) saphouse was built in 2012, constructed completely from white pine and douglas fir timber harvested at GMF. It sits proudly next to the Forestry office at 201 Windrow Road, at the eastern boundary of the forest.

Today, sugarers at GMF produce around 100 gallons of maple syrup annually for retail consumption. Many of the 450 currently tapped trees are the same ones that have been used for the past 60 years. While the traditional bucket method is still used on about 100 of the tapped trees, most of the collection is now collected via gravity-fed tubing. There are several sugarbush management areas in Great Mountain Forest—Groves



Tapped trees using the bucket method. Unlike the gravity tube, these must be individually emptied on a regular basis after they fill during the heat of the day.

of sugar maples are carefully thinned to produce stands of maximum sap production once they have reached the appropriate size of 15-inches DBH. These may be utilized one day in future sap harvests.

Aside from the syrup itself, sugaring operations at GMF have yielded substantial informational outputs. A detailed saphouse diary has been kept for the past 70 years, chronicling the sap output, sugar content, and syrup production levels throughout each sugaring season, as well as observations of phenological phenomena such as the return date of various migratory birds, or the first budding of particular tree species. Taken together, these records provide a wealth of information on the timing and fluctuations of many forest phenomena across a huge period of time. But perhaps the most important aspect of the sugaring operation is its value as an educational resource for the community. GMF hosts maple syrup workshops and outreach programs to demonstrate all stages of the process from tapping to tasting throughout the season.



Head forester Jody Bronson, posing by the current saphouse woodshed. The evaporator used to turn sap into syrup is heated exclusively by firewood harvested and seasoned at GMF.



The modern day saphouse in action.



The modern day Jody in action. The wood-fired evaporator heats up the sap in several stages to speed up the process.



GMF sugarbush along Old Meekertown Road, tapped with gravity tubes. The sap drains directly from the trees into a single shared basin, thereby saving much labor in the collection process.



A demonstration sugarbush management area along Chatleton Road. Once the trees have grown to sufficient size, they will be recruited for future sap harvests.

## FOREST MANAGEMENT 9: NRCS BIRD HABITAT CUT

### Summary

This 2013 cut was conducted to create habitat for a more diverse assemblage of bird species. Through considering canopy structure and the retention of certain features, the forested environment can be tailored to promote diversity and resilience in forest bird populations.

### Access

The site sits along the east side of the old Chattleton Road, a short walk south from the Yale Camp.

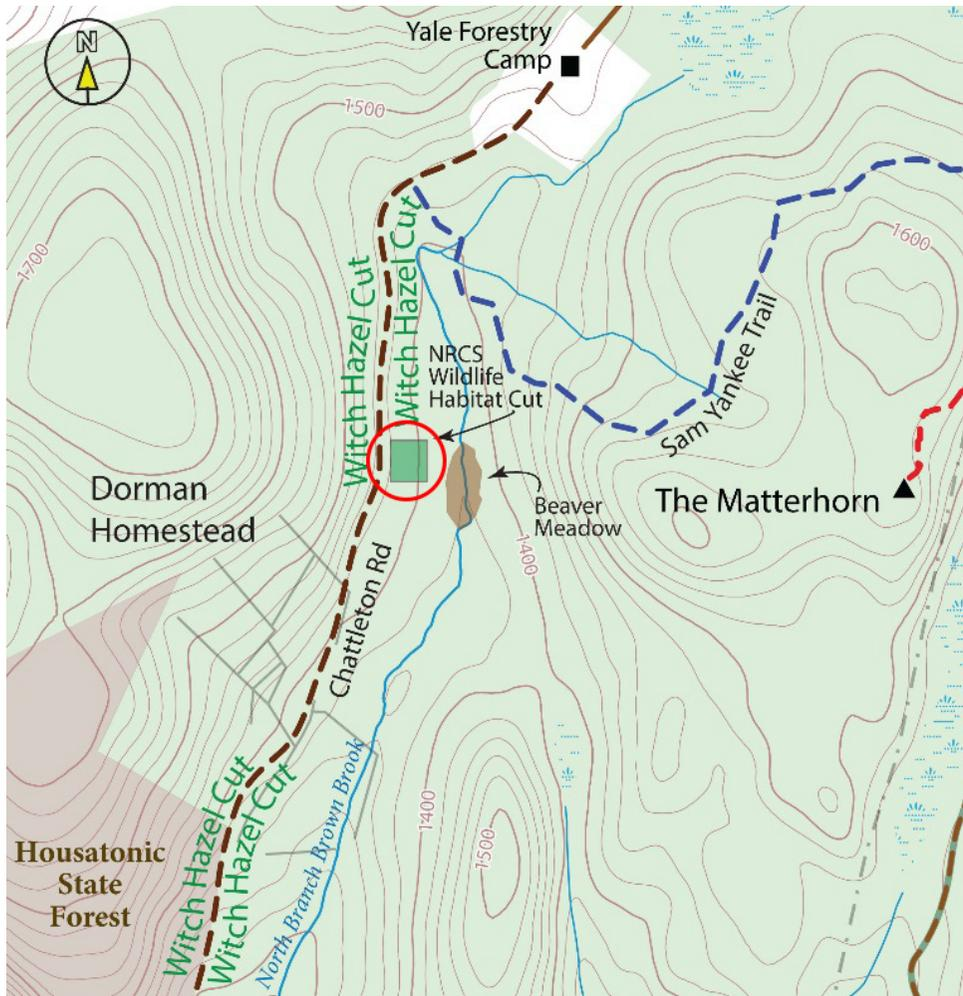

Map of Bird Habitat: 41°56'28.65" N; 73°15'56.00" W

### Location

See included map.

### Bird Habitat

41°56'28.65" N

73°15'56.00" W

### Nearby or Comparative Sites

This site occurs in a hub of forest activity directly west of the beaver meadow (Natural Communities 9), northeast and southeast of the 2004 witch hazel harvest (Forest Management 7), and northeast of the Dorman homestead (Land Use History 6).

### Description

Silvicultural goals can run the gamut from economic gain, to aesthetic virtue, to habitat creation. Through thoughtful planning and careful execution, diverse objectives may be achieved. Oftentimes, the primary intention is to conduct a profitable harvest that maintains the health and productivity of the forest. Creating wildlife habitat is often a matter of secondary importance (however diligently considered). The chief priority of the next two sites, however, was opening the canopy to promote populations of specific animals. Such cutting edge silviculture is becoming more common in conservation organizations throughout the globe.

In 2013, GMF received a grant from the Natural Resources Conservation Service (NRCS: an agency in the USDA) to clear a section of open forest habitat for passerine (perching) songbirds. Birds as a taxonomic group are a good example of adaptive radiation, wherein diversity increases greatly following the creation of a new set of resources in an environment, or the evolution of some novel feature. In this case, the advent of flight allowed birds to evolve into a diverse suite of hitherto unoccupied niches. Among forest birds, individual species are each specialized (by varying degrees) to different canopy structures. By creating a mosaic of different stands, forests can be managed to provide habitat for a much greater diversity of bird species than would be present otherwise.

Complex canopy structure is the chief consideration to meet the habitat requirements of as many bird species as possible. This means maintaining patches of different age classes within the wider, more mature forest. This small several-acre cut at GMF is open enough to promote the regeneration of a new cohort of trees. Adjacent to the east is the beaver



A cut red maple stump on site, which is re-sprouting. Tree coppicing is a way for certain species to regenerate quickly from an already mature root system.



View of the site, just two years after harvesting. In that time, the understory has grown back in great swaths of hay scented fern, which is notorious for its ability to impede tree seedling regeneration for many years.

meadow, with its own distinct wetland structure. Both of these sites are relatively small patches, nestled strategically within the broader matrix forest of GMF. Structure is also defined vertically, referring to the niches in canopy position that are available. Though mostly open now, the site will receive additional treatments in years to come to ensure that the developing canopy, mid-story, understory, and ground layers are each represented with the appropriate vegetation.

The site retains a few tall trees that will grow to have large diameters. Tall trees provide nesting sites for woodland raptors, such as the Cooper's hawk (*Accipiter cooperii*). Many of the cut branches of removed trees were left on the ground as coarse woody debris, where they are used as habitat for ground nesting birds such as the ruffed grouse (*Bonasa umbellus*) and wild turkey (*Meleagris gallopavo*). Though none are located on the current site, it is common practice for harvests at GMF to leave snags (standing dead trees) as crucial habitat for woodpecker species and other birds that nest in them.

This cut was performed with hand felling techniques and a skidder to transport logs to the road. Much of the cut red maple was processed as firewood for use at GMF. As the final stage of the harvest, all invasive Japanese barberry in the site was treated with a chemical herbicide. Though many bird species will sometimes eat the berries of invasive barberry and bush honeysuckle, they provide only minimal nutrition, and compete vigorously for growing space with more beneficial shrubs.

Though still in the early stages of development, this site is a key demonstration of GMF's commitment to practicing conservation forestry. Repeat treatments will be performed at regular intervals over the next century to help maximize bird diversity in the area.

#### Resources

*Audubon Society, 2011. Silviculture with Birds in Mind: Options for Integrating Timber and Songbird Habitat Management in Northern Hardwood Stands in Vermont.*  
[http://ct.audubon.org/sites/default/files/documents/silviculture-options\\_0.pdf](http://ct.audubon.org/sites/default/files/documents/silviculture-options_0.pdf)

## FOREST MANAGEMENT SITES 10: NEW ENGLAND COTTONTAIL RABBIT HABITAT

### Summary

This clear cut was performed during the winter of 2015 to create habitat for the New England cottontail, which has become rare throughout the majority of its historical range. The 18 acre area will regenerate into dense, early successional forest which the rabbits require for foraging and protection from predators. Populations will be monitored to determine the success of these efforts.

### Access

The New England cottontail habitat is easily accessible just off of the south side of Wangum Road. The information kiosk at its northern edge is an easy walk from the Mountain House.

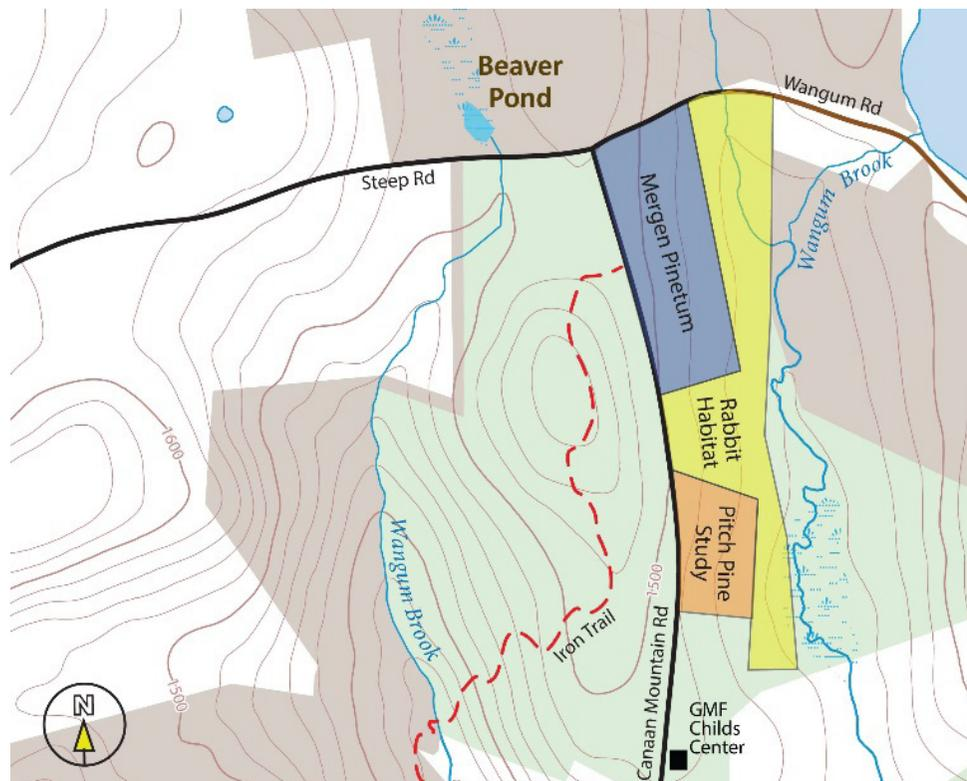

Map of Rabbitat: 41°58'28.10" N; 73°16'12.04" W

### Location

See included map.

### Rabbitat

41°58'28.10" N

73°16'12.04" W

### Nearby or Comparative Sites

The eastern cottontail habitat restoration area sits adjacent to the Mergen Pinetum (Research Sites 4), the Pitch Pine Study Site (Research Site 5), and across the street from the Stone Man Trail (Geologic Site 7).

### Description

The goal of this cut was to create habitat for New England cottontail rabbits (*Sylvilagus transitionalis*). The species once ranged from New York state, east across the Hudson River to southern Maine and New Hampshire. From the late 1800s through the 1960s, the closely related eastern cottontail (*S. floridanus*) was systematically introduced across much of this region as a source of game for hunters. They eventually replaced the native New England cottontails, who today exist in just a few scattered populations in Maine, New Hampshire, Massachusetts, eastern New York state, and Connecticut. The species was listed as vulnerable in 1996 by the International Union for the Conservation of Nature (IUCN), and is currently a candidate for endangered status.

Unlike the eastern cottontail which is more of a habitat generalist, New England cottontails are restricted to early successional forests, where the dense thickets of young, regenerating trees enable them to evade predators, while providing ample browsing opportunity. However, for the last hundred years most forests in the region have grown to a mature state from abandoned agricultural land, or else been converted wholly to development projects, leaving very little of the scrubland that the species needs in order to thrive.

One of the last major population pockets of the New England cottontail rabbit is in Litchfield county, Connecticut, prompting special efforts to focus habitat creation in the region. In 2013, the Connecticut State Department of Energy and Environmental Protection (DEEP) conducted a 59 acre clearcut on part of its state land holdings near Goshen. After identifying the presence of a small population of New England cottontails near Wangum Road in Norfolk, DEEP collaborated with the



Southward facing view into the cottontail habitat from Wangum Road. The kiosk provides information about the New England cottontail, and the motivations behind clearcutting the area (lest passerby think it was for selfish reasons).

Great Mountain Forest to create an 18 acre early successional habitat parcel in the winter of 2014. The area was completely clear cut of all trees greater than 3 inches in diameter, except for some stray apple and hawthorne trees which offer excellent wildlife value. Brush was stacked into piles throughout the area to provide habitat cover for the next few years, while waiting for young trees sprout into a dense thicket. Wildlife biologists from the New England Cottontail Initiative will monitor the area for signs of new rabbits. In the meantime, the opened area makes great habitat for ground nesting birds like turkeys and ruffed grouse. It is well to remember that conservation efforts aimed at a particular species can have positive consequences for other organisms.



Heaps of brush like this one were piled strategically all around the cut over area. They will hopefully provide shelter for the rabbits until the surrounding forest has developed.

## Resources

*New England Cottontail Initiative Website:* <http://newenglandcottontail.org/>.

Wood, Wiley. "Connecticut Biologists Create Habitat for the Endangered New England Cottontail." *Norfolk Now*. 02 June 2013. Web. 21 Aug. 2015. <http://www.nornow.org/2013/06/02/its-only-natural/>.

Wood, Wiley. "Landowners Make Clear-Cuts To Benefit Rare Cottontail Rabbit." *Norfolk Now*. 27 Feb. 2015. Web. 21 Aug. 2015. <http://www.nornow.org/2015/02/27/landowners-make-clear-cuts-benefit-rare-cottontail-rabbit/>.



## RESEARCH SITES

PAST AND PRESENT

Ever since the early days of leadership by Ted Childs, Great Mountain Forest has been a major site of ecological research, with some 80+ published studies and articles coming from data collected by researchers throughout the forest. Studies cover a wide range of topics, including wildlife analyses, forest development and growth modeling, tree genetics, soil science, and meteorology. Promoting research in the forest is one of the major outreach goals of GMF, and staff members frequently help collaborate on projects.

Research in the forest also includes more informal, unpublished data collection efforts through the day to day management operations. GMF forester Russell Russ collects daily weather data from the Norfolk station established by Ted Childs by Jody Bronson keeps detailed records from all timber harvesting, and collects wildlife reports from hunters on the property. The saphouse journal goes back more than sixty years, and records annual sap production and sugar content, as well as phenological data for plants and animals throughout the course of the sapping season.

What follows are six sites of past and current research projects where there are interesting features and lasting legacies to observe. For a more complete annotated bibliography of research conducted at Great Mountain Forest, please see Appendix II.

# RESEARCH SITE 1: MOOSE EXCLOSURES

## Summary

A recently established study to investigate the impact of moose browsing on the development of understory vegetation. Such work is pioneering in GMF, where moose have only recently arrived.

## Access

The study plots are just off of the Number 4 Trail, about 1/2 mile south of the intersection with Old Meekertown rd. near the southernmost GMF boundary. Look for the clearcut site on the west side of the road.

## Location

See included map.

Great Mountain Forest																									
Hunter Name:		Deer Sightings			Deer Harvested		Other Wildlife Sightings Please record numbers of each seen. For those not listed record animal in "Other"							Conditions (See legend below)											
Month / Year:	Hours Hunted	Hours	Zone	Buck	Doe	Fawn	Points	Weight	Weight	Bear	Bobcat	Coyote	Fisher	Fox	Grouse	Moose	Rabbit	Raccoon	Turkey	Other	Precip.	Wind	Moon Phase	Mast	Beechnuts
1	am / pm																								
2	am / pm																								
3	am / pm																								
4	am / pm																								
5	am / pm																								
6	am / pm																								
7	am / pm																								
8	am / pm																								
9	am / pm																								
10	am / pm																								
11	am / pm																								
12	am / pm																								
13	am / pm																								
14	am / pm																								
15	am / pm																								
16	am / pm																								
17	am / pm																								
18	am / pm																								
19	am / pm																								
20	am / pm																								
21	am / pm																								
22	am / pm																								
23	am / pm																								
24	am / pm																								
25	am / pm																								
26	am / pm																								
27	am / pm																								
28	am / pm																								
29	am / pm																								
30	am / pm																								
31	am / pm																								

Legend: For Wind, Acorns, and Beechnuts use L for light, M for Moderate, and H for heavy.  
For precipitation use CL for clear, LR for light rain, MR for moderate rain, HR for heavy rain, and LS, MS, HS for snow conditions.  
For Moon Phase use NW for new, FQ for first quarter, FL for full, and TQ for third quarter.

The wildlife sighting sheet given to hunters at GMF. By engaging with GMF's diverse visitor base, valuable information can be collected about the health and diversity of the forest.

## Moose Exclosures

N 41° 55' 11.142"

W -71° 15' 7.7454

## Description

This ongoing study was established in 2010 as a collaboration between researchers from Highstead and the University of Massachusetts at Amherst. The purpose is to study the impact of moose herbivory on the regeneration of tree seedlings following the opening of light gaps in the canopy. It has been long documented that interference from mammals can significantly delay or alter the dynamics of forest regeneration, though the impact of Moose in their new Connecticut environment has yet to be established.

The study sites are established within a 4 acre clearcut site that was conducted specifically for the purposes of this research. GMF harvested the trees, which primarily consisted of white pine and oak that were later used

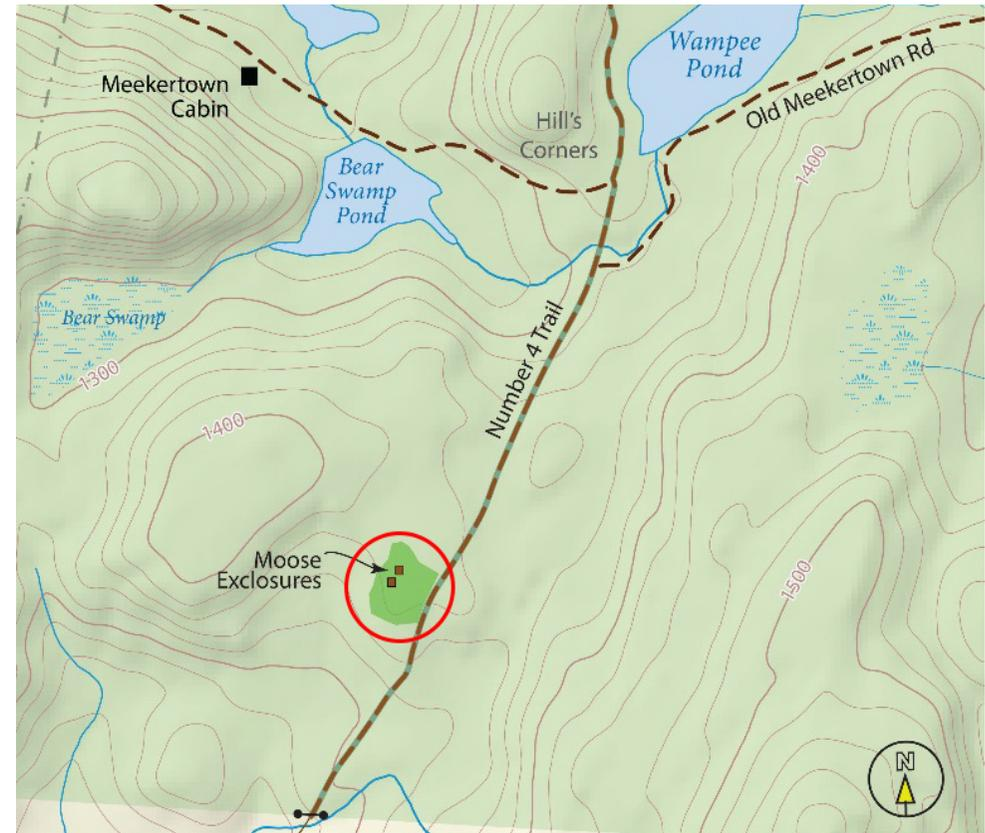

Location of Moose Exclosure site.

to build the 2012 GMF saphouse (see Forest Management 8).

The site consists of three equal-sized experimental plots Plot 1 is surrounded by tall fencing that is suspended slightly above the ground, while Plot 2 is surrounded by fencing that goes all the way down. This is meant to control for differences in herbivory by non-moose animal species who are able to fit beneath the fencing gap, such as rabbits and small deer. Plot 3 is a designated control plot area, marked on all sides by metal posts but with no fencing to impede access by animals.

Even just a few years into the establishment of the study, there are already stark differences between the enclosed areas and the moose exposed clearcut. Among the common tree species present, (red maple, black cherry, red oak, and beech), there is markedly higher growth and abundance. Outside of the exclosures, trees are frequently shrub-like and multi-trunked, the result of vigorous re-sprouting following grazing. The deer exclusion areas also feature a much lower ground cover density of hay-scented fern and blackberry, species that can impede tree seedling regeneration for extended periods of time if given the opportunity to establish a foothold.

Besides being notable for its value as an important research location, the moose exclosure study site is also an excellent place for birdwatching. Keep an eye out for the eastern towhee, catbirds, yellow-rumped warblers, and other forest edge species.

#### **Researcher Contact Information**

Dr. Stephen DeStefano, Research Professor and USGS Massachusetts  
Cooperative Fish and Wildlife Research Unit Leader  
sdestef@nrc.umass.edu

Dr. Edward Faison, Highstead Ecologist  
efaison@highstead.net



**View from the outside of the complete moose exclosure. Even several years into this long term study, there are already stark differences in vegetation where the moose are excluded from browsing.**

## RESEARCH SITE 2: FOREST SUCCESSION DYNAMICS STUDY

### Summary

Established in 1967, this is one of the longest running studies following forest succession in eastern North America.

### Access

The Thick and Thin Till sites are both off of Chrissey Trail to the south. From Chattleton Rd, turn onto Camp Rd at Potter's Corners, turn right onto the Number 4 Trail, and then left onto Chrissey Trail. The Outwash Site is just off of Gamefield Rd, a private road off of Windrow Rd., east of the GMF Forestry office. Please get permission from the GMF staff beforehand if you are planning on using a motorized vehicle to access any of these sites.

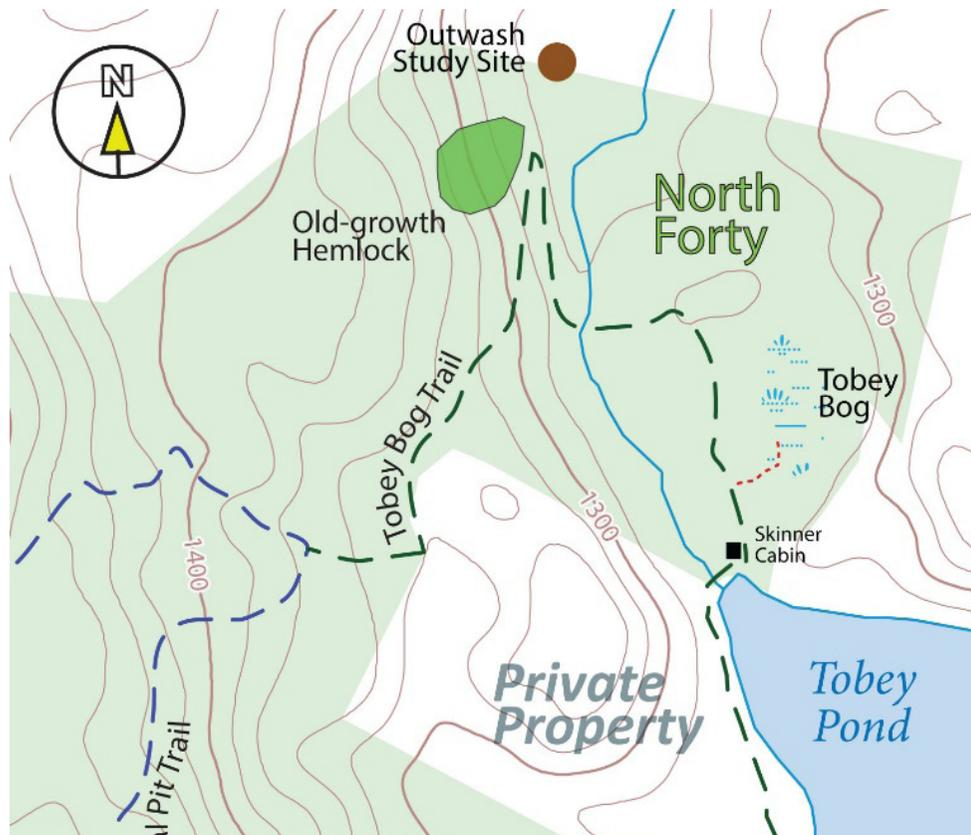

Outwash Site 41°58'55.40" N; 73°13'41.69" W

### Location

*Outwash Site*

41°58'55.40" N

73°13'41.69" W

### Nearby or Comparative Sites

The research on forest succession nicely complements the PhD studies by Matt Kely (see Research Bibliography, Appendix II), providing an earlier snapshot of the mature canopy dynamics that he details.

### Description

This ongoing study was established by former Yale F&ES silviculture professor David M. Smith in 1967. He set up cleared strip plots (80 feet wide) in three different microenvironments to monitor how the tree species

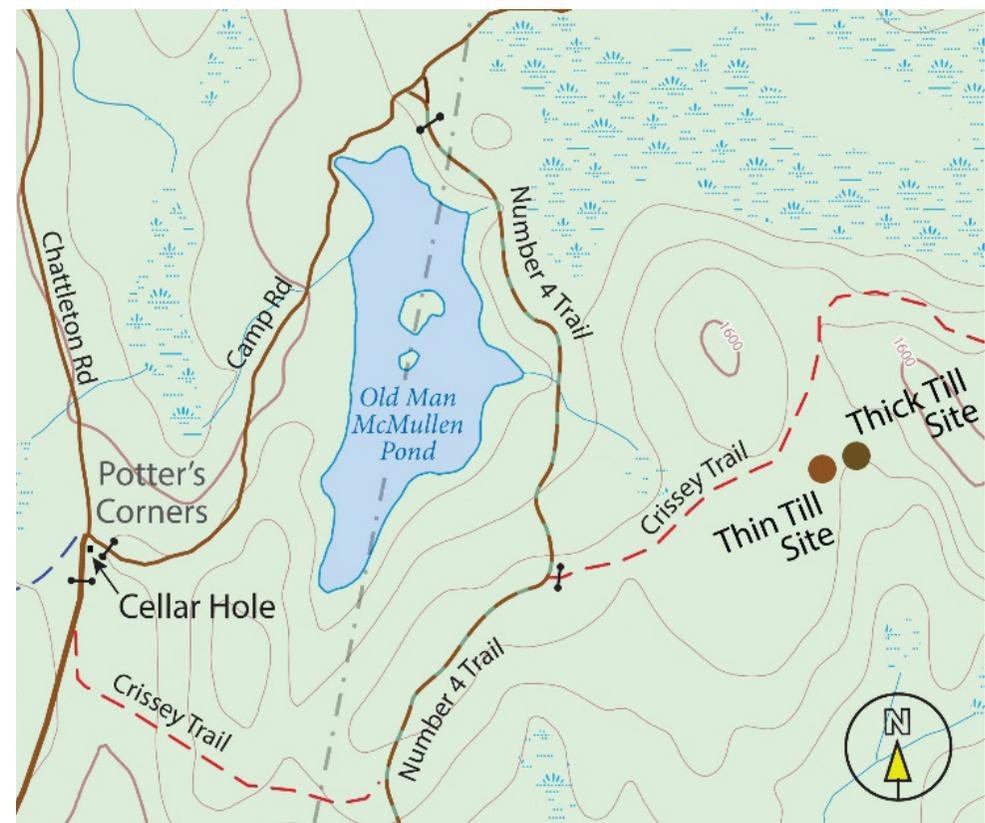

Thick Till Site 41°57'25.08" N; 73°14'37.73" W

Thin Till Site 41°57'24.64" N; 73°14'39.04" W



The Thick Till Site, shortly after establishment in 1969. For several years at the beginning of the study, a dense ground story layer inhibited tree seedlings from establishing.

composition and structure would develop in each over time. The sites all experience similar climactic conditions, but have different underlying substrates. The thin till and thick till sites have unsorted rocky soils of gneiss and schist origin—ground up and dumped in a heap by glacial activity. They differ only with regard to average depth of soil to bedrock (1.5 feet and 3.0 feet, respectively). The outwash site contains sand and gravel soils whose particles have been sifted and sorted by running water following the retreat of the glacier. Trees of all species were measured for height and diameter at periodic intervals, as well as mortality of individuals. In this way, the growth and composition of the forest in these plots have been charted continuously for almost 50 years.

These sites have been the source of two published papers so far, with a third currently in preparation. Smith and Ashton (1993) describes the development of the forest canopy over the first 18 years of the study at GMF, as well as counterpart plots located in the Yale-Toumey Forest in New Hampshire. All showed similar initial development, becoming dominated early on by dense tangles of blackberry (*Rubus* sp.) and thick stands of pin cherry (*Prunus pensylvanica*), an early pioneer tree species that quickly dominated the initial canopy. Gradually, all plots increased in



The Thin Till Site in 1969. David Smith put fencing around all the plots, to prevent deer herbivory as a confounding factor in the study.

abundance of paper birch (*Betula papyrifera*), and later black birch (*B. nigra*) in the midstory, with some red oaks (*Quercus rubra*) and hemlocks (*Tsuga canadensis*) beginning to establish in the understory. The initial results show a forest beginning to develop different strata based on dispersal mechanism and relative shade tolerance of the tree species present.

The second paper, Liptzin and Ashton (1999), charts forest development in the thick and thin till sites after 28 years of growth, comparing canopy structure between the years 1986 and 1995. The stratification of the stands continued during this period, with pin cherry and paper birch still the dominant canopy species, and a mid-story of ascendant black birch and black cherry. By this point in the forest development, the available growing space has been taken up, with increased mortality among out-competed trees. As a consequence, both plots showed a reduction in the number of trees over time, but an overall increase in average basal area, as remaining trees grew larger to take up the newly available light made available by their dying neighbor trees. Differences between the plots also began to emerge during this time period, with smaller diameter trees and a greater abundance of red oak in the thin till site, and more black and yellow birch on the thick till site.



The Thick Till Site, summer 2015. The stands have grown into more mature black birch dominated mixtures, with an ascending midstory of shade tolerant beech and hemlock.

Yale FES doctoral student Mark Ashton in one of the strip cuts, September 1987. In less than 25 years, the forest has already grown back into a densely crowded overstory.

The paper currently under preparation aims to compare the growth patterns of all three plots from their inception to the present day. Preliminary data collected in 2015 shows a dramatic shift in canopy composition, with all the pioneer pin cherry and paper birch completely absent, greater numbers of red oak entering the black birch canopy, and more shade tolerant hemlock and American beech moving into the midstory.

Though long term forest succession studies of this kind have become more common, very few have been running as long as this study. New data collected from these sites will continue to shed light on succession dynamics in the GMF region.

#### Researcher Contact Information

Daniel Liptzin, Researcher, University of California, Berkeley  
liptzin@nature.berkeley.edu

Mark Ashton, Professor of Silviculture, Yale School of Forestry and Environmental Studies  
mark.ashton@yale.edu

Yoni Glogower, Master of Forestry Candidate, Yale School of Forestry and Environmental Studies  
jonathan.glogower@yale.edu

#### Resources

*Liptzin, D., and P.M.S. Ashton (1999) Early-successional dynamics of single-aged mixed hardwood stands in a southern New England forest, USA. Forest Ecology and Management 116: 141-150.*

*Smith, D.M., and P.M.S. Ashton (1993). Early dominance of pioneer hardwood after clearcutting and removal of advanced regeneration. Northern Journal of Applied Forestry 10: 14-19*

## RESEARCH SITE 3: AMERICAN CHESTNUT PLANTATION

### Summary

Once an abundant species in the eastern United States, the American chestnut has been decimated throughout its natural range by the chestnut blight, introduced in New York in 1904. The American Chestnut Foundation's plantation at GMF is part of a large, region-wide effort to create disease-resistant hybrids of the species

### Access

The Chestnut Plantation rests at the east facing foot of Great Mountain (formerly Canaan Mountain), set back hidden from the road by a grassy meadow and a few relict Christmas tree plantations, (now grown to un-

merchantable heights). A mowed pathway running east-west at the north end of the meadow provides the most direct car access to the site, though visitors may also park in the grass along Under Mountain Road.

### Location

See included map.

### *Chestnut Plantation*

N 41°56'31.99"

W 73°16'58.26"

### Nearby or Comparative Sites

As shown on the locator map, the Chestnut Plantation is near a number of unique sites, sitting as it does in the only small pocket of the forest whose elevation dips under 1000 feet above sea level. It is immediately adjacent to the Rich Talus Slope site (Natural Communities 6), and close to the south of the lowland white pine thinning area (Forest Management 6), the Katsura Plantation (Forest Management 1), and the Appalachian Forest pocket (Natural Communities 8).

### Description

When the chestnut blight swept through the northeast in the 1910's, it wiped out virtually all the adult trees in the region (see Species of Interest). At GMF, two separate salvage operations were conducted, in 1918 and in 1938, to retrieve what little merchantable timber could be found in the dead and dying trunks. Since that time, there have been several attempts at GMF to re-establish the species. In 1947, the Connecticut Ag. Station, led by pathologist Arthur Graves, received permission from Ted Childs to put in a plantation of hybrid American/Chinese chestnut crosses down by Robbin's Pitch, just north of Pothole Falls in the southwestern corner of the forest. The US Forest Service monitored and maintained the project until 1978, when they discontinued their efforts because all the trees had died. Concurrently, Ted himself established several chestnut plantations of his own in 1962; one group across the street from the Mountain House, another near the corner of Canaan Mountain Road and Mountain Road, and a third down by the lowland white pine on Under Mountain Road. These, too, succumbed to the blight after several years, and no trace of them remains today.

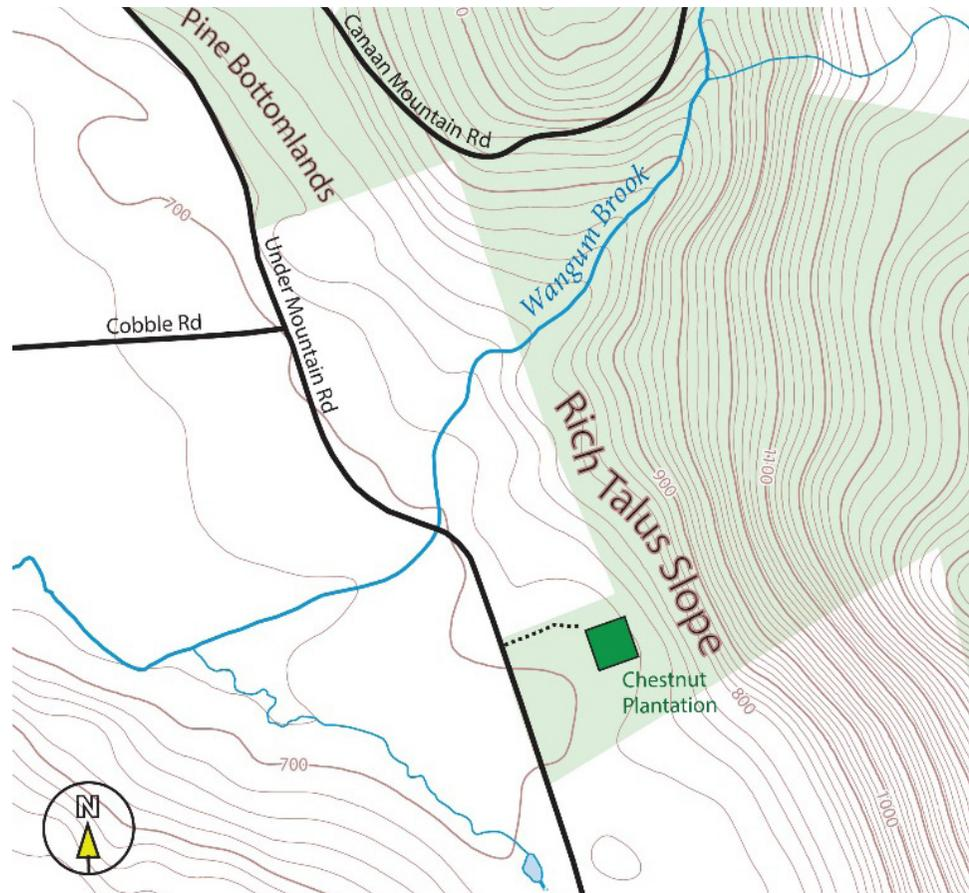

Map of American Chestnut Plantation.

Following these failed attempts, it was not until 2007 that the current chestnut plantation was established at GMF. The American Chestnut Foundation (TACF) has been working since 1983 to breed trees that are resistant to the blight, but still retain most of the genetics and morphological characteristics of the original American chestnut. Since chestnuts as a genus are wind pollinated, any two individuals can be bred to one another by manually transporting selected pollen from one individual to selected flowers of others. By this process, the foundation bred hybrids of Chinese and American chestnut, and then backcrossed these with original American chestnuts. After three backcross generations, the resultant offspring are individuals that are 15/16 (~94%) American chestnut (the BC3 generation). Most of the BC3's are resistant to the blight, however, to ensure that they breed true to this trait, they are bred with one another for an additional two generations (the BC3F2 and BC3F3 generations, respectively). At each of these stages, only resistant individuals are selected to produce the progeny of the succeeding generation.

As a non-profit organization, the success of TACF depends upon private landowners and organizations who volunteer plots of their land for plantations. Facilitated by a strong pre-existing friendship with TACF collaborator Woods Sinclair, GMF became such a partner in 2007. The current 2 acre site was formerly and old Christmas tree plantation, which they cleared and mowed prior to planting. The site was chosen because it has all the required, favorable characteristics: suitable pH, good drainage, easy access from the road, ample sunlight from the south-western exposure, and ample water availability from the farm across the street.

The trees in this plantation are all members of the first BC3 generation—the first batch of hybrid trees that share 96% of the same genetic material as native American chestnut trees. Those that are deemed resistant to the blight will be crossed with other BC3's to produce a generation that will breed true for resistance. To prepare the site for planting, Woods brush-hogged the entire site and installed a solar-panel electric fence to exclude deer. They planted rows approximately 6 feet apart, with trees about every 3 feet within rows, using seeds and saplings provided by the Burlington, VT branch of TACF. Students from the local high school came to help with the planting efforts, as part of their vocational agriculture science and technology program. Proper tree establishment involved first sifting and mixing the soil substrate at each planting site, digging the holes, placing the nut or seedling, and finally staking the new initiates with Blue-X tree shelters to protect them from



Volunteers planting chestnut seedlings at the new plantation. Note the blue tree shelters, used to protect the young trees from herbivory.



Woods Sinclair (blue shirt, rear) with planting volunteers from the local high school.

marauding herbivorous woodland creatures.

TACF staff and their volunteers planted several new rows of trees each year from 2007 to 2012. Since establishment, Woods, with assistance from his student volunteers, has kept an annual fall inventory of growth and mortality. This information is used by TACF to determine protocols for their various breeding lines, in conjunction with similar studies of their many other plantations. A special account exists to pay for an intern to maintain the orchard throughout the rest of the growing season.

The future of the GMF chestnut plantation is currently uncertain. TACF is currently conducting test plantings of their first BC3F3 generation seedlings, but only time will tell if they prove to be as resistant to the blight as expected.

#### Researcher Contacts

Ellery Woods Sinclair  
wml61@comcast.net

Dr. Leila Pinchot, U.S. Forest Service  
corneliapinchot@fs.fed.us

#### Resources

*TACF official website:* <http://www.acf.org/>

*Listing for the GMF orchard in the Connecticut chapter of TACF:* <http://ctacf.org/ct-plantings/great-mountain-forest-orchard/>

*Freinkel, Susan (2007) American Chestnut: The Life, Death, and Rebirth of the Perfect Tree. University of California Press, Berkeley and Los Angeles.*



The chestnut plantation in 2015. Although several trees have succumbed to the blight, the vast majority are still growing vigorously.

## RESEARCH SITE 4: GENETICS STUDIES AT THE YALE PINE AND FIR PLANTATIONS (FRANCOIS MERGEN)

### Summary

These are two old research sites established on opposite sides of the GMF property: a pine tree plantation to the west, and a fir plantation to the east. Both contain wide varieties of native and exotic species, and many hybridized combinations. By studying their relative growth characteristics over time, Francois Mergen hoped to identify species with superior sawfly resistance genes among the pines, and superior timber quality among the firs.

### Access

The Pinetum sits on the east side of Canaan Mountain Rd., at the northern curve where it becomes Wangum Rd. Visitors may park at the GMF West Office and walk up, or park (carefully) on the grassy strip along the road.

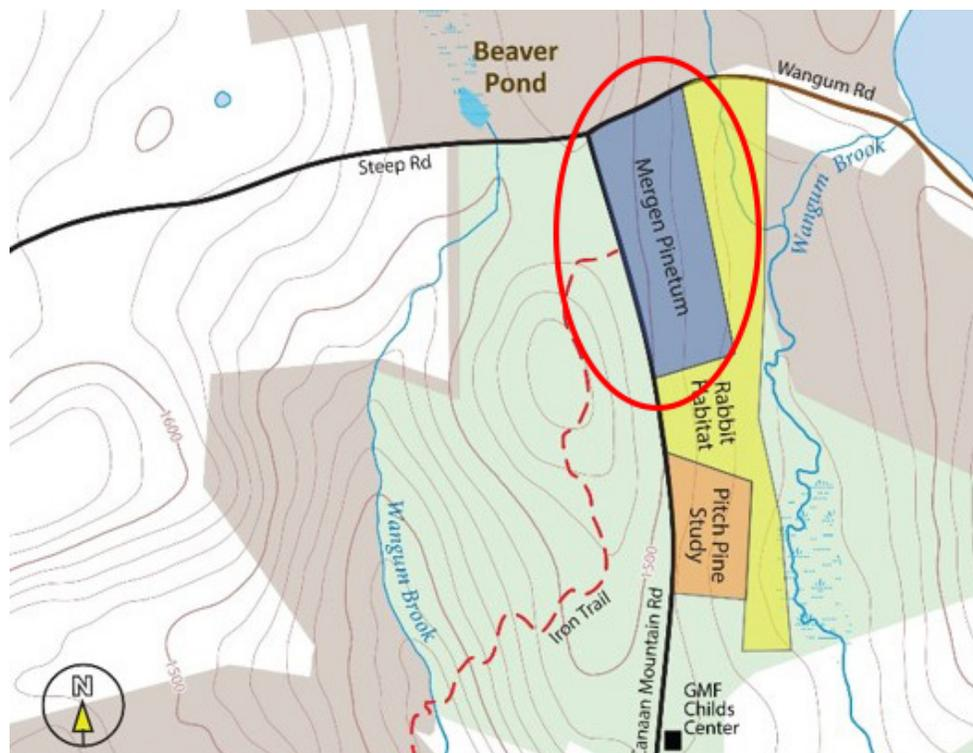

Mergen Pinetum: N 41°58'21.93"; W73°16'19.76"

The Fir Plantation is on the other side of the property, near the corner of Windrow Road and Gamefield Road. Visitors may park in the designated lot by the kiosk near the Forestry office.

### Location

See included maps.

### *Mergen Pinetum*

N 41°58'21.93"

W73°16'19.76"

### Nearby or Comparable Sites

The Pinetum sits directly adjacent to the eastern cottontail rabbit habitat (Forest Management 10), the pitch pine plantation (Research Sites 5), and near the entrance to the Stone Man Trail (Geologic Features 7).

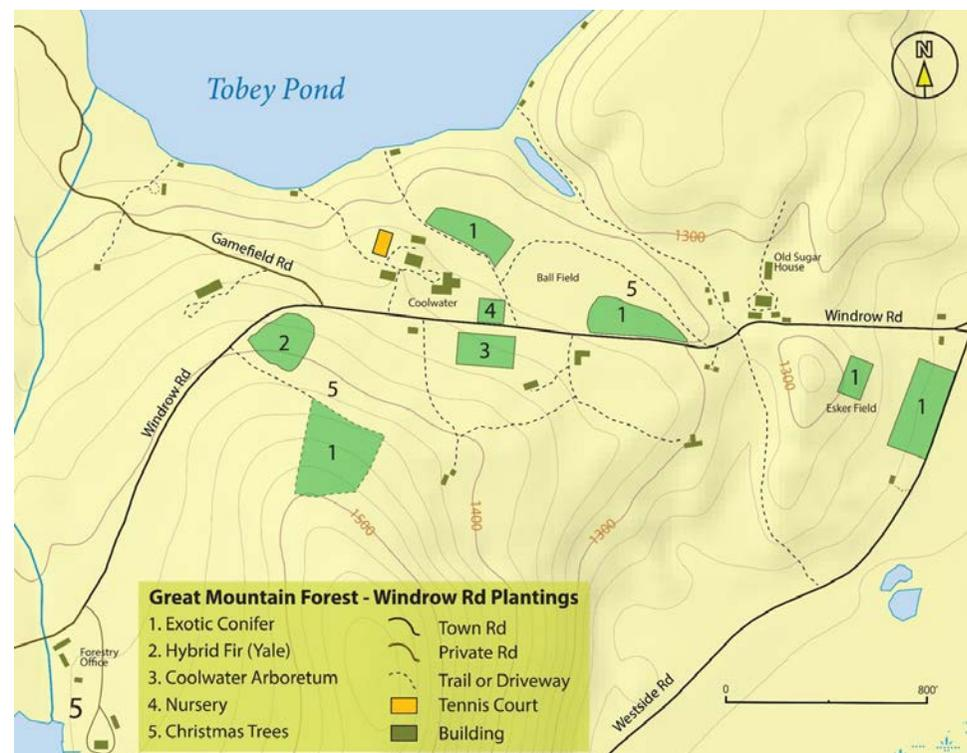

Fir Plantation.

The Fir Plantation is close to the Sugar Sap House (Forest Management 8) and the Red Pine Salvage Site (Forest Management 6) on the eastern side of the property.

### Description

The pine genetics plantation was established in 1958 by Francois Mergen, the former dean and professor of forestry at the (then named) Yale School of Forestry. The goal was to study the relationship between the invasive European pine sawfly (*Neodiprion sertifer*), introduced to North America in 1925, and various species and hybrids of pines in the *sylvestris* sub-genus (the so-called yellow, or hard pines). The larvae of this species of sawfly grow nestled at the base of needle clusters of mature trees, and grow to be adults by eating the fresh leaf shoots each spring. By stocking the plantation with a variety of pine species and hybrids, Mergen hoped to discover the relative resistances of each to the sawfly infestation, with an eye towards breeding more resilient pines for timber production.



The Mergen Pinetum today. Many of the original pine individuals have died away. The others are nearly impossible to identify, as they are a complex series of hybrids arranged randomly in grids.

At the time of this study, large infestations of the European sawfly were ravaging plantations of red pine throughout the Great Mountain Forest. Some of these were adjacent to the genetic study plantings, which ensured there would be a steady source of the insect for the purposes of the long term experiment. Mergen planted a huge variety of pines, both domestic and exotic, including hybrids. Intriguing gems include crosses of the Chinese Yunnan pine (*Pinus yunnanensis*) with the Japanese black pine (*P. thunbergii*), and cultivars of the Mediterranean black pine. Individuals from the same species were often further sourced from various provenances, to see if regional genetic variation might be a factor in the ability of trees to resist the sawfly. For example, Scots pines (*P. sylvestris*) from Scotland, England, Australia, Spain, France, Finland, Sweden, Czechoslovakia, and Turkey are all present in the plantation.

To ensure that all the planted trees started off with the same blank slate of zero sawfly infestation, they were all treated with DDT for the first few years of the study—a compound now known to have extremely harmful environmental effects. Rachel Carson's book "Silent Spring", a book that details the myriad negative impacts of the pesticide (among others) on various spheres of environmental health, was published in 1962, four years after the establishment of the plantation. It is perhaps ironic that DDT would be outlawed in the U.S. in 1972, just two years following the publication of this study. It is a good example of how reading research from the past can provide a window into the world where it was conducted. Chemicals we would not use today were a less questioned presence fifty years ago and more. How will society regard our current day environmental practices fifty years from now?

In 1960 Francois Mergen set up a second genetics plantation, this time of fir tree species on the opposite side of the GMF property. The goal of this genetics study was to see what hybrid crosses, if any, would produce trees with superior growth form characteristics. Like the pine genetics study, these were representative species from all over the world, crossed in novel ways, and planted in huge randomized blocks. As noted in the discussion section, there are no native fir trees in the Great Mountain Forest region. Both of these studies were essentially conducted with the intent of producing vigorous trees for timber production in plantation settings. Again, as with the DDT usage, times have changed. Forestry research and practice today, as a whole, is more focused on maintaining the resilience of entire naturally occurring forest ecosystems rather than creating a few new super-trees for the sawmill.

### Researcher Contact

Dr. Timothy Gregoire, Professor, Yale School of Forestry and Environmental Studies

Timothy.gregoire@yale.edu

### Resources

Henson, W.R., L. C. O'Neil, and F. Mergen. (1970) *Natural variation in susceptibility of Pinus to Neodiprion sawflies as a basis for the development of a breeding scheme for resistant trees. Yale F&ES Bulletin no. 78, Yale University*

Mergen, F. and T. R. Gregoire (1988) *Growth of hybrid fir trees in Connecticut. Silvae Genetica 37: 118-124*

## RESEARCH SITE 5: PITCH PINE PLANTATION STUDY

### Summary

Pitch Pine (*Pinus rigida*) is a tree species mostly known in the fire-prone Pine Barrens ecosystem of southern New Jersey. Though too coarse grained to be a source of quality timber, pitch pine's numerous hard knots produce impressive quantities of resin, for which it was harvested to make tar, pitch, and turpentine to use in the iron working industry. Never an abundant species in Connecticut to begin with, extensive exploitation throughout the 1800s removed it almost completely from the forested landscape. This plantation, established in 1974 to study the heritable characteristics of a dwarf ecotype of the species, is one of the only places where pitch pine can be found in the Great Mountain Forest region today.

### Access

The plantation sits behind a forested buffer on the east side of Canaan Mountain Rd, just north of the GMF administrative headquarters. Visitors may park there, or (carefully) on the grassy strip along the road.

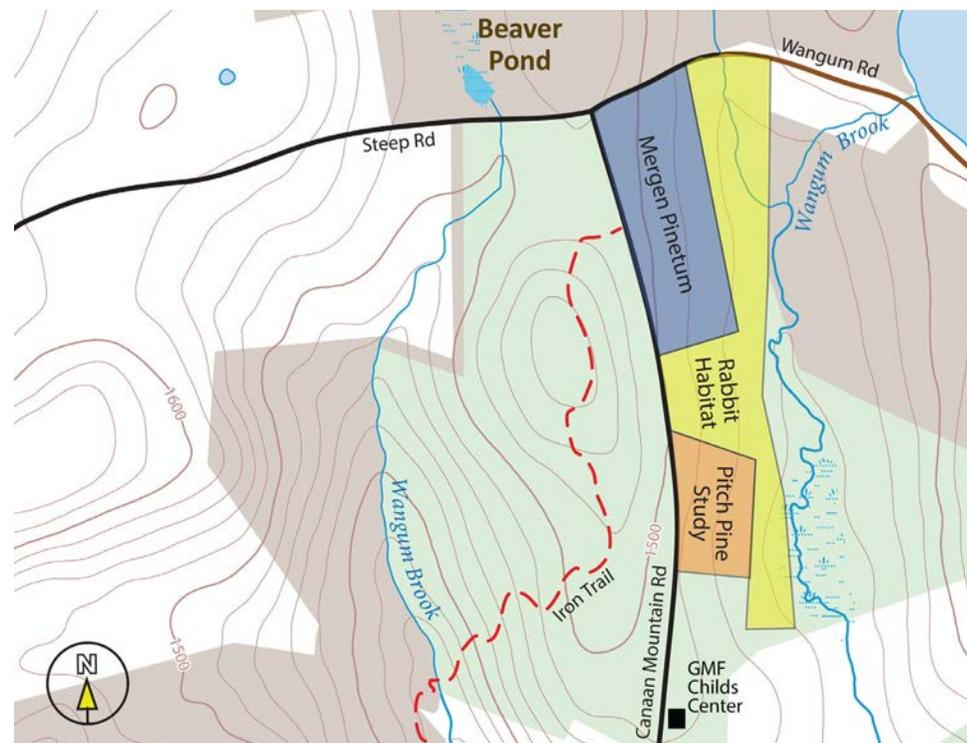

Map of Pitch Pine Plantation: N 41 58'9.18; W 73 16'15.89

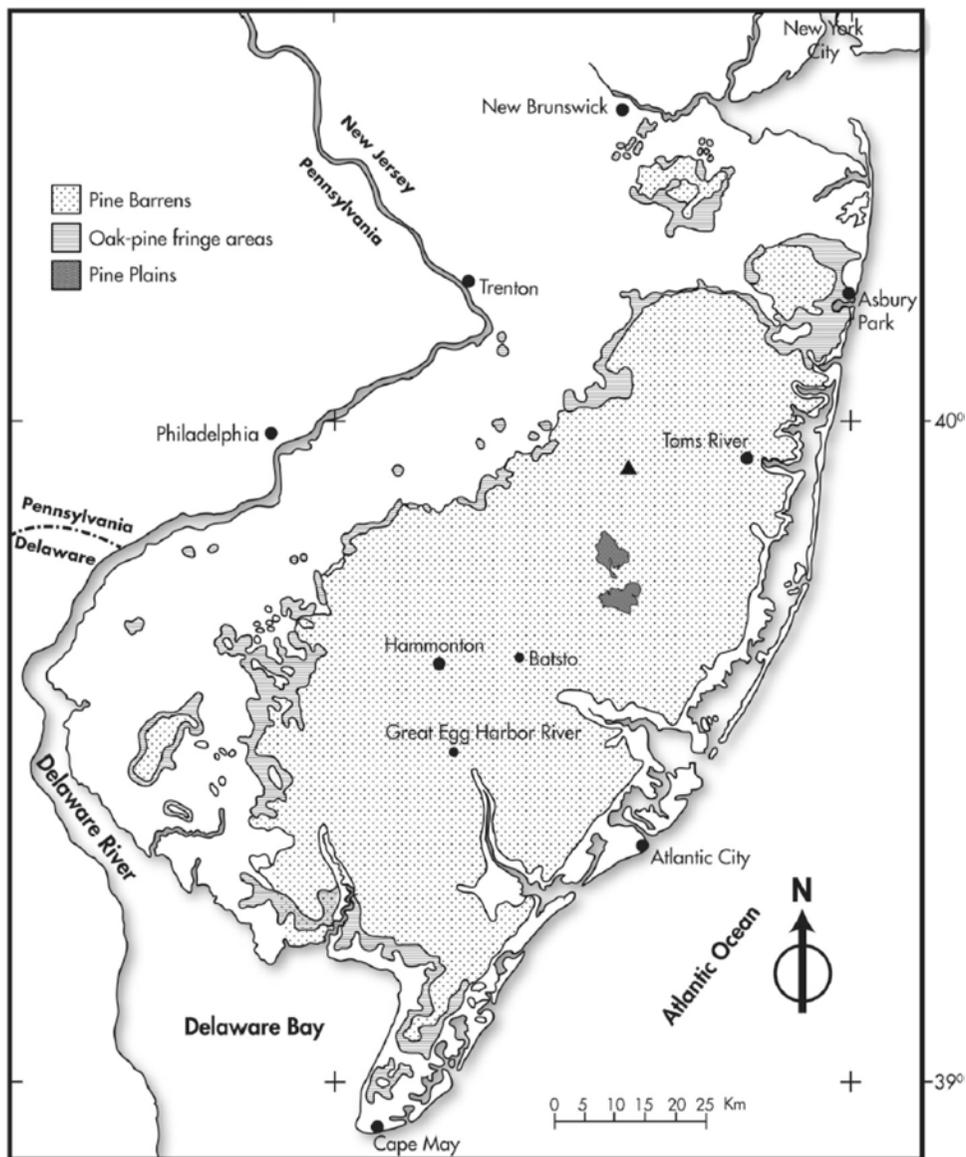

Map of the New Jersey Pine Barrens, where seed for this study was sourced (from Ledig et al. 2013)

#### Location

See included map.

#### *Pitch Pine Plantation*

N 41 58'9.18

W 73 16'15.89

#### Nearby or Comparative Sites

The plantation is adjacent to the eastern cottontail rabbit conservation area (Forest Management 10), Francois Mergen's pinetum (Research Sites 5), and is near the start of the Stone Man Trail (Geologic Sites 8) across the street to the west.

#### Description

The purpose of this study was to investigate possible mechanisms for the difference in tree morphology among pitch pines growing in the New Jersey Pine Barrens proper, and those growing in the slightly elevated Pine Plains embedded within the Barrens region. Due to differences in physiography, the Pine Plains experience more frequent fires than the surrounding Pine Barrens, and it has long been thought that this is why the trees that grow there are distinctively more stunted and crooked. However, it remained unclear whether this modified morphology is actively passed on to progeny, or merely the predictable response of genetically similar pitch pine individuals to habitats with more regular fire disturbance.

To test the heritability of the Pine Plains growth form, Ledig et al. collected pitch pine cones from different provenances of both Pine Barrens and Pine Plains, and planted individuals of both species side by side in controlled garden sites elsewhere. One of these sites is the plantation in the Great Mountain Forest, with others located in Massachusetts, New Jersey, and South Korea. They found that even when grown in identical conditions within each of these sites, the offspring from Pine Plains individuals still varied distinctly from those of the Pine Barrens. They were, on the whole, shorter and more crooked in form, and a much higher proportion of them produced serotinous cones (cones that only open in response to some environmental trigger—fire, in the case of pitch pines). From these results, Ledig et al. conclude that the Pine Plain pitch pines constitute a genetically distinct ecotype of the species, growing in a “pocket of variability” within the greater Pine Barrens ecosystem. They speculate that these so-called dwarf trees may have originated during the last glacial period, when the then frigid New Jersey climate just south of the ice sheet might have selected for a more stunted growth form, like the krumholtz trees that grow along the timber line in boreal Canada and Alaska today.

The methods section describes the untimely demise and abandonment of the plantation sites in Massachusetts and Korea partway through the study, due to high mortality from herbivory, harsh winters, and lack of maintenance. At the GMF plantation, the pitch pine still standing

today are but a fraction of those initially planted—about 20%. The trees from New Jersey provenances are not adapted to survive the much colder winters experienced in New England. This is one reason why the American chestnut plantation at GMF is planted with seed from local sources.

#### Researcher Contact

Tom Ledig, Professor of Plant Sciences, University of California  
tomledig100@gmail.com

#### Resources

Ledig, F. T., J. L. Hom, and P. E. Smouse. 2013. *The evolution of the New Jersey Pine Plains. American Journal of Botany* 100: 778-791



The pitch pine plantations today. Despite high levels of mortality during the early stages of the project, the remaining trees are growing healthily.



Pitch Pine cones, decidedly not serotinous.

## RESEARCH SITE 6: CARBON FLUX TOWER

### Summary

The carbon flux tower was active from 1999-2005, used to study feedback cycles of gases in the atmosphere. Though not currently in use, the tower still stands and can be visited by curious meteorology lovers of all strata.

### Access

Visitors may park in the guest lot near the Forestry Office, then walk a short way west on Camp Road to reach the carbon flux tower.

### Location

*Carbon Flux Tower:* N 41°58'10.78"; W 73°13'50.90"

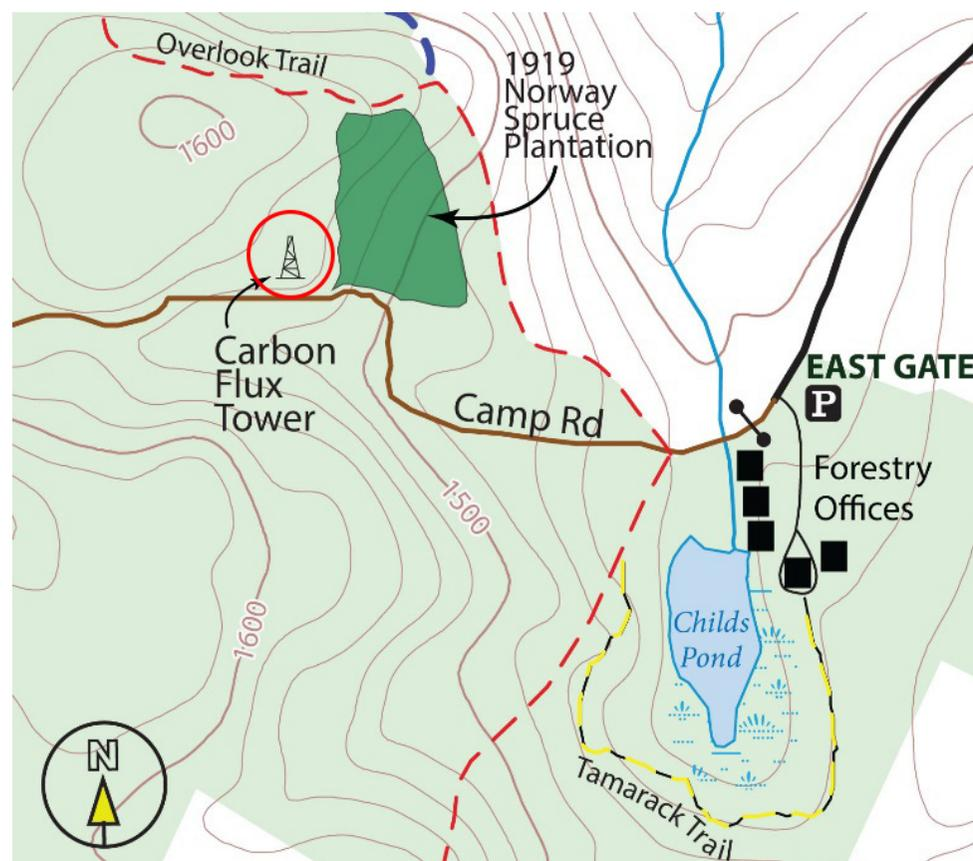

Map of Carbon Flux Tower location: N 41°58'10.78"; W 73°13'50.90"

### Description

The carbon flux tower is a structure used for measuring the exchange cycles of carbon dioxide and water between the earth and the atmosphere. The instruments at the top operate by measuring trace gases in the vertical component of wind flow over time (known as eddy covariance methods). By gathering together data on air speed, humidity, temperature, and gas concentration, researchers can generate detailed information about atmospheric feedbacks related to phenomena like forest fires, soil, plant, and animal respiration, and the burning of fossil fuels.

The tower at GMF was erected by Dr. Xuhui Lee's lab in 1999 as part of FluxNet—a worldwide network of over 683 tower sites with the mission of collecting global data on element fluxes within the atmosphere. To date, data collected from the GMF tower has yielded nine published scientific papers, with studies on soil and forest respiration, ratios of water vapor isotopes, and the prevalence of atmospheric mercury resulting from anthropogenic processes. The most recently published study, which investigates the impact of deforestation on cooling surface feedbacks (Lee et al. 2011), utilized data collected from 33 FluxNet towers, illustrating the potential for meaningful (and powerful) scientific collaboration through the network.

Though only operational through the end of 2005, the carbon flux tower yielded a wealth of impressive data and discoveries through the hard work of Dr. Lee and his colleagues. Pending an application for additional funding, it is hoped that the site will become active once more in the future.

### Researcher Contact

Dr. Xuhui Lee, Yale University School of Forestry and Environmental Studies  
xuhui.lee@yale.edu

### Resources

*The Great Mountain Forest Tower on the Fluxnet Database:* <http://fluxnet.ornl.gov/site/883>

Lee X, ML Goulden, DY Hollinger, A Barr, TA Black, G Bohrer, R Bracho, B Drake, A Goldstein, L Gu, G Katul, T Kolb, B Law, H Margolis, T Meyers, R Monson, W Munger, R Oren, K T Paw U, AD Richardson, HP Schmid, R Staebler, S Wofsy, L Zhao (2011) Observed increase in local cooling effect of deforestation at higher latitudes. *Nature* 479: 384-387.

Wu HJ, X Lee (2011) Short-term effects of rain on soil respiration in two New England forests. *Plant and Soil* 338: 329-342.

Lee X, TJ Griffis, JM Baker, KA Billmark, K Kim, LR Welp (2009) Canopy-scale kinetic fractionation of atmospheric carbon dioxide and water vapor isotopes. *Global Biogeochemical Cycles* 23: GB1002, doi:10.1029/2008GB003331

Lee X, K Kim, R Smith (2007) Temporal variations of the isotopic signal of the whole-canopy transpiration in a temperate forest. *Global Biogeochemical Cycles* 21: GB3013, doi:10.1029/2006GB002871.

Sigler J, X Lee (2006) Recent trends in anthropogenic mercury emission in the northeast United States. *Journal of Geophysical Research – Atmospheres* 111: Art# D14316.

Lee X, R Smith, J Williams (2006) Water vapor  $^{18}\text{O}/^{16}\text{O}$  isotope ratio in surface air in New England, USA. *Tellus B* 58: 293-304.

Lee X, HJ Wu, J Sigler, JC Oishi, T Siccama (2004) Rapid and transient response of soil respiration to rain. *Global Change Biology* 10:1017-1026.

Lee X, X Hu (2002) Forest-air fluxes of carbon and energy over non-flat terrain. *Boundary-Layer Meteorology* 103: 277-301.

Lee X., OR Bullock Jr, RJ Andres (2001) Anthropogenic emission of mercury to the atmosphere in the northeast United States. *Geophysical Research Letters* 28: 1231-1234.



Researcher climbing the tower to adjust equipment. In order to operate properly, all instruments must be positioned well above the surrounding tree canopy line, yet within range of the average wind speed for the area, so as to collect data consistent with other flux towers.



View of the sonic anemometers high above Great Mountain Forest. These devices detect pulses of ultrasonic sound waves as a means of measuring wind velocity. Other essential equipment includes the infrared gas analyzer for measuring the elements or molecules of interest, and a hygrometer for determining the relative humidity of wind samples.



View of the base of the tower, with a deep concrete foundation to keep it in place.





# RESEARCH BIBLIOGRAPHY

## APPENDIX I

### Published Peer-Reviewed Scientific Papers and Graduate Theses Conducted at GMF

- Berthrong, S.T., and A.D. Finzi. (2006). Amino acid cycling in three cold-temperate forests of the northeastern USA. *Soil Biology and Biochemistry* 38: 861-869.
- Bertrand, M. B. and M. L. Wilson. (1996) Microclimate-dependent survival of unfed adult *Ixodes scapularis* (Acari: Ixodidae) in nature: Life cycle and study design implications. *Journal of Medical Entomology* 33: 619-627.
- Bigelow, S. W. and C. D. Canham. (2002). Community organization of tree species along soil gradients in a north-eastern USA forest. *Journal of Ecology* 90: 188-200.
- Bigelow, S. W. and C. D. Canham. (2007). Nutrient limitation of juvenile trees in a northern hardwood forest: Calcium and nitrate are preeminent. *Forest Ecology and Management*, 243:310-319.
- Bigelow, S. W. and C. D. Canham. (2010). Evidence that soil aluminum enforces site fidelity of southern New England forest trees. *Rhodora* 112:1-21.
- Bolker, B. M., S. W. Pacala, F. A. Bazzaz, C. D. Canham, and S. A. Levin. (1995) Species diversity and ecosystem response to carbon dioxide fertilization: conclusions from a temperate forest model. *Global Change Biology* 1:373-381.
- Booth, M.G. (2004) Mycorrhizal networks mediate overstorey-understorey competition in a temperate forest. *Ecology Letters* 7: 538-546
- Booth, M.G. (2005) On the ecology of ectomycorrhizal networks between overstorey trees and seedlings in a New England forest stand. Yale University PhD Dissertation.
- Canham, C.D., A.C. Finzi, S.W. Pacala, and D.H. Burbank (1994) Causes and consequences of resource heterogeneity in forests: interspecific variation in light transmission by canopy trees. *Canadian Journal of Forest Research* 24: 337-349.
- Canham, C.D., R.K. Kobe, E.F. Latty, and R.L. Chazdon (1999) Interspecific and intraspecific variation in tree seedling survival: effects of allocation to roots vs. carbohydrate reserves. *Oecologia*, 121: 1-11 (From TNC)
- Caspersen, J. P., and R. K. Kobe. 2001. Interspecific variation in sapling mortality in relation to growth and soil moisture. *Oikos* 92:160-168.
- Childs, Edward C. (1932) The genus *Tsuga*: with special attention to the silvical characteristics and their relation to the economic position of the eastern hemlock among the timber trees of New England. Yale University PhD Thesis.
- Damman, A.W.H., and B. Kershner (1977) Floristic composition and topographical distribution of the forest communities of the gneiss areas of western Connecticut. *Le Naturaliste Canadien* 104: 23-45
- Deutschman, D., S.A. Levin, and S.W. Pacala (1999) Error propagation in forest succession models: The role of fine-scale heterogeneity in light. *Ecology* 80: 1927-1943.
- Dijkstra, F. A., C. Geibe, S. Holmstrom, U. S. Lundstrom, and N. van Breemen. (2001). The effect of organic acids on base cation leaching from the forest floor under six North American tree species. *European Journal of Soil Science* 52:205-214.
- Dijkstra, F. A., and M. M. Smits. (2002). Tree species effects on calcium cycling: The role of calcium uptake in deep soils. *Ecosystems* 5:385-398.
- Dijkstra, F. A. (2003). Calcium mineralization in the forest floor and surface soil beneath different tree species in the northeastern US. *Forest Ecology and Management* 175:185-194.

- Dijkstra, F. A., and R. D. Fitzhugh. (2003). Aluminum solubility and mobility in relation to organic carbon in surface soils affected by six tree species of the northeastern United States. *Geoderma* 114:33-47.
- Dijkstra, F. A., N. Van Breemen, A. G. Jongmans, G. R. Davies, and G. E. Likens. (2003). Calcium weathering in forested soils and the effect of different tree species. *Biogeochemistry* 62:253-275.
- Finzi, A.C., and C.D. Canham. (1998) Non-additive effects of litter mixtures on net N mineralization in a southern New England Forest. *Forest Ecology and Management* 105: 129-136.
- Finzi, A.C., C.D. Canham, and N. van Breemen (1998) Canopy tree-soil interactions within temperate forests: species effects on pH and cations. *Ecological Applications* 8: 447-454 site east of Wampee pond.
- Finzi, A.C., N. van Breeman, and C.D. Canham (1998) Canopy tree-soil interactions within temperate forests: species effects on carbon and nitrogen. *Ecological Applications* 8: 440-446
- Finzi, A.C. and C.D. Canham (2000) Sapling growth in response to light and nitrogen availability in a southern New England forest. *Forest Ecology and Management* 131: 153-165
- Finzi, A.C. and S.T. Berthrong. (2005). The uptake of amino acids by microbes and trees in three cold-temperate forests. *Ecology* 86: 3345-3353.
- Finzi, A.C. (2009) Decades of atmospheric deposition have not resulted in widespread phosphorus limitation or saturation of tree demand for nitrogen in southern New England. *Biogeochemistry* 92: 217-229.
- Finzi, A.C., and V.L. Rodgers. (2009). Bottom-up rather than top-down processes regulate the abundance and activity of nitrogen fixing plants in two Connecticut old-field ecosystems. *Biogeochemistry* 95: 309-321.
- Gallet-Budynek, A., E. Brzostek, V.L. Rodgers, J.M. Talbot, S. Hyzy, and A.C. Finzi. (2009). Instant amino acid uptake by northern hardwood and conifer trees. *Oecologia* 160: 129-138.
- Gibbs, J.P. (1998) Genetic structure of redback salamander *Plethodon cinereus* populations in continuous and fragmented forests. *Biological Conservation* 86: 77-81
- Gómez-Aparicio, L. and C. D. Canham. 2008. Neighborhood models of the effects of invasive tree species on ecosystem processes. *Ecological Monographs* 78:69-86.
- Gómez-Aparicio, L. and C. D. Canham. 2008. A neighborhood analysis of the allelopathic effects of the invasive tree *Ailanthus altissima* in temperate forests. *Journal of Ecology* 96:447-458.
- Gómez-Aparicio, L., C. D. Canham, and P. H. Martin. 2008. Neighborhood models of the effects of the invasive *Acer platanoides* on tree seedling dynamics: linking impacts on communities and ecosystems. *Journal of Ecology* 96:78-90.
- Graves, A.H. (1950). Relative blight resistance in species and hybrids of *Castanea*. *Phytopathology* 40: 1125-1131.
- Hamlin, E. (1991). *Bog Essays*. Wesleyan University Master's Thesis (Liberal Studies).
- Henson, W.R., L. C. O'Neil, and F. Mergen. (1970) Natural variation in susceptibility of *Pinus* to *Neodiprion* sawflies as a basis for the development of a breeding scheme for resistant trees. *Yale F&ES Bulletin* no. 78, Yale University
- Hill, James D., and J.A. Silander Jr. (2001). Distribution and dynamics of two ferns: *Dennstedtia punctilobula* (Dennstaedtiaceae) and *Thelypteris noveboracensis* (Thelypteridaceae) in a northern mixed hardwoods-hemlock forest. *American Journal of Botany* 88: 894-902.
- Hussein, A. (1979). The reestablishment of the eastern wild turkey in Connecticut. Department of Environmental Protection Research Report, State of Connecticut. 48 pp.
- Jenkins, J. C., C. D. Canham, and P. K. Barton. 2000. Predicting long-term forest development following hemlock mortality. pp. 62-75 in K. A. McManus, K. S. Shields, and D. R. Souto, eds., *Proceedings: Symposium on Sustainable Management of Hemlock Ecosystems in Eastern North America*. USDA Forest Service General Technical Report NE-267.
- Karwan, D.L., and J.E. Saiers (2009). Influences of seasonal flow regime on the fate and transport of fine particles and a dissolved solute in a New England stream. *Water Resources Research* 45: W11423.

- Karwan, D.L., and J.E. Saiers (2012). Hyporheic exchange and streambed filtration of suspended particles. *Water Resources Research* 48: W01519.
- Kelty, M.J. (1984) The Development and Productivity of Hemlock-Hardwood forests in Southern New England. Yale University PhD Thesis.
- Kelty, M.J. (1986) Development patterns in two hemlock-hardwood stands in southern New England. *Canadian Journal of Forest Research* 16: 885-891
- Kelty, M.J. (1989) Productivity of New England hemlock/hardwood stands as affected by species composition and canopy structure. *Forest Ecology and Management* 28: 237-257.
- Kimmins, J.P. (1970). Cyclic fluctuations in herbivore populations in northern ecosystems. A general hypothesis. Yale University PhD Thesis.
- Kimmins, J.P. (1972). Relative contributions of leaching, litter-fall, and defoliation by *Neodiprion sertifer* (Hymenoptera) to the removal of Cesium-134 from red pine. *Oikos* 23: 226-234.
- Kobe, R.K., S.W. Pacala, J.A. Silander, Jr., and C.D. Canham. (1995) Juvenile tree survivorship as a component of shade tolerance. *Ecological Applications* 5:517-532.
- Kobe, R. K. (1996). Intraspecific variation in sapling mortality and growth predicts geographic variation in forest composition. *Ecological Monographs* 66:181-201.
- Kobe, R.K. (1997). Carbohydrate allocation to storage as a basis of interspecific variation in sapling survivorship and growth. *Oikos* 80: 226-233.
- Ledig, F. T., J. L. Hom, and P. E. Smouse. 2013. The evolution of the New Jersey Pine Plains. *American Journal of Botany* 100: 778-791
- Lee X., OR Bullock Jr, RJ Andres (2001) Anthropogenic emission of mercury to the atmosphere in the northeast United States. *Geophysical Research Letters* 28: 1231-1234.
- Estimation of Hg emissions on a local scale, using data collected at the meteorological tower site at GMF.
- Lee X, X Hu (2002) Forest-air fluxes of carbon and energy over non-flat terrain. *Boundary-Layer Meteorology* 103: 277-301.
- Lee X, HJ Wu, J Sigler, JC Oishi, T Siccama (2004) Rapid and transient response of soil respiration to rain. *Global Change Biology* 10:1017-1026.
- Study of the pulses of soil respiration rates in response to rain events. Data is collected from soil pits dug near the meteorological tower site at GMF
- Lee X, R Smith, J Williams (2006) Water vapor  $^{18}\text{O}/^{16}\text{O}$  isotope ratio in surface air in New England, USA. *Tellus B* 58: 293-304.
- Investigation of patterns of the water/vapor mixing rates of different isotopes, from Rainwater collected at GMF and in New Haven. Conducted at the meteorological tower site at GMF.
- Lee X, K Kim, R Smith (2007) Temporal variations of the isotopic signal of the whole-canopy transpiration in a temperate forest. *Global Biogeochemical Cycles* 21: GB3013, doi:10.1029/2006GB002871.
- Study of evapotranspiration flux of different isotopes of water vapor over the course of a growing season. Conducted at the meteorological tower site at GMF
- Lee X, TJ Griffis, JM Baker, KA Billmark, K Kim, LR Welp (2009) Canopy-scale kinetic fractionation of atmospheric carbon dioxide and water vapor isotopes. *Global Biogeochemical Cycles* 23: GB1002, doi:10.1029/2008GB003331
- Investigation of the impact of landscape roughness on the fractionation of  $\text{CO}_2$  and  $\text{H}_2\text{O}$  isotopes. Conducted at the meteorological tower site at GMF.
- Lee X, ML Goulden, DY Hollinger, A Barr, TA Black, G Bohrer, R Bracho, B Drake, A Goldstein, L Gu, G Katul, T Kolb, B Law, H Margolis, T Meyers, R Monson, W Munger, R Oren, K T Paw U, AD Richardson, HP Schmid, R Staebler, S Wofsy, L Zhao (2011) Observed increase in local cooling effect of deforestation at higher latitudes. *Nature* 479: 384-387.
- Study on the potential for deforested areas in low to mid latitudes to create a cooling effect from albedo effect. Conducted at the meteorological tower site at GMF.
- Liptzin, D., and P.M.S. Ashton (1999) Early-successional dynamics of single-aged mixed hardwood stands in a southern New England forest, USA. *Forest Ecology and Management* 116: 141-150.
- Lutz, H.J. and H.H. Chapman (1944) Injuries to young tree trunks from antler rubbing by deer. *Journal of Wildlife Management* 8: 80-81

- Maier, C.T. (2005) First North American records of *Batrachedra pinicolella* (Lepidoptera: Batrachedridae), a Palearctic needleminer of spruces. *Canadian Entomology* 137: 188-191.
- Martin, P. H., C. D. Canham, and P. L. Marks. (2009). Why forests appear resistant to exotic plant invasions: intentional introductions, stand dynamics, and the role of shade tolerance. *Frontiers in Ecology and the Environment* 7:142-149.
- Martin, P. H. and C. D. Canham. (2010). Dispersal and recruitment limitation in native versus exotic tree species: life-history strategies and Janzen-Connell effects. *Oikos* 119:807-824.
- Martin, P. H., C. D. Canham, and R. K. Kobe. (2010). Divergence from the growth-survival trade-off and extreme high growth rates drive patterns of exotic tree invasions in closed-canopy forests. *Journal of Ecology* 98:778-789.
- Maynard, A. (1989) Interaction of aluminum with forest soils and vegetation implications for acid deposition. Yale University PhD thesis.
- Mergen, F. and T. R. Gregoire (1988) Growth of hybrid fir trees in Connecticut. *Silvae Genetica* 37: 118-124
- Mickelson, J.G. Jr. (1997) Delineating landscape scale vegetation patterns for northwest Connecticut using multi-seasonal satellite imagery and GPS referenced field data. University of Connecticut Master's Thesis.
- Mickelson, J.G. Jr., D.L. Civko, and J.A. Silander Jr. (1998) Delineating forest canopy species in the northeastern United States using multi-temporal TM imagery. *Photogrammetric Engineering & Remote Sensing* 64: 891-904.
- Pacala, S.W., C.D. Canham, and J.A. Silander, Jr. (1993) Forest models defined by field measurements: I. The design of a northeastern forest simulator. *Canadian Journal of Forest Research* 23: 1980-1988
- Unveiling of the new SORTIE model of forest structure and dynamics, calibrated using dominant tree species data from GMF. Includes submodels for growth, recruitment, mortality, and resources.
- Pacala, S.W., C.D. Canham, J.A. Silander, Jr., and R.K. Kobe. (1994) Sapling growth as a function of resources in a north temperate forest. *Canadian Journal of Forest Research* 24: 2172-2183.
- Pacala, S.W., C.D. Canham, J.A. Silander, Jr., and R.K. Kobe. (1996) Forest models defined by field measurements: II. Estimation, error, analysis, and dynamics. *Ecological Monographs* 66: 1-43.
- Papaik, M.J., and C. D. Canham. 2006. Multi-model analysis of tree competition along environmental gradients in southern New England forests. *Ecological Applications* 16:1880-1892.
- Pontius, J., R. Hallett, and M. Martin. (2002). Examining the role of foliar chemistry in hemlock woolly adelgid infestation and hemlock decline. In *Proceedings: Symposium on the Hemlock Woolly Adelgid in the Eastern United States*, East Brunswick, N.J., 5-7 February 2002. Edited by B. Onken, R. Reardon, J. Lashomb. N.J. Ag. Exp. Sta., Rutgers University, East Brunswick, N.J. pp. 86-99
- Ribbens, E., S.W. Pacala, and J.A. Silander, JR. (1996) Seedling recruitment in forests - calibrating models to predict patterns of tree seedling dispersion. *Ecology* 75: 1794-1806
- Rodgers, V.L. (1999). Impacts of *Alliaria petiolata* (garlic mustard) invasion on plant diversity and soil nutrient cycling in northern hardwood-conifer forests. Boston University PhD dissertation.
- Rodgers, V.L., B. E. Wolfe, L. K. Werden, and A. D. Finzi (2008). The invasive species *Alliaria petiolata* (garlic mustard) increases soil nutrient availability in northern hardwood-conifer forests. *Oecologia* 157: 459-471.
- Rodgers, V.L., K.A. Stinson, and A.C. Finzi. (2008). Ready or not, garlic mustard is moving in: *Alliaria petiolata* as a member of eastern North American forests. *Bioscience* 58: 426-436.
- Schnurr, J.L. (2000). The relationships among habitat distribution, small mammal activity patterns, seed survival, and seedling recruitment in temperate deciduous forests. Idaho State University PhD Thesis.
- Schnurr, J.L., C.D. Canham, and R.S. Ostfeld (1998) Escape from seed predation in temperate forests: the effects of interspecific variation in seed production. *Ecological Society of America*, 83rd Annual Meeting, abstracts. 117 p.
- Schnurr, J.L., R.S. Ostfeld, and C.D. Canham. (2002). Direct and indirect effects of masting on rodent populations and tree seed survival. *Oikos* 96: 402-410.

- Schnurr, J.L., C.D. Canham, R.S. Ostfield, and R.S. Inouye. (2004). Neighborhood analyses of small-mammal dynamics: impacts on seed predation and seedling establishment. *Ecology* 85: 741-755.
- Shaw, S.B. and S.J. Riha (2011). Assessing temperature-based PET equations under a changing climate in temperate, deciduous forests. *Hydrological Processes* 25: 1466-1478.
- Sigler J, X Lee (2006) Recent trends in anthropogenic mercury emission in the northeast United States. *Journal of Geophysical Research – Atmospheres* 111: Art# D14316.
- Smith, D.M., and P.M.S. Ashton (1993). Early dominance of pioneer hardwood after clearcutting and removal of advanced regeneration. *Northern Journal of Applied Forestry* 10: 14-19
- Stephens, G.R. (1971) The relation of insect defoliation to mortality in Connecticut Forests. Connecticut Agricultural Experiment Station, New Haven. Bulletin 723. 16 pp.
- Stephens, G.R. and D.E. Hill (1973) Drainage, drought, defoliation, and death in unmanaged woodlands of Connecticut. Connecticut Agricultural Experiment Station, New Haven. Bulletin 718. 50 pp.
- Talbot, J.M. and A.C. Finzi. (2008). Differential effects of sugar maple, red oak, and hemlock tannins on carbon and nitrogen cycling in temperate forest soils. *Oecologia* 155: 583-592.
- Tripler, C.E., and C.D. Canham (1998) Neighborhood effects of canopy tree species on sapling nitrogen contents: implications for foraging patterns by white-tailed deer. Ecological Society of America, 83rd Annual Meeting, abstracts.
- Tripler, C.E., C.D. Canham, R.S. Inouye, and J.L. Schnurr (2002) Soil nitrogen availability, plant luxury consumption, and herbivory by white-tailed deer. *Oecologia* 133: 517-524
- Tripler, C.E., C.D. Canham, R.S. Inouye, and J.L. Schnurr (2005) Competitive hierarchies of temperate tree species: interactions between resource availability and white-tailed deer. *Ecoscience* 12: 494-505
- Van Breeman, N., A.F. Finzi, and C.D. Canham (1997) Canopy tree-soil interactions within temperate forests: Effects of fine-scale variation in soil texture and elemental composition on species distributions. *Canadian Journal of Forest Research* 27: 1110-1116 (from TNC)
- Van Breemen, N., and A. C. Finzi. (1998). Plant-soil interactions: ecological aspects and evolutionary implications. *Biogeochemistry* 42:1-19
- Ward, Jeff. (1992) Resistance of western hemlock (*Tsuga heterophylla* Sargentii) provenances to hemlock wooly adelgid in Connecticut. Connecticut Agricultural Experiment Station, forest pathology project report.
- Ward, Jeff. (2005). Stand dynamics in Connecticut Forests: the new series plots (1959-2000). Connecticut Agricultural Experiment Station, New Haven. Bulletin 995. 36 pp.
- Winslow, R.C. (1975) Successional trends on the Great Mountain Forest, Litchfield County, Connecticut. University of Hartford, Master's thesis, dept. of Biology.
- Winer, H.I. (1955) History of Great Mountain Forest, Litchfield County, Connecticut. Yale University PhD dissertation.
- Wolfe, B.E., V.L. Rodgers, K.A. Stinson, and A. Pringle. (2008). The invasive plant *Alliaria petiolata* (garlic mustard) inhibits ectomycorrhizal fungi in its introduced range. *Journal of Ecology* 96: 777-783.
- Wu HJ, X Lee (2011) Short-term effects of rain on soil respiration in two New England forests. *Plant and Soil* 338: 329-342.
- Zaccherio, M.T., and A.C. Finzi. (2007). Atmospheric deposition may affect northern hardwood forest composition by altering soil nutrient supply. *Ecological Applications* 17: 1929-1941.

## Selected Book Chapters and Magazine/Newspaper Articles Concerning GMF

- Bennett, Dean B. (1995) chapter “Old Forests of the Green-Woods, Connecticut”, in *The Forgotten Nature of New England*. Down East Books, Camden.
- Canham, C.D. and S.W. Pacala (1995) “Linking Tree Population Dynamics and Forest Ecosystem Processes” pp 84-93 in *Linking Species and Ecosystems*. C.G. Jones and J.H. Lawton, ed. Chapman and Hall, New York.
- Carlson, Hans (2015). *A walk up Stoneman: Merging Ecology and history*. Norfolk Now, 7/1  
Available online:  
<http://www.nornow.org/2015/07/01/its-only-natural-a-walk-up-stoneman/>
- Caspersen, J.P., J.A. Silander Jr., C.D. Canham, and S.W. Pacala. (1999) Modeling the competitive dynamics and distribution of tree species along moisture gradients. pp. 14-41 In David Mladenoff and William Baker, eds. *Spatial Modeling of Forest Landscape Change*. Cambridge University Press.
- Childs, Edward C. (1977) “Enjoy your woodlot” in *The Environment and the Home Gardener* (magazine) vol. 33, issue 1 (spring): 41-43.
- Gavitt, Bud (1985) Connecticut farm makes quality syrup (newspaper article) *New England Farmer*, October 1985 pg. B1-B3
- Gural, Natasha (1995) Curling and maple syrup go hand in hand in Norfolk. (newspaper article) *The Register Citizen*, Torrington. 3/19/1995, pg. A1-A4.
- Haskell, Anne (1977) Nine biology students study pristine forest (newspaper article) *The Canaan Journal*, Lakeville 7/19/1973 pg. A1-B1.
- Haskell, Anne (1977) Wildlife species returning to area (newspaper article) *The Register*, Litchfield 7/22/1977
- Haskell, William (1994) Research the focus of Great Mountain (newspaper article) *The Register Citizen*, Torrington 11/10/1994 pg. A1-A7
- Kiefer, G.C., and D.R. Russ (1952) Pulpwood thinning in Norway Spruce (magazine article) *Connecticut Woodlands*, May 1952, 17:26-27.
- (magazine article). *Logging Management* 12/1979.
- Myers, S.L. (1991) Wild turkeys roar back from extinction (newspaper article) *The New York Times* 11/24/1991. Available online: <<http://www.nytimes.com/1991/11/24/weekinreview/ideas-trends-wild-turkeys-roar-back-from-near-extinction.html>>
- Stutz, B. (1993) Stands of time: panoramic views of the last preserves of uncut woodlands on the East Coast (magazine article) *Audubon* 95 (1): 62-78 Feb/Mar 1993.
- Sullivan, P.L. (2014) Trek reminds teens of historic roots (newspaper article). *The Lakeville Journal*, July 3rd, pg. A8.
- Sullivan, P.L. (2015) It’s turning out to be an excellent year for maple syrup (newspaper article) *The Lakeville Journal*, April 9th, pg. A9.
- Sullivan, P.L. (2015). GMF outing: all that was missing was Huck Finn (newspaper article). *The Lakeville Journal*, July 30th, pg. A9.
- Wegner, Robert (1987) White scars of the deer forest (book chapter) in *Deer & Deer Hunting: the Serious Hunter’s Guide*. Stackpole Books, Harrisburg, pp.124-126
- Wood, Wiley. “Connecticut Biologists Create Habitat for the Endangered New England Cottontail.” *Norfolk Now*. 02 June 2013. Web. 21 Aug. 2015. <http://www.nornow.org/2013/06/02/its-only-natural/>.
- Wood, Wiley. “Landowners Make Clear-Cuts To Benefit Rare Cottontail Rabbit.” *Norfolk Now*. 27 Feb. 2015. Web. 21 Aug. 2015. <http://www.nornow.org/2015/02/27/landowners-make-clear-cuts-benefit-rare-cottontail-rabbit/>.
- Mason, Duane (1979) New England forest experimenting with Japanese trees

## Unpublished and Internal GMF Documents of Interest

- Bronson, J. E. (1996). Great Mountain Forest - 1996 Annual Foresters Report (series). GMF.
- Bronson, J. E., and R. M. Russ. (2010). Great Mountain Forest: Forest Stewardship Plan. GMF Corp.
- Childs, Edward C. (1964) Trees and shrubs of the Great Mountain Forest area, Norfolk, CT.- Angiosperms. GMF species list
- Childs, Edward C. (1967) A comparison of 25 years of growth on the Great Mountain Forest, Norfolk, CT. Internal forest growth analysis report.
- Heth, Scott L. Fortin, and J. Markow (1999) Monitoring avian productivity and survivorship (MAPS) station on Canaan Mountain/Great Mountain Forest. Sharon Audubon Center 1998 project report.
- Kiefer, G. C. (1950). Foresters Monthly Report- September 1950. GMF annual forest workings.
- Mickelson, John. (1999). Great Mountain Forest (GMF) conservation evaluation: identifying stewardship and conservation opportunities. Phase I Project Report. Nature Conservancy—CTFO. 64 pp.
- Russ, D. (1967) Trees and shrubs of the Great Mountain Forest- gymnospermae. GMF species list.
- Svantyr, Mark S. (2003-2004) Butterflies of the Great Mountain Forest survey
- Tsao, Kimberly (2008) GMF mammal trapping summary, and associated insect parasites. Yale School of Public Health, Division of Epidemiology of Microbial Diseases.

# COMPLETE SPECIES LIST

## APPENDIX II

### List of Vascular Plant Species Observed at Great Mountain Forest

SPECIES NAME <sup>1</sup>	COMMON NAME <sup>2</sup>
<i>Acer pensylvanicum</i>	Striped maple
<i>Acer rubrum</i>	Red maple
<i>Acer saccharum</i>	Sugar maple
<i>Acer spicatum</i>	Mountain maple
<i>Actaea pachypoda</i>	White baneberry
<i>Actaea rubra</i>	Red baneberry
<i>Adiantum pedatum</i>	Maidenhair fern
<i>Adlumia fungosa</i>	Climbing fumitory
<i>Ageratina altissima</i>	White snakeroot
<i>Agrimonia ?gryposepala</i>	Common agrimony
<i>Agrostis perennans</i>	Hairgrass
<i>Alliaria petiolata</i> *	Garlic mustard
<i>Allium tricoccum</i>	Wild leek
<i>Alnus incana ssp. rugosa</i>	Alder
<i>Ambrosia artemisiifolia</i>	Common ragweed
<i>Amelanchier laevis</i>	Smooth shadbush
<i>Amelanchier species</i>	Serviceberries
<i>Amphicarpaea bracteata</i>	American hog-peanut
<i>Anaphalis margaritacea</i>	Pearly everlasting
<i>Andromeda glaucophylla</i>	Bog rosemary
<i>Anemone americana</i>	Round-lobed hepatica
<i>Anemone quinquefolia</i>	Wood anemone

<i>Anemone virginiana</i>	Canada anemone
<i>Angelica ?atropurpurea</i>	Purplestem angelica
<i>Antennaria ?neglecta</i>	Pussy's-toes
<i>Antennaria plantaginifolia</i>	Pussytoes
<i>Anthoxanthum odoratum</i> *	Sweet vernal grass
<i>Apocynum ?cannabinum</i>	Dogbane
<i>Aquilegia canadensis</i>	Wild columbine
<i>Aralia hispida</i>	Bristly sasparilla
<i>Aralia nudicaulis</i>	Wild sarsaparilla
<i>Aralia racemosa</i>	American spikenard
<i>Arctium minus</i> *	Lesser burdock
<i>Arisaema triphyllum</i>	Jack-in-the-pulpit
<i>Aronia species</i>	Chokeberries
<i>Arrhenatherum elatius</i> *	False oat-grass
<i>Artemisia vulgaris</i> *	Mugwort
<i>Asarum canadense</i>	Wild ginger
<i>Asclepias incarnata</i>	Swamp milkweed
<i>Asclepias syriaca</i>	Common milkweed
<i>Asplenium platyneuron</i>	Ebony spleenwort
<i>Asplenium trichomanes</i>	Maidenhair spleenwort
<i>Athyrium filix-femina</i>	Lady fern
<i>Barbarea vulgaris</i> *	Winter-cress
<i>Berberis thunbergii</i> *	Barberry
<i>Betula alleghaniensis</i>	Yellow birch
<i>Betula lenta</i>	Black birch
<i>Betula papyrifera</i>	Paper birch
<i>Betula populifolia</i>	Gray birch
<i>Bidens species</i>	Beggar-ticks
<i>Boechera laevigata</i>	Smooth rockcress
<i>Boehmeria cylindrica</i>	False-nettle
<i>Botrychium virginianum</i>	Rattlesnake fern
<i>Brachyelytrum erectum</i>	Bearded shorthusk
<i>Bromus inermis</i> *	Smooth brome
<i>Bromus pubescens</i>	Hairy woodland brome
<i>Calamagrostis canadensis</i>	Bluejoint
<i>Calamagrostis stricta ssp. inexpansa</i>	Northern reedgrass
<i>Calla palustris</i>	Calla lily
<i>Caltha palustris</i>	Marsh marigold
<i>Campanula aparinoides</i>	Marsh bellflower

<i>Cardamine concatenata</i>	Cutleaf toothwort
<i>Cardamine diphylla</i>	Broadleaf toothwort
<i>Carex albicans</i> var. <i>albicans</i>	White-tinge sedge
<i>Carex albursina</i>	White bear sedge
<i>Carex amphibola</i>	Eastern narrow-leaved sedge
<i>Carex appalachica</i>	Appalachian sedge
<i>Carex arctata</i>	Drooping woodland sedge
<i>Carex argyrantha</i>	Hay sedge
<i>Carex aurea</i>	Golden sedge
<i>Carex blanda</i>	Common woodland sedge
<i>Carex bromoides</i>	Brome-like sedge
<i>Carex brunnescens</i>	Brownish sedge
<i>Carex canescens</i>	Silvery sedge
<i>Carex cephalophora</i>	Capitate sedge
<i>Carex communis</i>	Fibrous-rooted sedge
<i>Carex comosa</i>	Longhair sedge
<i>Carex crinita</i>	Fringed sedge
<i>Carex cristatella</i>	Crested sedge
<i>Carex debilis</i>	White-edge sedge
<i>Carex deweyana</i>	Dewey sedge
<i>Carex digitalis</i>	Slender woodland sedge
<i>Carex flava</i>	Yellow sedge
<i>Carex folliculata</i>	Northern long sedge
<i>Carex gracillima</i>	Graceful sedge
<i>Carex gracillescens</i>	Slender loose-flowered sedge
<i>Carex granularis</i>	Meadow sedge
<i>Carex hirtifolia</i>	Hairy sedge
<i>Carex hystericina</i>	Porcupine sedge
<i>Carex interior</i>	Inland sedge
<i>Carex intumescens</i>	Greater bladder sedge
<i>Carex lacustris</i>	Lake sedge
<i>Carex laevivaginata</i>	Smooth-sheathed sedge
<i>Carex lasiocarpa</i>	Woolly-fruited sedge
<i>Carex laxiflora</i>	Broad loose-flowered sedge
<i>Carex leptalea</i>	Bristly-stalked sedge
<i>Carex leptoneuria</i>	Nerveless woodland sedge
<i>Carex lupulina</i>	Hop sedge
<i>Carex lurida</i>	Shallow sedge
<i>Carex muricata</i>	Rough sedge

<i>Carex normalis</i>	Greater straw sedge
<i>Carex ?ormostachya</i>	Necklace spike sedge
<i>Carex pedunculata</i>	Long-stalked sedge
<i>Carex pennsylvanica</i>	Pennsylvania sedge
<i>Carex platyphylla</i>	Broadleaf sedge
<i>Carex prasina</i>	Drooping sedge
<i>Carex rosea</i>	Rosy sedge
<i>Carex retroflexa</i>	Reflexed sedge
<i>Carex scabrata</i>	Eastern rough sedge
<i>Carex scoparia</i>	Pointed broom sedge
<i>Carex sparganioides</i>	Bur-reed sedge
<i>Carex sprengeii</i>	Sprengel's sedge
<i>Carex stipata</i>	Awlfruit sedge
<i>Carex stricta</i>	Upright sedge
<i>Carex swanii</i>	Swan's sedge
<i>Carex tetanica</i>	Rigid sedge
<i>Carex trisperma</i>	Three-seeded sedge
<i>Carex virescens</i>	Ribbed sedge
<i>Carex viridula</i>	Little green sedge
<i>Carex vulpinoidea</i>	Fox sedge
<i>Carpinus caroliniana</i>	Hornbeam
<i>Carya cordiformis</i>	Bitternut hickory
<i>Carya glabra</i>	Pignut hickory
<i>Carya ?ovalis</i>	Sweet pignut hickory
<i>Carya ovata</i>	Shagbark hickory
<i>Castanea dentata</i>	American Chestnut
<i>Ceanothus americanus</i>	New Jersey tea
<i>Celastrus orbiculatus</i> *	Asiatic bittersweet
<i>Centaurea maculosa</i> *	Knapweed
<i>Cerastium species</i> *	Moused-ear chickweeds
<i>Cercidiphyllum japonicum</i> *	Katsura
<i>Chelidonium majus</i> *	Greater celandine
<i>Chelone glabra</i>	Turtle-heads
<i>Chamaedaphne calyculata</i>	Leatherleaf
<i>Chimaphila maculata</i>	Spotted wintergreen
<i>Chimaphila umbellata</i>	Umbellate wintergreen
<i>Chrysosplenium americanum</i>	Golden saxifrage
<i>Cicuta species</i>	Water hemlocks
<i>Cinna latifolia</i>	Drooping wood reed

<i>Circaea alpina</i>	Dwarf enchanter's nightshade
<i>Circaea lutetiana</i>	Enchanter's nightshade
<i>Cirsium ?muticum</i>	Swamp thistle
<i>Clematis virginiana</i>	Virgin's-bower
<i>Clethra alnifolia</i>	Sweet pepper-bush
<i>Clinopodium vulgare</i> *	Wild basil
<i>Clintonia borealis</i>	Wood lily
<i>Collinsonia canadensis</i>	Canada horsebalm
<i>Comptonia peregrina</i>	Sweet-fern
<i>Conioselinum chinense</i>	Chinese hemlock-parsley
<i>Coptis trifolia</i>	Goldthread
<i>Corallorhiza trifida</i>	Yellow coralroot
<i>Cornus alternifolia</i>	Alternate-leaved dogwood
<i>Cornus amomum</i>	Silky dogwood
<i>Cornus canadensis</i>	Bunchberry
<i>Cornus rugosa</i>	Round-leaved dogwood
<i>Cornus stolonifera</i>	Red osier dogwood
<i>Corydalis sempervirens</i>	Rock harlequin
<i>Corylus cornuta</i>	Beaked hazel
<i>Crataegus brainerdii</i>	Hawthorn
<i>Cryptotaenia canadensis</i>	Honewort
<i>Cypripedium acaule</i>	Pink lady slipper
<i>Cystopteris bulbifera</i>	Bulblet bladderfern
<i>Cystopteris tenuis</i>	Upland brittle bladderfern
<i>Dactylis glomerata</i> *	Orchard grass
<i>Danthonia compressa</i>	Northern oat grass
<i>Danthonia spicata</i>	Poverty-grass
<i>Dasiphora fruticosa</i>	Shrubby cinquefoil
<i>Daucus carota</i> *	Queen Anne's-lace
<i>Decodon verticillatus</i>	Swamp loosestrife
<i>Dennstaedtia punctilobula</i>	Hay-scented fern
<i>Dentaria concatenata</i>	Cutleaf toothwort
<i>Deparia acrostichoides</i>	Silvery spleenwort
<i>Deschampsia flexuosa</i>	Wavy hairgrass
<i>Desmodium species</i>	Tick-clovers
<i>Dianthus armeria</i> *	Deptford pink
<i>Dicanthelium acuminatum</i> var. <i>implicatum</i>	Woolly panic grass
<i>Dicanthelium latifolium</i>	Broad-leaved rosette panic grass

<i>Dicanthelium linearifolium</i>	Linear-leaved rosette panic grass
<i>Dicanthelium oligosanthes</i>	Scribner's panic grass
<i>Dicanthelium ?spretum</i>	Hairy rosette panic grass
<i>Dicanthelium villosissimum</i>	White-haired panic grass
<i>Dicentra cucullaria</i>	Dutchman's breeches
<i>Diervilla lonicera</i>	Bush honeysuckle
<i>Digitalis ?lanata</i>	Woolly foxglove
<i>Drosera rotundifolia</i>	Round leaved sundew
<i>Dryopteris carthusiana</i>	Spinulose wood fern
<i>Dryopteris cristata</i>	Crested wood fern
<i>Dryopteris intermedia</i>	Common wood fern
<i>Dryopteris marginalis</i>	Marginal wood fern
<i>Dulichium arundinaceum</i>	Three-way sedge
<i>Eleocharis obtusa</i>	Blunt spike rush
<i>Eleocharis species</i>	Spike rushes
<i>Elymus hystrix</i>	Bottlebrush grass
<i>Elymus species</i>	Wild ryes
<i>Elymus trachycaulus</i>	Slender wheatgrass
<i>Epifagus virginiana</i>	Beech drops
<i>Epigaea repens</i>	Trailing arbutus
<i>Epilobium coloratum</i>	Purple-leaf willow-herb
<i>Epipactis helleborine</i> *	Helleborine
<i>Equisetum arvense</i>	Common horsetail
<i>Equisetum sylvaticum</i>	Woodland horsetail
<i>Equisetum variegatum</i>	Variiegated horsetail
<i>Erigeron annuus</i>	Daisy-fleabane
<i>Erigeron philadelphicus</i>	Philadelphia fleabane
<i>Erigeron pulchellus</i>	Robin's-plantain
<i>Eriophorum viridi-carinatum</i>	Thinleaf cottonsedge
<i>Eriophorum species</i>	Cottonsedges
<i>Erythronium americanum</i>	Trout lily
<i>Eupatorium perfoliatum</i>	Common boneset
<i>Eupatorium ?sessilifolium</i>	Upland boneset
<i>Eurybia divaricata</i>	White wood aster
<i>Eurybia macrophylla</i>	Big-leaved aster
<i>Euthamia graminifolia</i>	Flat-top goldenrod
<i>Eutrochium ?purpureum</i>	Sweet Joe-pie weed
<i>Fagus grandifolia</i>	American beech
<i>Festuca subverticillata</i>	Nodding fescue

<i>Fragaria virginiana</i>	Wild strawberry
<i>Fraxinus americana</i>	White ash
<i>Fraxinus nigra</i>	Black ash
<i>Galium aparine</i> *	Cleavers
<i>Galium mollugo</i> *	White bedstraw
<i>Galium ?lanceolatum</i>	Wild licorice
<i>Galium tinctorium</i>	Bedstraw
<i>Galium ?trifidum</i>	Three-petaled bedstraw
<i>Galium triflorum</i>	Fragrant bedstraw
<i>Gaultheria procumbens</i>	Wintergreen
<i>Gaultheria hispidula</i>	Creeping snowberry
<i>Gaylussacia baccata</i>	Black huckleberry
<i>Geranium maculatum</i>	Wild geranium
<i>Geranium robertianum</i>	Herb Robert
<i>Geum canadense</i>	White avens
<i>Geum rivale</i>	Water avens
<i>Glyceria canadensis</i>	Rattlesnake grass
<i>Glyceria ?grandis</i>	American mannagrass
<i>Glyceria melicaria</i>	Slender manna grass
<i>Glyceria striata</i>	Fowl manna grass
<i>Gnaphalium obtusifolium</i>	Sweet everlasting
<i>Gymnocarpium dryopteris</i>	Northern oak-fern
<i>Hackelia virginiana</i>	Stickseed
<i>Hamamelis virginiana</i>	Witch-hazel
<i>Hesperis matronalis</i> *	Dame's-rocket
<i>Hieracium paniculatum</i>	Hawkweed
<i>Heuchera americana</i>	American alumroot
<i>Holcus lanatus</i> *	Common velvetgrass
<i>Houstonia caerulea</i>	Bluets
<i>Hyperzia lucidula</i>	Shining clubmoss
<i>Hydrocotyle americana</i>	Pennywort
<i>Hypericum boreale</i>	Northern st. Johnswort
<i>Ilex verticillata</i>	Winterberry holly
<i>Impatiens capensis</i>	Spotted jewelweed
<i>Impatiens pallida</i>	Pale jewelweed
<i>?Inula helenium</i>	Elecampagne
<i>Iris versicolor</i>	Blue flag
<i>Juncus effusus</i>	Soft rush
<i>Juncus ?greenii</i>	Greene's rush

<i>Juncus pelocarpus</i>	Brown-fruited rush
<i>Juncus tenuis</i>	Slender yard-rush
<i>Kalmia angustifolia</i>	Sheep laurel
<i>Kalmia latifolia</i>	Mountain laurel
<i>Laportea canadensis</i>	Canadian wood nettle
<i>Larix laricina</i>	Eastern larch
<i>Ledum groenlandicum</i>	Bog Labrador tea
<i>Leersia oryzoides</i>	Rice cutgrass
<i>Leucanthemum vulgare</i> *	Ox-eye daisy
<i>Ligustrum species</i>	Privets
<i>Lilium ?superbum</i>	Turk's-cap lily
<i>Linaria vulgaris</i> *	Common toadflax
<i>Lindera benzoin</i>	Spicebush
<i>Liriodendron tulipifera</i>	Tulip tree
<i>Lobelia cardinalis</i>	Cardinal-flower
<i>Lobelia inflata</i>	Indian-tobacco
<i>Lobelia spicata</i>	Palespike lobelia
<i>Lonicera canadensis</i>	Fly honeysuckle
<i>Lonicera dioica</i>	Limber honeysuckle
<i>Lonicera morrowii</i> *	Morrow's honeysuckle
<i>Lotus corniculatus</i> *	Bird's-foot trefoil
<i>Ludwigia palustris</i>	Marsh seedbox
<i>Luzula acuminata</i>	Hairy woodrush
<i>Luzula campestris</i>	Common wood-rush
<i>Lychnis flos-cuculi</i> *	Ragged-robin
<i>Lycopodium annotinum</i>	Stiff clubmoss
<i>Lycopodium clavatum</i>	Wolf's-foot clubmoss
<i>Lycopodium obscurum</i>	Tree clubmoss
<i>Lycopus uniflorus</i>	Water-horehound
<i>Lycopus virginicus</i>	Water-horehound
<i>Lyonia ligustrina</i>	Maleberry
<i>Lysimachia ciliata</i>	Fringed loosestrife
<i>Lysimachia terrestris</i>	Earth loosestrife
<i>Lythrum salicaria</i> *	Purple loosestrife
<i>Maianthemum canadense</i>	False lily-of-the-valley
<i>Malus ?pumila</i> *	Common apple
<i>Matteuccia struthiopteris</i>	Ostrich fern
<i>Medeola virginiana</i>	Indian cucumber root
<i>Melampyrum lineare</i>	Narrowleaf cowwheat

<i>Melilotus alba</i> *	White sweet-clover
<i>Mentha arvensis</i>	Wild mint
<i>Mitchella repens</i>	Partridgeberry
<i>Mitella diphylla</i>	Miterwort
<i>Moehringia lateriflora</i>	Bluntleaf sandwort
<i>Monarda fistulosa</i>	Horsemint
<i>Monotropa hypopithys</i>	Dutchman's pipe
<i>Monotropa uniflora</i>	Indian-pipe
<i>Muhlenbergia species</i>	Wire stem muhly
<i>Nemopanthus mucronatus</i>	Mountain holly
<i>Nyssa sylvatica</i>	Black gum
<i>Oclemena acuminata</i>	Mountain aster
<i>Oenothera perennis</i>	Small sundrops
<i>Onoclea sensibilis</i>	Sensitive fern
<i>Oryzopsis asperifolia</i>	Roughleaf ricegrass
<i>Oryzopsis racemosa</i>	Black-seeded ricegrass
<i>Osmorhiza species</i>	Sweet cicilies
<i>Osmunda cinnamomea</i>	Cinnamon fern
<i>Osmunda claytoniana</i>	Interrupted fern
<i>Osmunda regalis</i>	Royal fern
<i>Ostrya virginiana</i>	Hop hornbeam
<i>Oxalis montana</i>	Mountain woodsorrel
<i>Oxalis ?stricta</i>	Lady's-sorrel
<i>Packera aurea</i>	Golden ragwort
<i>Packera obovata</i>	Golden groundsel
<i>Panax trifolius</i>	Dwarf ginseng
<i>Parnassia glauca</i>	American grass of Parnassus
<i>Paronychia canadensis</i>	Smooth forked nailwort
<i>Parthenocissus quinquefolia</i>	Virginia creeper
<i>Peltandra virginica</i>	Green arrow arum
<i>Penstemon species</i>	Beardtongues
<i>Phalaris arundinacea</i>	Reed canary-grass
<i>Phegopteris connectilis</i>	Long beechfern
<i>Phegopteris hexagonoptera</i>	Broad beech fern
<i>Phleum pratense</i> *	Timothy
<i>Phragmites australis</i> *	Common reed
<i>Phytolacca americana</i>	Pokeweed
<i>Picea rubens</i>	Red spruce
<i>Picea mariana</i>	Black spruce

<i>Pilea pumila</i>	Clearweed
<i>Pinus strobus</i>	White pine
<i>Plantago lanceolata</i> *	English plantain
<i>Plantago rugelii</i>	Pale plantain
<i>Platanus occidentalis</i>	Sycamore
<i>Platanthera clavellata</i>	Club-spur orchid
<i>Platanthera ?hyperborea</i>	Northern green orchid
<i>Platanthera species</i>	Butterfly orchids
<i>Poa alsodes</i>	Woodland bluegrass
<i>Poa annua</i> *	Annual bluegrass
<i>Poa compressa</i> *	Canada bluegrass
<i>Poa pratensis</i> *	Kentucky bluegrass
<i>Poa saltuensis</i>	Weak spear grass
<i>Poa trivialis</i> *	Rough bluegrass
<i>Podopyllum pedatum</i>	Mayapple
<i>Pogonia ophioglossoides</i>	Snakemouth orchid
<i>Polygala pauciflora</i>	Gaywings
<i>Polygonatum biflorum</i>	Small Solomon's-seal
<i>Polygonum arifolium</i>	Arrow leaf tear thumb
<i>Polygonum cespitosum</i> *	Low smartweed
<i>Polygonum cilinode</i>	Fringed black bindweed
<i>Polygonum sagittatum</i>	Tear thumb
<i>Polypodium appalachianum</i>	Appalachian polyploidy
<i>Polypodium virginianum</i>	Rock polyploidy
<i>Polystichum acrostichoides</i>	Hanukkah fern
<i>Populus deltoides</i>	Eastern Cottonwood
<i>Populus grandidentata</i>	Big tooth aspen
<i>Populus tremuloides</i>	Quaking aspen
<i>Potentilla canadensis</i>	Dwarf cinquefoil
<i>Potentilla simplex</i>	Common cinquefoil
<i>Prenanthes species</i>	Rattlesnake-root
<i>Primula ?japonica</i>	Japanese primrose
<i>Prunella vulgaris</i> *	Self-heal
<i>Prunus serotina</i>	Black cherry
<i>Prunus virginiana</i>	Choke cherry
<i>Pteridium aquilinum</i>	Bracken
<i>Pyrola rotundifolia</i>	Shinleaf
<i>Quercus alba</i>	White oak
<i>Quercus ?coccinea</i>	Scarlet oak

<i>Quercus montana</i>	Chestnut oak
<i>Quercus rubra</i>	Red oak
<i>Quercus velutina</i>	Black oak
<i>Ranunculus abortivus</i>	Kidney-leaf crowfoot
<i>Ranunculus hispidus</i>	Hispid buttercup
<i>Ranunculus recurvatus</i>	Blisterwort
<i>Rhamnus cathartica</i> *	Common buckthorn
<i>Rhododendron periclymenoides</i>	Pinkster-flower
<i>Rhododendron ?maximum</i>	Great laurel
<i>Rhododendron viscosum</i>	Swamp azalea
<i>Rhynchospora alba</i>	White beaksedge
<i>Ribes americanum</i>	American black currant
<i>Ribes glandulosum</i>	Skunk currant
<i>Ribes cynosbati</i>	Wild gooseberry
<i>Rosa multiflora</i> *	Multiflora rose
<i>Rosa ?virginiana</i>	Virginia rose
<i>Rubus allegheniensis</i>	Northern blackberry
<i>Rubus ?flagellaris</i>	Northern dewberry
<i>Rubus hispidus</i>	Swamp dewberry
<i>Rubus occidentalis</i>	Black raspberry
<i>Rubus odoratus</i>	Purple-flowering raspberry
<i>Rubus pubescens</i>	Dwarf raspberry
<i>Rudbeckia species</i> *	Black-eyed Susan
<i>Rumex acetosella</i> *	Sheep sorrel
<i>Sagittaria ?latifolia</i>	Broadleaf arrowhead
<i>Salix bebbii</i>	Bebb's willow
<i>Salix ?discolor</i>	Pussy willow
<i>Salix ?humilus</i>	Gray willow
<i>Salix ?nigra</i>	Black willow
<i>Salix sericea</i>	Silky willow
<i>Salix serissima</i>	Autumn willow
<i>Sambucus canadensis</i>	Black elderberry
<i>Sambucus racemosa ssp. pubens</i>	Red elderberry
<i>Sanguinaria canadensis</i>	Bloodroot
<i>Sanicula species</i>	Sanicles
<i>Sarracenia purpurea</i>	Northern pitcher plant
<i>Sassafras albidum</i>	Sassafras
<i>Saxifraga pensylvanica</i>	Swamp saxifrage
<i>Saxifraga virginiana</i>	Early saxifrage

<i>Schizachne purpurascens</i>	False melic
<i>Schizachyrium scoparium</i>	Little bluestem
<i>Schoenoplectus tabernaemontani</i>	Great bulrush
<i>Scirpus atrocinctus</i>	Black-girdled wooldsedge
<i>Scirpus cyperinus</i>	Wool grass
<i>Scirpus ?expansus</i>	Wood bulrush
<i>Scirpus hattorianus</i>	Dark green bulrush
<i>Scirpus ?microcarpus</i>	Panicled bulrush
<i>Scirpus pendulus</i>	Nodding bulrush
<i>Scrophularia lanceolata</i>	Hare-figwort
<i>Scutellaria galericulata</i>	Marsh skullcap
<i>Scutellaria lateriflora</i>	Common skullcap
<i>Sedum species</i> *	Stonecrops
<i>Selaginella apoda</i>	Meadow spikemoss
<i>Setaria pumila</i> *	Yellow foxtail
<i>Sisyrinchium montanum</i>	Blue-eyed grass
<i>Smilax herbacea</i>	Carrion-flower
<i>Solanum dulcamara</i> *	Climbing nightshade
<i>Solidago caesia</i>	Blue-stem goldenrod
<i>Solidago canadensis</i>	Canada goldenrod
<i>Solidago flexicaulis</i>	Zig-zag goldenrod
<i>Solidago juncea</i>	Early goldenrod
<i>Solidago nemoralis</i>	Gray goldenrod
<i>Solidago patula</i>	Spreading goldenrod
<i>Solidago rugosa</i>	Tall hairy goldenrod
<i>Solidago ?uliginosa</i>	Bog goldenrod
<i>Sonchus species</i> *	Sow thistles
<i>Sorbaria sorbifolia</i> *	False spirea
<i>Sorbus americana</i>	American mountain ash
<i>Sparganium species</i>	Bur-reeds
<i>Sphenopholis intermedia</i>	Slender wedge-grass
<i>Spiraea alba var. latifolia</i>	Meadow-sweet
<i>Spiraea tomentosa</i>	Steeplebush
<i>Stellaria graminea</i> *	Common stitchwort
<i>Stellaria species</i>	Chickweeds
<i>Streptopus roseus</i>	Rose twisted stalk
<i>Symphyotrichum lanceolatum</i>	Tall white aster
<i>Symphyotrichum lateriflorum</i>	Calico aster
<i>Symphyotrichum novae-angliae</i>	New England aster

<i>Symphytotrichum novi-belgii</i>	New York aster
<i>Symphytotrichum ?prenanthoides</i>	Crooked-stem aster
<i>Symphytotrichum puniceus</i>	Purple-stemmed aster
<i>Taraxacum officinale</i> *	Common dandelion
<i>Thalictrum dioicum</i>	Early meadow rue
<i>Thalictrum ?pubescens</i>	Tall meadow-rue
<i>Thalictrum thalictroides</i>	Rue anemone
<i>Thelypteris noveboracensis</i>	New York fern
<i>Thelypteris palustris</i>	Marsh fern
<i>Thelypteris simulata</i>	Bog fern
<i>Tiarella cordifolia</i>	Foamflower
<i>Tilia americana</i>	Basswood
<i>Torreychloa pallida</i> var. <i>pallida</i>	Pale manna grass
<i>Toxicodendron radicans</i>	Poison ivy
<i>Toxicodendron vernix</i>	Poison sumac
<i>Trientalis borealis</i>	Starflower
<i>Triadenum species</i>	St. Johns worts
<i>Trifolium repens</i> *	White clover
<i>Trillium erectum</i>	Purple trillium
<i>Trillium undulatum</i>	Painted trillium
<i>Tsuga canadensis</i>	Eastern Hemlock
<i>Tussilago farfara</i> *	Coltsfoot
<i>Typha latifolia</i>	Common cat-tail
<i>Ulmus americana</i>	American elm
<i>Urtica dioica</i> *	Stinging nettle
<i>Utricularia species</i>	Bladderworts
<i>Uvularia perfoliata</i>	Perfoliate bellwort
<i>Uvularia sessilifolia</i>	Sessile-leaved bellwort
<i>Vaccinium angustifolium</i>	Low bush blueberry
<i>Vaccinium corymbosum</i>	High bush blueberry
<i>Vaccinium ?oxycoccus</i>	Swamp cranberry
<i>Vaccinium stamineum</i>	Deerberry
<i>Valeriana officinalis</i> *	Valerian
<i>Veratrum viride</i>	False hellebore
<i>Verbena ?hastata</i>	Blue vervain
<i>Veronica americana</i>	American speedwell
<i>Veronica chamaedrys</i> *	Bird's-eye speedwell
<i>Veronica peregrina</i>	Purslane-speedwell
<i>Veronica officinalis</i> *	Speedwell

<i>Veronica serpyllifolia</i> *	Thyme-leaf speedwell
<i>Veronica scutellata</i>	Skullcap speedwell
<i>Viburnum acerifolium</i>	Maple-leaf viburnum
<i>Viburnum dentatum</i>	Southern arrow-wood
<i>Viburnum lantanoides</i>	Hobble-bush
<i>Viburnum lentago</i>	Nannyberry
<i>Viburnum opulus</i> var. <i>opulus</i>	Guelder-rose
<i>Viola blanda</i>	Sweet white violet
<i>Viola conspersa</i>	American dog-violet
<i>Viola cucullata</i>	Blue marsh violet
<i>Viola macloskeyi</i>	Pale violet
<i>Viola pubescens</i>	Downy yellow violet
<i>Viola rotundifolia</i>	Roundleaf yellow violet
<i>Viola sagittata</i>	Northern downy violet
<i>Viola sororia</i>	Common violet
<i>Vitis riparia</i>	Riverbank grape
<i>Vitis species</i>	Grape
<i>Woodsia ilvensis</i>	Rusty cliff fern
<i>Woodsia obtusa</i>	Bluntlobe cliff fern
<i>Zanthoxylum americanum</i>	Northern prickly-ash
<i>Zizia aurea</i>	Golden Alexanders

1 Nomenclature follows Flora North America Editorial Committee (1993+) and Mitchell and Tucker (1997)

(?) Denotes a tentative species identification

(\*) Denotes species regarded as alien to Connecticut (see Dowhan, 1979) or of doubtful native origin at this site

Wildlife Observed at Great Mountain Forest

## Mammals

- Opossum (*Didelphis virginiana*)
- Masked Shrew (*Sorex cinereus*)
- Water Shrew (*Sorex palustris*)
- Smoky Shrew (*Sorex fumeus*)
- Northern Short-tailed Shrew (*Blarina brevicauda*)
- Hairy-tailed Mole (*Parascalops breweri*)
- Eastern Mole (*Scalopus aquaticus*)
- Star-nosed Mole (*Condylura cristata*)
- Little Brown Bat (*Myotis lucifugus*)
- Northern Long Eared Bat (*Myotis septentrionalis*)
- Big Brown Bat (*Eptesicus fuscus*)
- Red Bat (*Lasiurus borealis*)
- Hoary Bat (*Lasiurus cinereus*)
- Silver-haired Bat (*Lasionycteris noctivagans*)
- Tri-colored Bat (formerly known as Eastern Pipistrelle) (*Pipistrellus subflavus*)
- Eastern Cottontail Rabbit (*Sylvilagus floridanus*)
- New England Cottontail Rabbit (*Sylvilagus transitionalis*)
- Snowshoe Hare (*Lepus americanus*)
- Eastern Chipmunk (*Tamias striatus*)
- Woodchuck (*Marmota monax*)
- Gray Squirrel (*Sciurus carolinensis*)
- Red Squirrel (*Tamiasciurus hudsonicus*)
- Southern Flying Squirrel (*Glaucomys volcans*)
- Northern Flying Squirrel (*Glaucomys sabrinus*)
- Beaver (*Castor canadensis*)
- Deer Mouse (*Peromyscus maniculatus*)
- Meadow Jumping Mouse (*Zapus hudsonius*)
- White-footed Mouse (*Peromyscus leucopus*)
- Southern Red-backed Vole (*Clethrionomys gapperi*)
- Meadow Vole (*Microtus pennsylvanicus*)
- Woodland Vole (*Microtus pinetorum*)
- Southern Bob Lemming (*Synaptomys cooperi*)
- Muskrat (*Ondatra zibethicus*)
- House Mouse (*Mus musculus*)
- Woodland Jumping Mouse (*Napaeozapus insignis*)
- Meadow jumping Mouse (*Zapus hudsonius*)
- Porcupine (*Erethizon dorsatum*)
- Coyote (*Canis latrans*)
- Red Fox (*Vulpes vulpes*)
- Gray Fox (*Urocyon cinereoargenteus*)
- Black Bear (*Ursus americanus*)

- Raccoon (*Procyon lotor*)
- Fisher (*Martes pennati*)
- Ermine (*Mustela erminea*)
- Long-tailed weasel (*Mustela frenata*)
- Mink (*Mustela vison*)
- Striped Skunk (*Mephitis mephitis*)
- River Otter (*Lontra canadensis*)
- Bobcat (*Lynx rufus*)
- White-tailed Deer (*Odocoileu virginianus*)
- Moose (*Alces alces*)

## Perching Birds

- Killdeer (*Rallus elegans*)
- Great Blue Heron (*Ardea herodias*)
- Mourning Dove (*Zenaidra macroura*)
- Common Nighthawk (*Chordeiles minor*)
- Chimney Swift (*Chaetura pelagica*)
- Ruby-throated Hummingbird (*Archilochus colubris*)
- Red-bellied woodpecker (*Melanerpes carolinus*)
- Yellow-bellied sapsucker (*Sphyrapicus varius*)
- Downy woodpecker (*Picoides pubescens*)
- Hairy woodpecker (*Picoides villosus*)
- Three-toed woodpecker (*Picoides tridactylus*)
- Northern flicker (*Colaptes auratus*)
- Pileated woodpecker (*Dryocopus pileatus*)
- Eastern phoebe (*Sayornis phoebe*)
- Eastern kingbird (*Tyrannus tyrannus*)
- Northern shrike (*Lanius excubitor*)
- Red-eyed vireo (*Vireo olivaceus*)
- Yellow-throated Vireo (*Vireo flavifrons*)
- Blue jay (*Cyanocitta cristata*)
- American crow (*Corvus brachyrhynchos*)
- Common raven (*Corvus corax*)
- Tree swallow (*Tachycineta bicolor*)
- Bank swallow (*Riparia riparia*)
- Barn swallow (*Hirundo rustica*)
- Black-capped chickadee (*Poecile hudsonicus*)
- Tufted titmouse (*Baeolophus bicolor*)
- Red-breasted nuthatch (*Sitta canadensis*)
- White-breasted nuthatch (*Sitta carolinensis*)
- Brown creeper (*Certhia americana*)
- House wren (*Troglodytes aedon*)

- Winter wren (*Troglodytes troglodytes*)
- Ruby-crowned kinglet (*Regulus calendula*)
- Blue-gray gnatcatcher (*Poliophtila carulea*)
- Eastern bluebird (*Sialia sialia*)
- Veery (*Catharus fuscescens*)
- Hermit thrush (*Catharus guttatus*)
- Wood thrush (*Hylocichla mustelina*)
- American robin (*Turdus migratorius*)
- Gray catbird (*Dumetella carolinensis*)
- Northern mockingbird (*Mimus polyglottos*)
- Brown thrasher (*Toxostoma rufum*)
- European starling (*Sturnus vulgaris*)
- Cedar waxwing (*Bombycilla cedrorum*)
- Chestnut-sided warbler (*Dendroica pensylvanica*)
- Magnolia warbler (*Dendroica magnolia*)
- Black-throated blue warbler (*Dendroica caerulescens*)
- Yellow-rumped warbler (*Dendroica coronata*)
- Black-throated green warbler (*Dendroica virens*)
- Blackburnian warbler (*Dendroica fusca*)
- Black and white warbler (*Mniotilta varia*)
- Chestnut-sided Warbler (*Setophaga pensylvanica*)
- Hooded Warbler (*Setophaga citrina*)
- American redstart (*Setophaga ruticilla*)
- Ovenbird (*Seiurus aucocephalus*)
- Scarlet tanager (*Piranga olivacea*)
- Eastern towhee (*Pipilo erythrophthalmus*)
- Chipping sparrow (*Spizella passerina*)
- Field sparrow (*Spizella pusilla*)
- Song Sparrow
- White-throated sparrow (*Zonotrichia albicollis*)
- Dark-eyed junco (*Junco hyemalis*)
- Snow bunting (*Plectrophenax nivalis*)
- Northern cardinal (*Cardinalis cardinalis*)
- Rose-breasted grosbeak (*Pheucticus ludovicianus*)
- Indigo bunting (*Passerina cyanea*)
- Bobolink (*Dolichonyx oryzivorus*)
- Red-winged blackbird (*Agelaius phoeniceus*)
- Common grackle (*Quiscalus quiscula*)
- Brown-headed cowbird (*Molothus ater*)
- Orchard oriole (*Icterus spurius*)
- Baltimore oriole (*Icterus galbula*)
- Pine grosbeak (*Pinicola enucleator*)

- Purple finch (*Carpodacus purpureus*)
- House finch (*Carpodacus mexicanus*)
- Red crossbill (*Loxia curvirostra*)
- American goldfinch (*Carduelis tristis*)
- Evening grosbeak (*Coccothraustes vespertinus*)
- House sparrow (*Passer domesticus*)
- Yellow-billed Cuckoo (*Coccyzus americanus*)
- Eastern Wood Pewee (*Contopus virens*)
- Eastern Kingbird (*Tyrannus tyrannus*)
- Brown-headed Cowbird (*Molothrus ater*)
- Golden-crowned Kinglet (*Regulus satrapa*)
- Blue-headed (Solitary) Vireo

## Waterfowl Observed at Great Mountain Forest

- Canada Goose (*Branta canadensis*)
- Snow Goose (*Chen caerulescens*)
- Brant (*Branta bernicla*)
- Wood Duck (*Aix sponsa*)
- American Black Duck (*Anas americana*)
- Mallard (*Anas platyrhynchos*)
- Blue-winged Teal (*Anas discors*)
- Green-winged Teal (*Anas crecca*)
- Ring-necked Duck (*Aythya collaris*)
- Bufflehead (*Bucephala albeola*)
- Common Goldeneye (*Bucephala clangula*)
- Hooded Merganser (*Lophodytes cucullatus*)
- Common Merganser (*Mergus merganser*)
- Red-breasted Merganser
- Common Loon (*Gavia immer*)
- Pied-billed Grebe (*Podilymbus podiceps*)

## Upland Game Birds Observed at Great Mountain Forest

- Ruffed Grouse (*Bonasa umbellus*)
- Wild Turkey (*Meleagris gallopavo*)
- American Woodcock (*Scolopax minor*)
- Common Snipe (*Gallinago gallinago*)

## Birds of Prey Observed at Great Mountain Forest

- Osprey (*Pandion haliaetus*)
- Bald Eagle (*Haliaeetus leucocephalus*)
- Sharp-shinned Hawk (*Accipiter striatus*)
- Cooper's Hawk (*Accipiter cooperii*)
- Northern Goshawk (*Accipiter gentilis*)
- Red-shouldered Hawk (*Buteo lineatus*)
- Broad-winged Hawk (*Buteo platypterus*)
- Red-tailed Hawk (*Buteo jamaicensis*)
- American Kestrel (*Falco sparverius*)
- Barn Owl (*Tyto alba*)
- Eastern Screech Owl (*Otus asio*)
- Great Horned Owl (*Bubo virginianus*)
- Snowy Owl (*Nyctea scandiaca*) W.W.J. & E.C.C.
- Barred Owl (*Strix varia*)
- Great Gray Owl (*Strix nebulosa*) D.F.R.
- Northern Saw-whet Owl (*Aegolius acadicus*)

## The Butterflies Observed at Great Mountain Forest (2004-2009)

### SWALLOWTAILS

- Black Swallowtail (*Papilio polyxenes*)
- Eastern Tiger Swallowtail (*Papilio glaucus*)
- Canadian Tiger Swallowtail (*Papilio canadensis*)
- Spicebush Swallowtail (*Papilio troilus*)

### WHITES & SULPHURS

- Cabbage White (*Pieris rapae*)
- Clouded Sulphur (*Colias philodice*)
- Orange Sulphur (*Colias eurytheme*)

### GOSSAMER-WINGS

- Banded Hairstreak (*Satyrium calanus*)
- Striped Hairstreak (*Satyrium liparops*)
- Eastern Tailed Blue (*Everes comyntas*)
- Summer Azure (*Celastrina neglecta*)

### BRUSH-FOOTS

- Great Spangled Fritillary (*Speyeria cybele*)
- Aphrodite Fritillary (*Speyeria aphrodite*)
- Silver-bordered Fritillary (*Boloria selene*)
- Meadow Fritillary (*Boloria bellona*)
- Pearl Crescent (*Phyciodes tharos*)
- Question Mark (*Polygonia interrogationis*)
- Eastern Comma (*Polygonia comma*)
- Compton Tortoiseshell (*Nymphalis vau-album*)
- Mourning Cloak (*Nymphalis antiopa*)
- American Lady (*Vanessa virginiensis*)
- Red Admiral (*Vanessa atalanta*)
- Red-spotted Purple (*Limenitis arthemis arthemis*)
- White Admiral (*Limenitis arthemis astyanax*)
- Northern Pearly Eye (*Enodia anthedon*)
- Appalachian Brown (*Satyrodes appalachia*)
- Little Wood-Satyr (*Megisto cymela*)
- Common Ringlet (*Coenonympha tullia*)
- Common Wood Nymph (*Cercyonis pegala*)
- Monarch (*Danaus plexippus*)

### SPREAD-WING SKIPPERS

- Silver-spotted Skipper (*Epargyreus clarus*)

### GRASS SKIPPERS

- Least Skipper (*Ancyloxypha numitor*)
- European Skipper (*Thymelicus lineola*)
- Indian Skipper (*Hesperia sassacus*)
- Peck's Skipper (*Polites peckius*)
- Tawny-edged Skipper (*Polites themistocles*)
- Long Dash (*Polites mystic*)
- Northern Broken Dash (*Wallengrenia egeremet*)
- Little Glassywing (*Pompeius verna*)
- Delaware Skipper (*Anatrytone logan*)
- Hobomok Skipper (*Poanes hobomok*)
- Zabulon Skipper (*Poanes zabulon*)
- Dun Skipper (*Euphyes vestris*)
- Pepper & Salt Skipper (*Amblyscirtes hegon*)





## ACKNOWLEDGMENTS

We are deeply indebted to the many wise friends who collaborated with us on this project. Dean Peter Crane initiated the project based on an idea from FES 2006 alum Dan Jones. We are grateful to both for your forward thinking and Dean Crane in particular for prioritizing this a worthwhile project. Mary Tyrrell managed the project and offered many useful insights and directives and we appreciate all her work.

Special thanks are due to the staff of Great Mountain Forest: We would like to acknowledge the tremendous assistance of GMF Director Hans Carlson, who offered his overwhelming support of this project, advice, useful information, and map-making skills to the final product; Jody Bronson for an excellent day in the field, access to over 30 years of detailed records, and sharing some of the best of GMF; Russell Russ for logistical help at Yale Camp and sharing good history. To Star Childs, with most of a lifetime at GMF, for sharing special places and important history. Thanks to Jean Bronson for offering helpful advice and encouragement as we figured out how to fit the story together.

We are indebted to Tom Wessels for joining us for two field days to work out some kinks on land use history and important landscape revelations. We are grateful to our families and the people close to us for letting us live as hermits in the forest of Northwest Connecticut for the summer of 2015. And finally, thanks to the land for revealing a small slice of its remarkable natural and cultural history so others can find their place in the world through its interwoven narratives.

